

Section B Overview

Section B – Hydraulic Cylinders

PL-2 SeriesPage 3

- Series Codes PL, PM, PE & PG
- Medium duty service with industrial tie rod construction
- Nominal pressure up to 1000 PSI depending on bore size
- Standard bore sizes 1" - 8"
- 14 standard mounting styles

PH-2 SeriesPage 49

- Series Codes PH, PJ, PF & PK
- Heavy duty service with industrial tie rod construction
- Nominal pressure up to 3000 PSI
- Standard bore sizes 1½" - 6"
- 16 standard mounting styles

PH-3 SeriesPage 79

- Series Codes PH, PJ, PF & PK
- Heavy duty service with industrial tie rod construction
- Nominal pressure up to 3000 PSI
- Standard bore sizes 7" & 8"
- 15 standard mounting styles

PH-3 Series Large BorePage 105

- Series Codes PH, PJ, PF & PK
- Heavy duty service with industrial tie rod construction
- Nominal pressure up to 3000 PSI
- Standard bore sizes 10" - 20"
- 13 standard mounting styles

PHX SeriesPage 123

- Series Code PHX
- Hydraulic & electrohydraulic actuators
- LDT & LRT feedback options
- Bolt-on & internal manifold options

SHM SeriesPage 127

- ISO 6020/2 mounting interchangeable with tie rod construction
- Nominal pressure up to 210 Bar (3000 PSI)
- Metric cylinders with bore sizes 25mm - 200mm
- 12 standard mounting styles

Series CHE/CHDPage 145

- Compact hydraulic cylinders
- Nominal pressure up to 140 Bar for CHE; up to 207 Bar for CHD
- Standard bore sizes 20mm - 100mm
- Magnetic piston & solid state/reed switch options

B

PL-2

PH-2

PH-3

PHX

SHM

CHE/CHD



PL-2 Series



PH-2 Series



Series SHM



Series CHE/CHD

Hydraulic Cylinders

PL-2, PH-2, PH-3, SHM and Series CHE/CHD Hydraulic Cylinders are designed to meet your application requirements – with quality and reliability at a price that won't stretch your budget.

Schrader cylinders perform like you expect – producing more power per pound, more power per dollar – through millions of trouble-free cycles. Everything you need for reliable 3,000 psi performance. Rod gland with polyurethane rod seal for longer life and lower operating costs. Chrome-plated case hardened piston rods. Rod end studs of high yield strength steel, with rolled threads for added strength. Tie rods with rolled threads and steel nuts. Floating cushions with float-check action and positive metal-to-metal seal. And every Schrader cylinder is individually tested before it leaves our plant.

J.I.T. Delivery

PL-2, PH-2, PH-3, SHM and CHE/CHD cylinders are available from your local Schrader Bellows distributor and are shipped from our strategically located regional manufacturing plants to save you freight costs and ensure J.I.T. delivery when you want it!

For more detailed information on our cylinder products and capabilities, check the yellow pages and call your local Schrader Bellows distributor. Or contact Schrader Bellows, 500 S. Wolf Road, Des Plaines, Illinois 60016. (847) 298-2400.

Schrader Bellows®

®Registered Trademark, Schrader Bellows



Contents

Features	4	Cylinder Accessories	40-43
Specifications / Mountings	5	"Style 6" Piston Rod End	44-45
Design Features and Benefits	6-7	How to Order	46-47
Mounting Information, 1" to 6" Bore Sizes	8-27	Linear Alignment Couplers	48
Mounting Information, 8" Bore Size	28-35	Parts I.D. and Seal Kits	Sec. C, pgs. 32-36
Spherical Bearing Mounting	36-38	Application Engineering Data	Sec. C, pgs. 49-85
Double Rod Models	39		

B

PL-2

PH-2

PH-3

PHX

SHM

CHE/CHD

Schrader Bellows PL-2 Series Medium Duty Hydraulic Cylinder



When the job calls for reliable performance, specify PL-2 Series. A 100,000 psi yield strength chrome-plated, case-hardened piston rod. A 125,000 psi yield strength rod-end stud with rolled threads. 100,000 psi yield strength tie rods. With construction like this, it's no wonder Schrader Bellows PL-2 Series are truly premium quality cylinders. And to make sure every cylinder is premium quality, we subject each and every one — not just batch samples — to tough inspection and performance tests. See the following pages for the inside story on all the features that make PL-2 Series the high performance, long lasting choice for your medium duty hydraulic applications.

Note: Rod Diameters over 2 $\frac{1}{2}$ " will use a threaded nose gland.

Standard Specifications

- Medium-Duty Service – ANSI/(NFPA) T3.6.7R2-1996 Specifications and Mounting Dimension Standards
- Standard Construction – Square Head – Tie Rod Design
- Nominal Pressure – 1000 PSI Dependent on Bore Size*
- Standard Fluid – Hydraulic Oil
- Standard Temperature – -10° F. to +165°F.**
- Bore Sizes – 1" through 8"
- Piston Rod Diameters – 1/2" through 5 1/2"

- Mounting Styles – 14 standard styles at various application ratings
- Strokes – Available in any practical stroke length
- Cushions – Optional at either end or both ends of stroke. Float Check at cap end.
- Rod Ends – Three Standard Choices – Specials to Order

* See Section C for recommended operating pressure.

** See Section C, "Operating Fluids and Temperature Range" for higher temperature service.

In line with our policy of continuing product improvement, specifications in this catalog are subject to change.

Mounting Styles and Ordering Notes

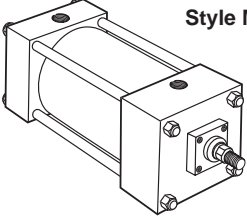
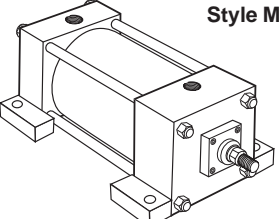
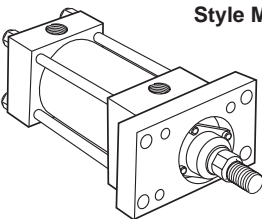
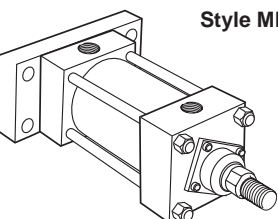
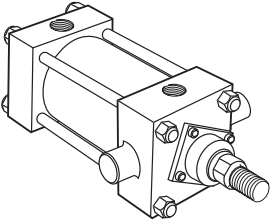
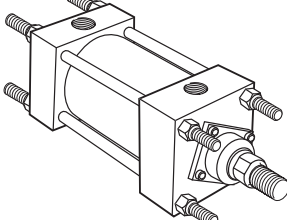
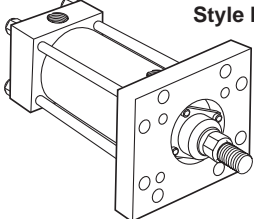
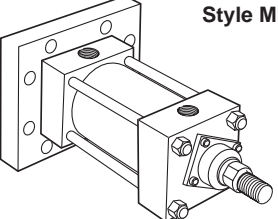
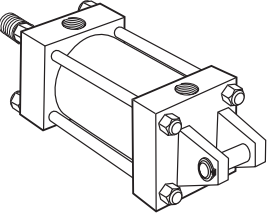
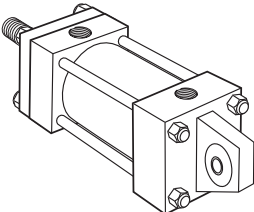
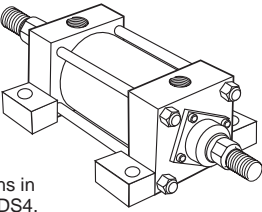
Available in all bore and rod combinations.		Available in all bore and rod combinations through 6" bore. 8" bores supplied as Head Square (ME3) and Cap Square (ME4) mounts.																																																																					
<p>Side Tap Style MS4</p> 	<p>Side Lug Style MS2</p> 	<p>Head Rectangular Flange Style MF1</p> 	<p>Cap Rectangular Flange Style MF2</p> 																																																																				
<p>Trunnion Mounts Head Style MT1 Cap Style MT2 Intermediate Fixed MT4</p> 		<p>Tie Rods Extended Both Ends MX1 Cap End MX2 Head End MX3</p> 		<p>Head Square Flange Style MF5</p> 	<p>Cap Square Flange Style MF6</p> 																																																																		
<p>Cap Fixed Clevis Style MP1</p>  <p>Pivot Pin Included</p>		<table border="1"> <thead> <tr> <th colspan="2">Rod Bearing Cartridges</th> <th>MX1 MX2 MS2 MF2 MT1 MPU3</th> <th>MX3 MS4 MF6 MT2 MT4 MP1</th> <th>MF1 MF5</th> <th>ME3 ME4</th> </tr> </thead> <tbody> <tr> <td>Bore</td> <td>Rod Dia.</td> <td></td> <td></td> <td></td> <td></td> </tr> <tr> <td>1</td> <td>1/2, 5/8</td> <td></td> <td>T</td> <td>T</td> <td>N/A</td> </tr> <tr> <td>1 1/2</td> <td>5/8 1</td> <td>R</td> <td>T</td> <td>T</td> <td>N/A</td> </tr> <tr> <td>2</td> <td>5/8 1 1 3/8</td> <td>R</td> <td>T</td> <td>T</td> <td>N/A</td> </tr> <tr> <td>2 1/2</td> <td>5/8 1 1 3/8 1 3/4</td> <td>R</td> <td>T</td> <td>T</td> <td>N/A</td> </tr> <tr> <td>3 1/4</td> <td>1 1 3/8 1 3/4, 2</td> <td>R</td> <td>R</td> <td>R</td> <td>N/A</td> </tr> <tr> <td>4</td> <td>1, 1 3/8 1 3/4, 2 2 1/2</td> <td>R</td> <td>R</td> <td>R</td> <td>N/A</td> </tr> <tr> <td>5</td> <td>1-2 2 1/2 3, 3 1/2</td> <td>R</td> <td>R</td> <td>T</td> <td>N/A</td> </tr> <tr> <td>6</td> <td>1 3/8-2 1/2 3-4</td> <td>R</td> <td>R</td> <td>T</td> <td>N/A</td> </tr> <tr> <td>8*</td> <td>1 3/8-4 1/2 5, 5 1/2</td> <td>R</td> <td>R</td> <td>N/A</td> <td>R</td> </tr> </tbody> </table> <p>R = Removable Cartridge T = Tie Rod Retained Cartridge</p> <p>* MF5, MF6, MF1 and MF2 not available in this bore size.</p>				Rod Bearing Cartridges		MX1 MX2 MS2 MF2 MT1 MPU3	MX3 MS4 MF6 MT2 MT4 MP1	MF1 MF5	ME3 ME4	Bore	Rod Dia.					1	1/2, 5/8		T	T	N/A	1 1/2	5/8 1	R	T	T	N/A	2	5/8 1 1 3/8	R	T	T	N/A	2 1/2	5/8 1 1 3/8 1 3/4	R	T	T	N/A	3 1/4	1 1 3/8 1 3/4, 2	R	R	R	N/A	4	1, 1 3/8 1 3/4, 2 2 1/2	R	R	R	N/A	5	1-2 2 1/2 3, 3 1/2	R	R	T	N/A	6	1 3/8-2 1/2 3-4	R	R	T	N/A	8*	1 3/8-4 1/2 5, 5 1/2	R	R	N/A	R
Rod Bearing Cartridges		MX1 MX2 MS2 MF2 MT1 MPU3	MX3 MS4 MF6 MT2 MT4 MP1	MF1 MF5	ME3 ME4																																																																		
Bore	Rod Dia.																																																																						
1	1/2, 5/8		T	T	N/A																																																																		
1 1/2	5/8 1	R	T	T	N/A																																																																		
2	5/8 1 1 3/8	R	T	T	N/A																																																																		
2 1/2	5/8 1 1 3/8 1 3/4	R	T	T	N/A																																																																		
3 1/4	1 1 3/8 1 3/4, 2	R	R	R	N/A																																																																		
4	1, 1 3/8 1 3/4, 2 2 1/2	R	R	R	N/A																																																																		
5	1-2 2 1/2 3, 3 1/2	R	R	T	N/A																																																																		
6	1 3/8-2 1/2 3-4	R	R	T	N/A																																																																		
8*	1 3/8-4 1/2 5, 5 1/2	R	R	N/A	R																																																																		
<p>Spherical Bearing Style MPU3</p> 		<p>Double End Construction</p>  <p>Available in all bore and rod combinations in the following mounting styles: MDS2, MDS4, MDX1, MDX3, MDT1, MDT4, and MDF1 (1"-6"). MDF5 (1"-6") and MDE3 (8").</p>																																																																					

The inside story... Why PL-2 Series is your best choice in medium-duty hydraulic cylinders.

Primary Seal – “Tuffseal” Special polyurethane seal is a proven leakproof design, which incorporates the pressure-compensated uni-directional characteristics of a “U CUP” with the multiple edge sealing effectiveness of compression-type stacked-packings.

Secondary Seal – A Double-Service Wiperseal™ acts as a secondary pressure seal on the extend stroke and cleans the rod on the return stroke.

Bolt-On Rod Cartridge – Assures true concentricity and allows removal without tie rod disassembly.

Piston Rod Stud – Furnished on 2" diameter rods and smaller when standard style #2 rod end threads are required. Piston rod studs are also available in 2 times the catalog “A” dimension length. Studs have rolled threads and are made from high strength steel. Anaerobic adhesive is used to permanently lock the stud to the piston rod.

Long Bearing Surface – is inboard of the seals, assuring positive lubrication from within the cylinder. An “O” ring is used as a seal between gland and head, and also serves as a prevailing torque-type lock.

Steel Head – Bored and grooved to provide concentricity for mating parts.

Ports – NPTF ports are standard. SAE ports available.

End Seals – Pressure-actuated cylinder body-to-head and cap O rings.

Alloy Steel Tie Rod Nuts

Align-A-Groove – A $\frac{3}{16}$ " wide surface machined at each end of the cylinder body. This makes precise mounting quick and easy.

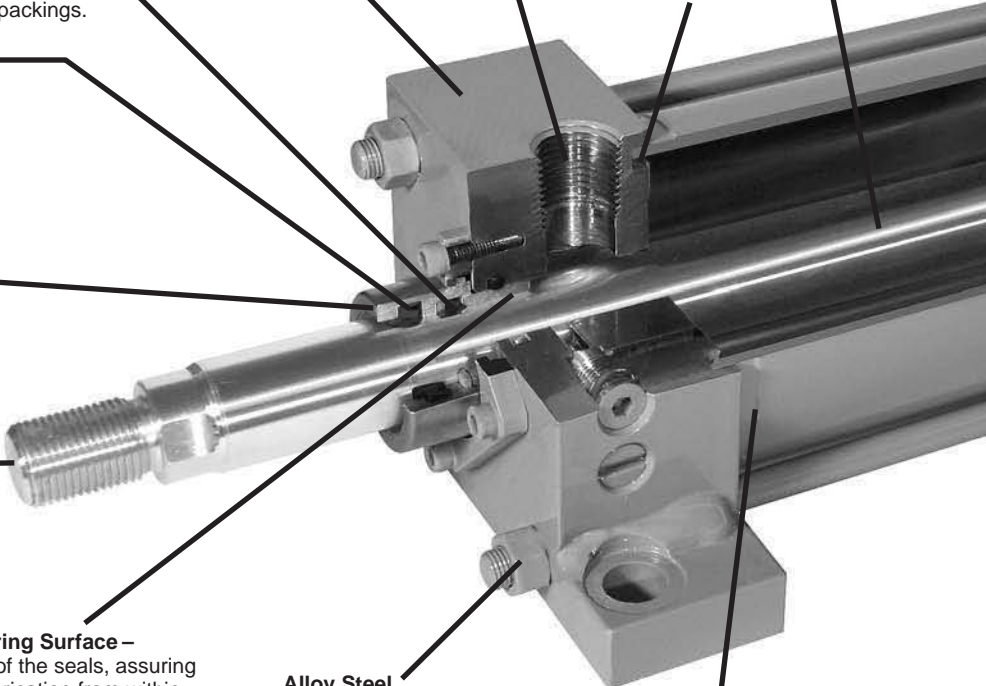

Adjustable floating cushions

Cushions are optional, and can be supplied at head end, cap end, or both ends without change in envelope or mounting dimensions. Cushions are adjustable.

The PL-2 Series cylinder design incorporates the longest cushion sleeve and cushion spear that can be provided in the standard envelope without decreasing the rod bearing and piston bearing lengths.

- (1) When a cushion is specified at the head end:
 - a. A self-centering sleeve is supplied on the piston rod assembly.
 - b. A needle valve is provided that is flush with the side of the head when wide open. It may be identified by the fact that it is socket-keyed. Needle valves are located on side number 2 in all mounting styles except MT1, MT2 and MT4. These styles have needle valves located on side number 3.
 - c. On $3\frac{1}{4}$ " bores and larger, a springless check valve is provided that is also flush with the side of the head and is mounted on the face adjacent

to the needle valve except on certain bores of mounting style MS2 where it is mounted opposite the needle valve. It may be identified by the fact that it is slotted.

- d. The check and needle valves are interchangeable in the head.
- e. 1" to $2\frac{1}{2}$ " bore PL-2 series utilize a slotted sleeve design in place of the check valve.
- (2) When a cushion is specified at the cap end:
 - a. A cushion spear is provided on the piston rod assembly.
 - b. A “Float Check” self-centering bushing is provided which incorporates a large flow check valve for fast “out-stroke” action.
 - c. A socket-keyed needle valve is provided that is flush with the side of the cap when wide open. It is located on side number 2 in all mounting styles except MT1, MT2 and MT4. These styles have needle valves located on side number 3.

Adjustable Floating Cushions – Cushions are optional and can be supplied at head end, cap end, or both ends without change in envelope or mounting dimensions.

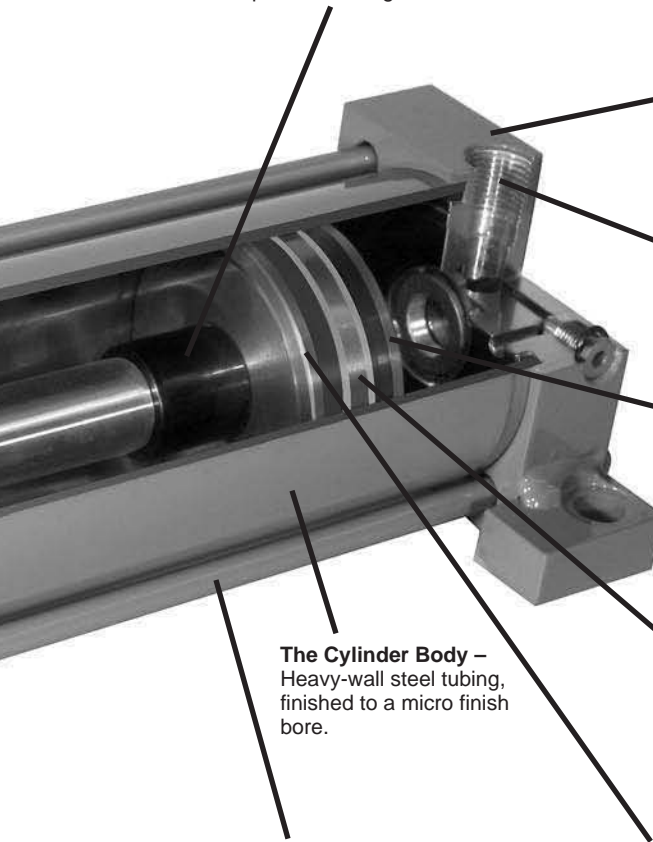

Steel Cap – Bored and grooved to provide concentricity for mating parts.

Ports – NPTF ports are standard. SAE ports available.

Piston Lipseal – Zero leakage under static conditions. Seals are self-compensating to conform to variations in pressure, mechanical deflection, and wear. Backup washers prevent extrusion.

Wear bands are furnished standard on cylinder bores 8" and larger to ensure long service life.

The Cylinder Body – Heavy-wall steel tubing, finished to a micro finish bore.

High Strength Tie Rods – Made from 100,000 psi minimum yield steel with rolled threads for added strength.

One-Piece Nodular Iron Piston – The wide piston surface contacting cylinder bore reduces bearing loads. Anaerobic adhesive is used to permanently lock and seal the piston to the rod.

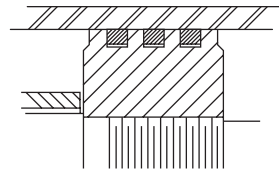

Step Cut Iron Piston Rings are optional.

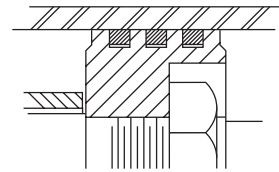

Piston with Retainer Nut – optional at extra charge.

Note: Threaded Rod Glands are supplied on cylinders with rod diameters over 2 1/2".

Sleeve Design | Spear Design

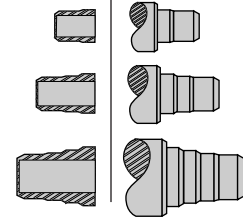

Cushion Length

Cylinder Bore (Inches)	Rod Diameter* (Inches)	Cushion Length (Inches)	
		Head*	Cap
1	1/2	7/8	3/4
	5/8	7/8	3/4
1 1/2	5/8	7/8	13/16
	1	7/8	13/16
2	5/8	7/8	13/16
	1 3/8	7/8	13/16
2 1/2	1	7/8	13/16
	1 3/4	7/8	13/16
3 1/4	1	1 1/8	1
	2	13/16	1
4	1 3/8	1 1/8	1
	2 1/2	13/16	1

Cylinder Bore (Inches)	Rod Diameter* (Inches)	Cushion Length (Inches)	
		Head*	Cap
5	1 3/4	1 1/8	1
	3 1/2	13/16	1
6	1 3/4	1 3/8	1 1/4
	4	1 1/16	1 1/4
8	2	1 1/16	1 1/4
	5 1/2	15/16	1 1/4

*Head end cushion for rod diameters not listed have cushion lengths within the limits shown.

Side Lug Mount

Style MS2

1" - 1 1/2" - 2" - 2 1/2" - 5" and 6"

Bore With Maximum Oversize Rods

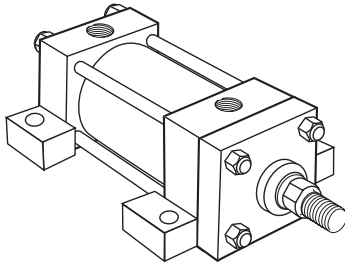

Tie Rod Retained Cartridge

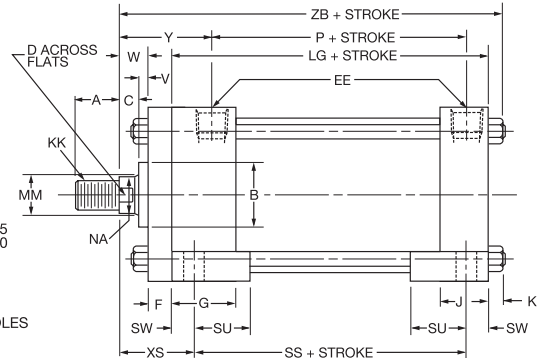
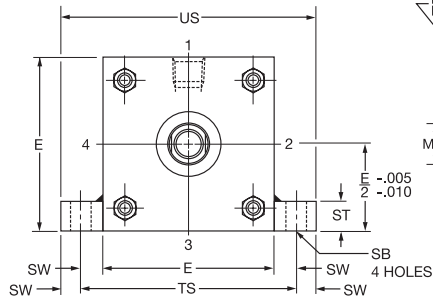

Before determining dimensions: See rod bearing cartridges chart on specifications/mountings page for cylinder rod combinations that have removable cartridges.

Side Lug Mount

Style MS2

1 1/2" - 6" Bore

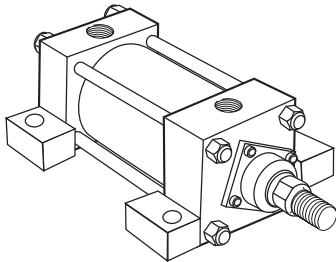

Removable Cartridge

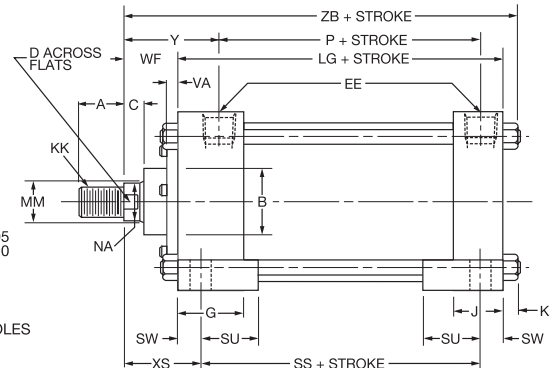
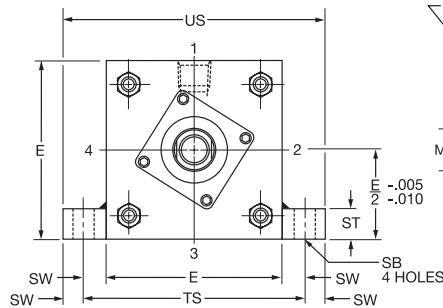

Rod End Dimensions — see table 2

Thread Style 2

Small Male

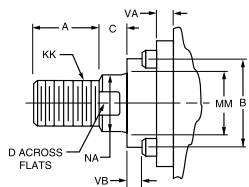

Thread Style 3

Short Female

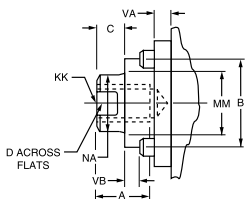

Thread Style 4

Intermediate Male

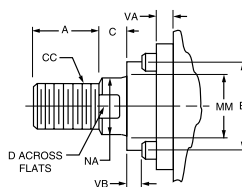

"Special" Thread Style 0

Special thread, extension, rod eye, blank, etc., are also available.

To order, specify "Style 0" and give desired dimensions for KK, A, W or WF. If otherwise special, furnish dimensioned sketch.

Straight Thread Port Adapters

Used on 1 1/2" bore size only.

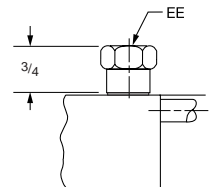

A high strength rod end stud is supplied on thread style 2 through 2" diameter rods. Larger sizes or special rod ends are cut threads. Style 2 rod ends are recommended where the workpiece is secured against the rod shoulder. When the workpiece is not shouldered, style 2 rod ends are recommended

through 2" piston rod diameters and style 4 rod ends are recommended on larger diameters. Use style 3 for applications where female rod end threads are required. If rod end is not specified, style 2 will be supplied.

Table 1—Envelope and Mounting Dimensions

Bore	E	EE		F	G	J	K	SB*	ST	SU	SW	TS	US	Add Stroke		
		NPTF [†]	SAE*											LG	P	SS
1"	■	1/4	6	3/8	1 1/2	1	3/16	9/32	5/16	3/4	5/16	2 1/8	2 3/4	3 1/2	2 1/8	2 7/8
1 1/2"	2	3/8†	6#	3/8	1 1/2	1	1/4	7/16	1/2	15/16	3/8	2 3/4	3 1/2	3 5/8	2 1/4	2 7/8
2"	2 1/2	3/8†	6	3/8	1 1/2	1	5/16	7/16	1/2	15/16	3/8	3 1/4	4	3 5/8	2 1/4	2 7/8
2 1/2"	3	3/8†	6	3/8	1 1/2	1	5/16	7/16	1/2	15/16	3/8	3 3/4	4 1/2	3 3/4	2 3/8	3
3 1/4"	3 3/4	1/2	10	—	1 3/4	1 1/4	3/8	9/16	3/4	1 1/4	1/2	4 3/4	5 3/4	4 1/4	2 5/8	3 1/4
4"	4 1/2	1/2	10	—	1 3/4	1 1/4	3/8	9/16	3/4	1 1/4	1/2	5 1/2	6 1/2	4 1/4	2 5/8	3 1/4
5"	5 1/2	1/2	10	5/8	1 3/4	1 1/4	7/16	13/16	1	1 9/16	11/16	6 7/8	8 1/4	4 1/2	2 7/8	3 1/8
6"	6 1/2	3/4	12	3/4	2	1 1/2	7/16	13/16	1	1 9/16	11/16	7 7/8	9 1/4	5	3 1/8	3 5/8

⊖ NPTF ports will be furnished as standard unless SAE straight thread ports are specified.

* SAE straight thread ports are indicated by port number.

■ 1" bore head is 1 3/4" x 1 1/2". See mounting style MF1 page.

† On 1 1/2", 2" and 2 1/2" bore sizes the head end (only) pipe thread is not full depth on cylinders with maximum oversize rods. Minimum of 3 full threads available.

Straight thread ports. On 1 1/2" bore size an adapter fitting is required on cap end and on head end with maximum oversize rod. (See "Straight Thread Port Adapter" drawing.) Adapters are furnished as standard.

• Upper surface spotfaced for socket head screws.

‡ Cushion adjusting needle valve for 1" bore projects beyond sides of head and cap.

Table 2—Rod End Dimensions and Envelope Dimensions Affected by Rod Size

Bore	Rod Dia. MM	Thread		Rod End Dimensions and Envelope Dimensions Affected by Rod Size												Add Stroke ZB
		Style 4 CC	Style 2 & 3 KK	A	+0.000 -0.002 B	C	D	NA	V	VA	VB	W	WF	XS	Y	
																Add Stroke
1	1/2	7/16-20	5/16-24	5/8	.999	3/8	3/8	7/16	1/4	—	—	5/8	—	1 5/16	1 15/16	4 11/16
	5/8	1/2-20	7/16-20	3/4	1.124	3/8	1/2	9/16	1/4	—	—	5/8	—	1 5/16	1 15/16	4 11/16
1 1/2	5/8	1/2-20	7/16-20	3/4	1.124	3/8	1/2	9/16	—	1/4	3/16	—	1	1 3/8	1 15/16	4 7/8
	1	7/8-14	3/4-16	1 1/8	1.499	1/2	7/8	1 5/16	1/2	—	—	1	—	1 3/4	2 5/16	5 1/4
2	5/8	1/2-20	7/16-20	3/4	1.124	3/8	1/2	9/16	—	1/4	3/16	—	1	1 3/8	1 15/16	4 15/16
	1 3/8	1 1/4-12	1-14	1 5/8	1.999	5/8	1 1/8	1 5/16	5/8	—	—	1 1/4	—	2	2 9/16	5 9/16
2 1/2	1	7/8-14	3/4-16	1 1/8	1.499	1/2	7/8	1 5/16	—	1/4	3/8	—	1 3/8	1 3/4	2 5/16	5 1/16
	1 3/4	1 1/2-12	1 1/4-12	2	2.374	3/4	1 1/2	1 11/16	3/4	—	—	1 1/2	—	2 1/4	2 13/16	5 5/16
3 1/4	1 3/8	1 1/4-12	1-14	1 5/8	1.999	5/8	1 1/8	1 5/16	5/8	—	—	1 1/4	—	2	2 9/16	5 11/16
	1 3/4	1 1/2-12	1 1/4-12	2	2.374	3/4	1 1/2	1 11/16	—	1/4	9/16	—	1 7/8	2 3/8	2 15/16	5 1/16
4	1 3/8	1 1/4-12	1-14	1 5/8	1.999	5/8	1 1/8	1 5/16	—	1/4	1/2	—	1 5/8	2 1/8	2 11/16	6 1/4
	2 1/2	2 1/4-12	1 7/8-12	3	3.124	1	2 1/16	2 3/8	—	1/4	1 1/16	—	2 1/4	2 3/4	3 5/16	6 7/8
5	1 3/4	1 1/2-12	1 1/4-12	2	2.374	3/4	1 1/2	1 11/16	—	1/4	9/16	—	1 7/8	2 3/8	2 15/16	6 1/2
	2	1 3/4-12	1 1/2-12	2 1/4	2.624	7/8	1 11/16	1 15/16	—	1/4	9/16	—	2	2 1/2	3 1/16	6 5/8
6	1	7/8-14	3/4-16	1 1/8	1.499	1/2	7/8	1 5/16	—	1/4	3/8	—	1 3/8	1 7/8	2 7/16	6
	1 3/4	1 1/2-12	1 1/4-12	2	2.374	3/4	1 1/2	1 11/16	—	1/4	9/16	—	1 7/8	2 9/16	2 15/16	6 13/16
3 1/4	3 1/2	3 1/4-12	2 1/2-12	3 1/2	4.249	1	3	3 3/8	5/8	—	—	1 5/8	—	2 15/16	3 5/16	7 3/16
	2	1 3/4-12	1 1/2-12	2 1/4	2.624	7/8	1 11/16	1 15/16	—	1/4	9/16	—	2	2 11/16	3 1/16	6 15/16
4	2 1/2	2 1/4-12	1 7/8-12	3	3.124	1	2 1/16	2 3/8	—	1/4	1 1/16	—	2 1/4	2 15/16	3 5/16	7 3/16
	3	2 3/4-12	2 1/4-12	3 1/2	3.749	1	2 5/8	2 7/8	5/8	—	—	1 5/8	—	2 15/16	3 5/16	7 3/16
5	1	7/8-14	3/4-16	1 1/8	1.499	1/2	7/8	1 5/16	—	1/4	3/8	—	1 3/8	2 1/16	2 7/16	6 5/16
	1 3/8	1 1/4-12	1-14	1 5/8	1.999	5/8	1 1/8	1 5/16	—	1/4	1/2	—	1 5/8	2 5/16	2 11/16	6 9/16
6	1 3/4	1 1/2-12	1 1/4-12	2	2.374	3/4	1 1/2	1 11/16	—	1/4	9/16	—	1 7/8	2 9/16	3 1/16	7 5/16
	4	3 3/4-12	3-12	4	4.749	1	3 3/8	3 7/8	1/2	—	—	1 1/2	—	2 15/16	3 7/16	7 11/16
3 1/4	2	1 3/4-12	1 1/2-12	2 1/4	2.624	7/8	1 11/16	1 15/16	—	1/4	9/16	—	2	2 11/16	3 3/16	7 7/16
	2 1/2	2 1/4-12	1 7/8-12	3	3.124	1	2 1/16	2 3/8	—	1/4	1 1/16	—	2 1/4	2 15/16	3 7/16	7 11/16
4	3	2 3/4-12	2 1/4-12	3 1/2	3.749	1	2 5/8	2 7/8	1/2	—	—	1 1/2	—	2 15/16	3 7/16	7 11/16
	3 1/2	3 1/4-12	2 1/2-12	3 1/2	4.249	1	3	3 3/8	1/2	—	—	1 1/2	—	2 15/16	3 7/16	7 11/16
5	1 3/8	1 1/4-12	1-14	1 5/8	1.999	5/8	1 1/8	1 5/16	—	1/4	7/16	—	1 5/8	2 5/16	2 13/16	7 1/16

Side Tap Mount

Style MS4

1 - 1 1/2" - 2" - 2 1/2" - 5"

and 6" Bore

With Maximum Oversize Rods

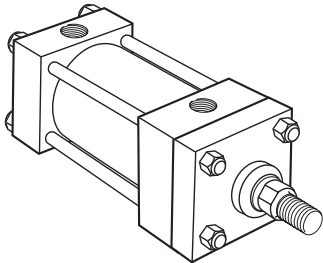

Tie Rod Retained Cartridge

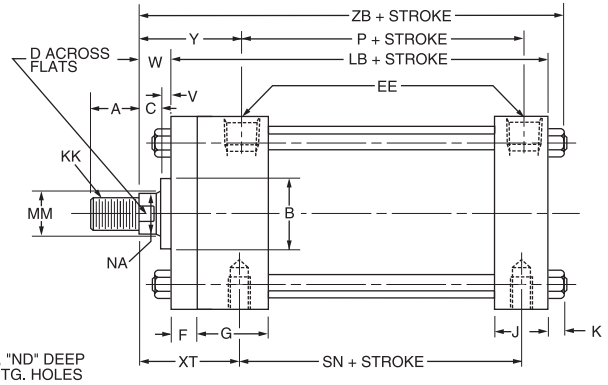
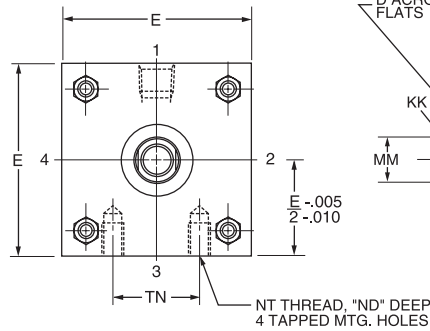

Before determining dimensions: See rod bearing cartridges chart on specifications/mountings page for cylinder rod combinations that have removable cartridges.

Side Tap Mount

Style MS4

1 1/2" - 6" Bore

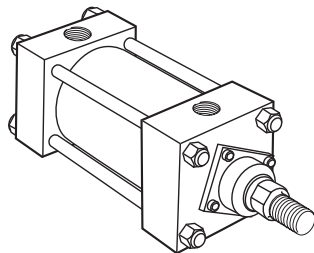

Removable Cartridge

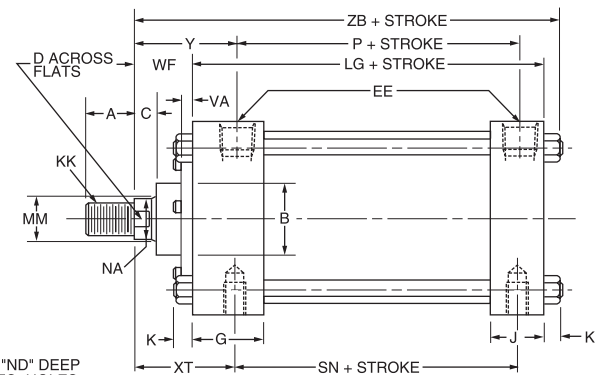
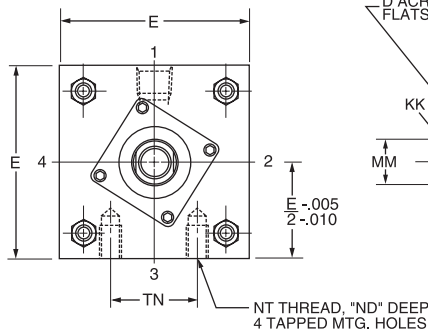

Rod End Dimensions — see table 2

Thread Style 2

Small Male

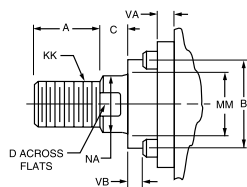

Thread Style 3

Short Female

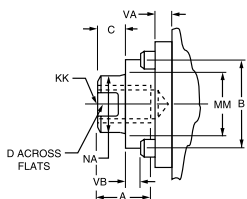

Thread Style 4

Intermediate Male

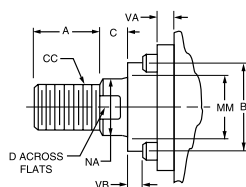

"Special" Thread Style 0

Special thread, extension, rod eye, blank, etc., are also available.

To order, specify "Style 0" and give desired dimensions for KK, A, W or WF. If otherwise special, furnish dimensioned sketch.

Straight Thread Port Adapters

Used on 1 1/2" bore size only.

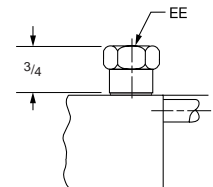

A high strength rod end stud is supplied on thread style 2 through 2" diameter rods. Larger sizes or special rod ends are cut threads. Style 2 rod ends are recommended where the workpiece is secured against the rod shoulder. When the workpiece is not shouldered, style 2 rod ends are recommended

through 2" piston rod diameters and style 4 rod ends are recommended on larger diameters. Use style 3 for applications where female rod end threads are required. If rod end is not specified, style 2 will be supplied.

Head Rectangular Flange Mount

Style MF1
1" - 6" Bore

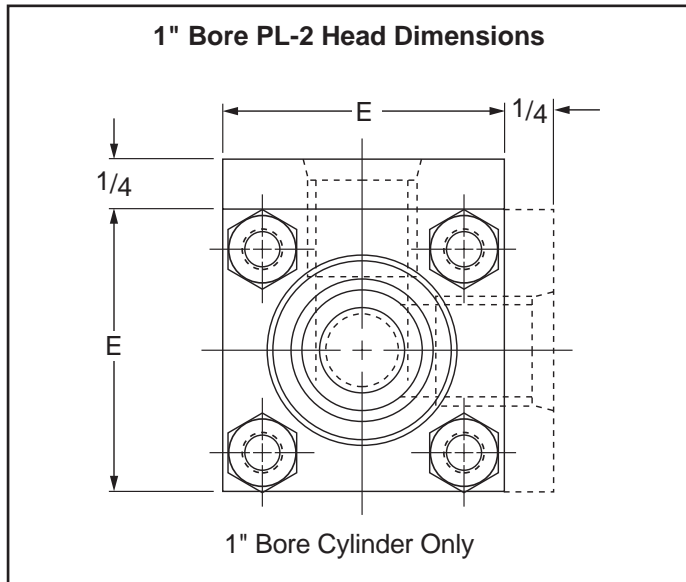
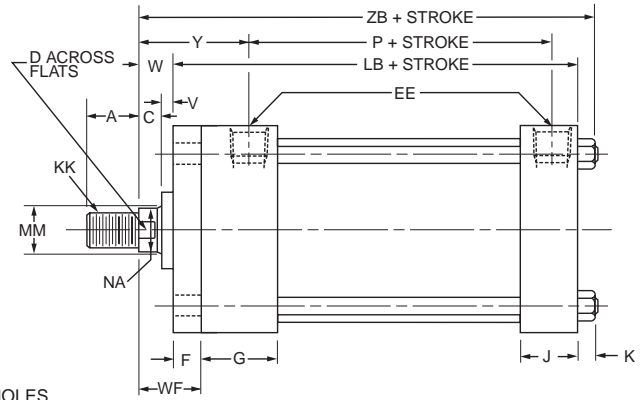
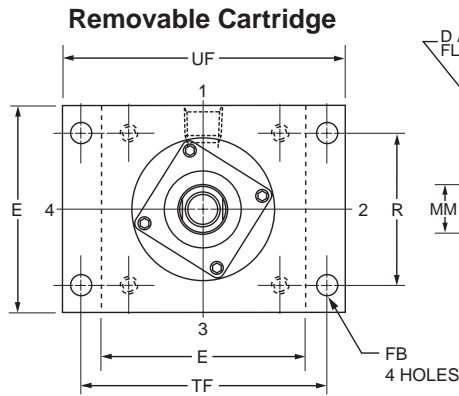
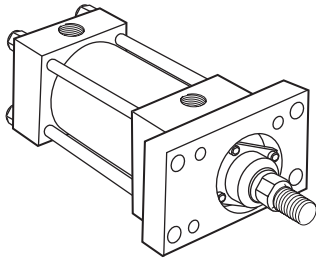

Maximum Pressure Ratings
Push Application (MF1 Model only)

Bore Dia.	Rod Dia.	PSI	Bore Dia.	Rod Dia.	PSI
1	1/2	1900	4	1	900
	5/8	1500		1 3/8	750
1 1/2	5/8	1200		1 3/4	500
	1	700		2	500
2	5/8	450	5	2 1/2	600
	1	700		1	600
2 1/2	1 3/8	400		1 3/8	600
	5/8	500	1 3/4	500	
	1	300	2	450	
	1 3/8	500	2 1/2	600	
3 1/4	1 3/4	300	6	3	450
	1	1000		3 1/2	400
	1 3/8	650		1 3/8	700
	1 3/4	1000		1 3/4	700
	2	800	2	700	
			2 1/2	600	
			3	600	
			3 1/2	600	
			4	450	

Rod End Dimensions — see table 2

Thread Style 2
Small Male

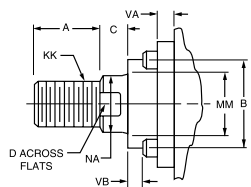

Thread Style 3
Short Female

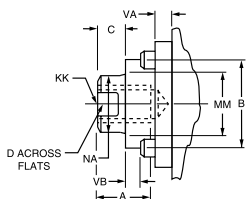

Thread Style 4
Intermediate Male

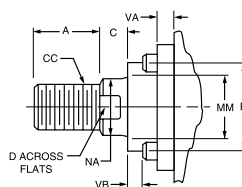

“Special”
Thread Style 0

Special thread, extension, rod eye, blank, etc., are also available.

To order, specify “Style 0” and give desired dimensions for KK, A, W or WF. If otherwise special, furnish dimensioned sketch.

Straight Thread
Port Adapters

Used on 1 1/2" bore size only.

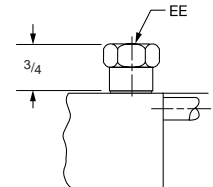

A high strength rod end stud is supplied on thread style 2 through 2" diameter rods. Larger sizes or special rod ends are cut threads. Style 2 rod ends are recommended where the workpiece is secured against the rod shoulder. When the workpiece is not shouldered, style 2 rod ends are recommended

through 2" piston rod diameters and style 4 rod ends are recommended on larger diameters. Use style 3 for applications where female rod end threads are required. If rod end is not specified, style 2 will be supplied.

Table 1—Envelope and Mounting Dimensions

Bore	E	EE		F	FB	G	J	K	R	TF	UF	Add Stroke	
		NPTF [⊖]	SAE*									LB	P
1 [†]	■	1/4	6	3/8	1/4	1 1/2	1	3/16	1.08	2	2 1/2	3 7/8	2 1/8
1 1/2	2	3/8 [†]	6 [#]	3/8	5/16	1 1/2	1	1/4	1.43	2 3/4	3 3/8	4	2 1/4
2	2 1/2	3/8 [†]	6	3/8	3/8	1 1/2	1	5/16	1.84	3 3/8	4 1/8	4	2 1/4
2 1/2	3	3/8 [†]	6	3/8	3/8	1 1/2	1	5/16	2.19	3 7/8	4 5/8	4 1/8	2 3/8
3 1/4	3 3/4	1/2	10	5/8	7/16	1 3/4	1 1/4	3/8	2.76	4 11/16	5 1/2	4 7/8	2 5/8
4	4 1/2	1/2	10	5/8	7/16	1 3/4	1 1/4	3/8	3.32	5 7/16	6 1/4	4 7/8	2 5/8
5	5 1/2	1/2	10	5/8	9/16	1 3/4	1 1/4	7/16	4.10	6 5/8	7 5/8	5 1/8	2 7/8
6	6 1/2	3/4	12	3/4	9/16	2	1 1/2	7/16	4.88	7 5/8	8 5/8	5 3/4	3 1/8

⊖ NPTF ports will be furnished as standard unless SAE straight thread ports are specified.

* SAE straight thread ports are indicated by port number.

‡ Cushion adjusting needle valve for 1" bore projects beyond sides of head and cap.

■ 1" bore head is 1 3/4" x 1 1/2". See previous page.

† On 1 1/2", 2" and 2 1/2" bore sizes the head end (only) pipe thread is not full depth on cylinders with maximum oversize rods. Minimum of 3 full threads available.

Straight thread ports. On 1 1/2" bore size an adapter fitting is required on cap end and on head end with maximum oversize rod. (See "Straight Thread Port Adapter" drawing.) Adapters are furnished as standard.

Table 2—Rod End Dimensions and Envelope Dimensions Affected by Rod Size

Bore	Rod Dia. MM	Thread		Rod Extensions and Envelope Dimensions Affected by Rod Size										Add Stroke
		Style 4 CC	Style 2 & 3 KK	A	+0.000 -0.002 B	C	D	NA	V	W	WF	Y	ZB	
		1	1/2	7/16-20	5/16-24	5/8	.999	3/8	3/8	7/16	1/4	5/8	1	1 15/16
	5/8	1/2-20	7/16-20	3/4	1.124	3/8	1/2	9/16	1/4	5/8	1	1 15/16	4 11/16	
1 1/2	5/8	1/2-20	7/16-20	3/4	1.124	3/8	1/2	9/16	1/4	5/8	1	1 15/16	4 7/8	
	1	7/8-14	3/4-16	1 1/8	1.499	1/2	7/8	1 5/16	1/2	1	1 3/8	2 5/16	5 1/4	
2	5/8	1/2-20	7/16-20	3/4	1.124	3/8	1/2	9/16	1/4	5/8	1	1 15/16	4 15/16	
	1 3/8	1 1/4-12	1-14	1 5/8	1.999	5/8	1 1/8	1 5/16	5/8	1 1/4	1 5/8	2 9/16	5 9/16	
	1	7/8-14	3/4-16	1 1/8	1.499	1/2	7/8	1 5/16	1/2	1	1 3/8	2 5/16	5 5/16	
2 1/2	1	7/8-14	3/4-16	1 1/8	1.499	1/2	7/8	1 5/16	1/2	1	1 3/8	2 5/16	5 7/16	
	1 3/4	1 1/2-12	1 1/4-12	2	2.374	3/4	1 1/2	1 11/16	3/4	1 1/2	1 7/8	2 3/16	5 15/16	
	1 3/8	1 1/4-12	1-14	1 5/8	1.999	5/8	1 1/8	1 5/16	5/8	1 1/4	1 5/8	2 9/16	5 11/16	
	5/8	1/2-20	7/16-20	3/4	1.124	3/8	1/2	9/16	1/4	5/8	1	1 15/16	5 1/16	
3 1/4	1	7/8-14	3/4-16	1 1/8	1.499	1/2	7/8	1 5/16	1/4	3/4	1 3/8	2 7/16	6	
	2	1 3/4-12	1 1/2-12	2 1/4	2.624	7/8	1 11/16	1 15/16	1/2	1 3/8	2	3 1/16	6 5/8	
	1 3/8	1 1/4-12	1-14	1 5/8	1.999	5/8	1 1/8	1 5/16	3/8	1	1 5/8	2 11/16	6 1/4	
	1 3/4	1 1/2-12	1 1/4-12	2	2.374	3/4	1 1/2	1 11/16	1/2	1 1/4	1 7/8	2 15/16	6 1/2	
4	1 3/8	1 1/4-12	1-14	1 5/8	1.999	5/8	1 1/8	1 5/16	3/8	1	1 5/8	2 11/16	6 1/4	
	2 1/2	2 1/4-12	1 7/8-12	3	3.124	1	2 1/16	2 3/8	5/8	1 5/8	2 1/4	3 5/16	6 7/8	
	1 3/4	1 1/2-12	1 1/4-12	2	2.374	3/4	1 1/2	1 11/16	1/2	1 1/4	1 7/8	2 15/16	6 1/2	
	2	1 3/4-12	1 1/2-12	2 1/4	2.624	7/8	1 11/16	1 15/16	1/2	1 3/8	2	3 1/16	6 5/8	
	1	7/8-14	3/4-16	1 1/8	1.499	1/2	7/8	1 5/16	1/4	3/4	1 3/8	2 7/16	6	
5	1 3/4	1 1/2-12	1 1/4-12	2	2.374	3/4	1 1/2	1 11/16	1/2	1 1/4	1 7/8	2 15/16	6 13/16	
	3 1/2	3 1/4-12	2 1/2-12	3 1/2	4.249	1	3	3 3/8	5/8	1 5/8	2 1/4	3 5/16	7 3/16	
	2	1 3/4-12	1 1/2-12	2 1/4	2.624	7/8	1 11/16	1 15/16	1/2	1 3/8	2	3 1/16	6 15/16	
	2 1/2	2 1/4-12	1 7/8-12	3	3.124	1	2 1/16	2 3/8	5/8	1 5/8	2 1/4	3 5/16	7 1/16	
	3	2 3/4-12	2 1/4-12	3 1/2	3.749	1	2 5/8	2 7/8	5/8	1 5/8	2 1/4	3 5/16	7 3/16	
	1	7/8-14	3/4-16	1 1/8	1.499	1/2	7/8	1 5/16	1/4	3/4	1 3/8	2 7/16	6 5/16	
	1 3/8	1 1/4-12	1-14	1 5/8	1.999	5/8	1 1/8	1 5/16	3/8	1	1 5/8	2 11/16	6 9/16	
6	1 3/4	1 1/2-12	1 1/4-12	2	2.374	3/4	1 1/2	1 11/16	3/8	1 1/8	1 7/8	3 1/16	7 5/16	
	4	3 3/4-12	3-12	4	4.749	1	3 3/8	3 7/8	1/2	1 1/2	2 1/4	3 7/16	7 11/16	
	2	1 3/4-12	1 1/2-12	2 1/4	2.624	7/8	1 11/16	1 15/16	3/8	1 1/4	2	3 3/16	7 7/16	
	2 1/2	2 1/4-12	1 7/8-12	3	3.124	1	2 1/16	2 3/8	1/2	1 1/2	2 1/4	3 7/16	7 11/16	
	3	2 3/4-12	2 1/4-12	3 1/2	3.749	1	2 5/8	2 7/8	1/2	1 1/2	2 1/4	3 7/16	7 11/16	
	3 1/2	3 1/4-12	2 1/2-12	3 1/2	4.249	1	3	3 3/8	1/2	1 1/2	2 1/4	3 7/16	7 11/16	
	1 3/8	1 1/4-12	1-14	1 5/8	1.999	5/8	1 1/8	1 5/16	1/4	7/8	1 5/8	2 13/16	7 1/16	

Cap Rectangular Flange Mount

Style MF2

1" - 1 1/2" - 2" - 2 1/2" - 5" and 6" Bore

With Maximum Oversize Rods

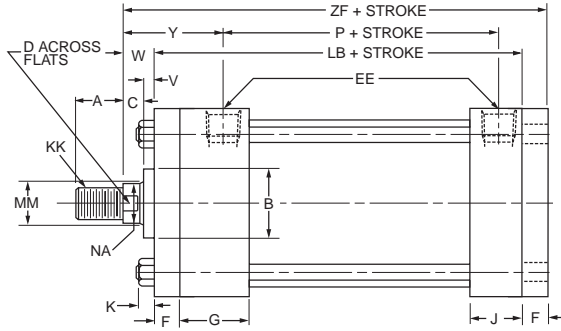
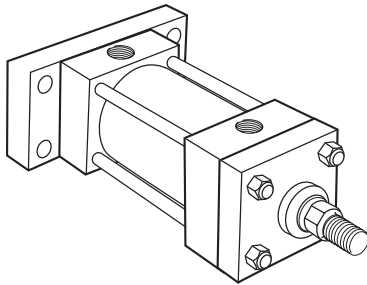

Tie Rod Retained Cartridge

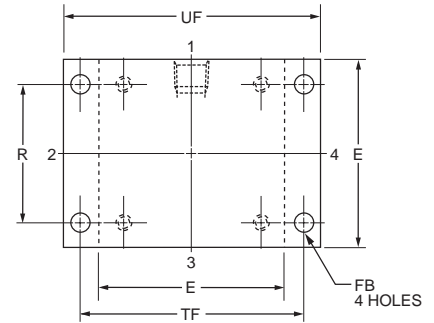

Before determining dimensions: See rod bearing cartridges chart on specifications/mountings page for cylinder rod combinations that have removable cartridges.

Cap Rectangular Flange Mount

Style MF2

1 1/2" - 6" Bore

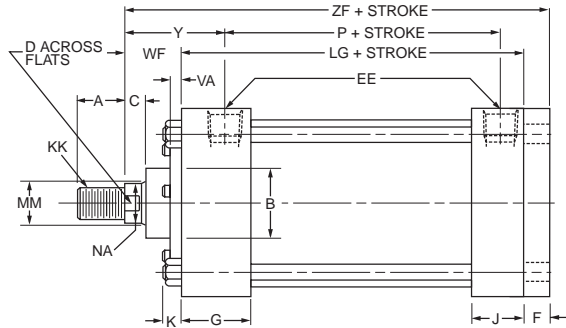
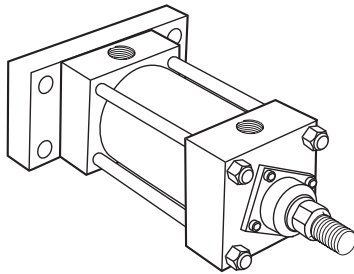

Removable Cartridge

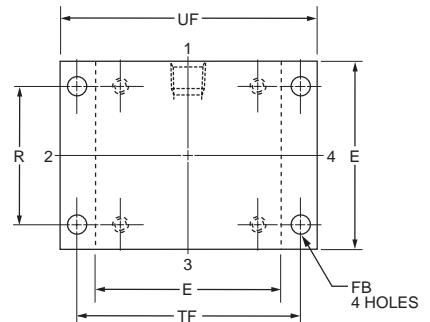

Rod End Dimensions — see table 2

Thread Style 2

Small Male

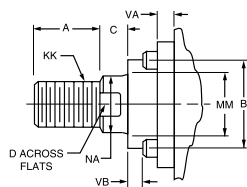

Thread Style 3

Short Female

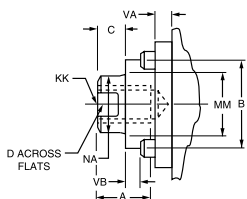

Thread Style 4

Intermediate Male

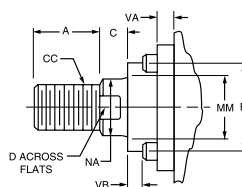

“Special” Thread Style 0

Special thread, extension, rod eye, blank, etc., are also available.

To order, specify “Style 0” and give desired dimensions for KK, A, W or WF. If otherwise special, furnish dimensioned sketch.

Straight Thread Port Adapters

Used on 1 1/2" bore size only.

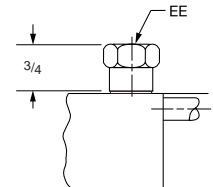

A high strength rod end stud is supplied on thread style 2 through 2" diameter rods. Larger sizes or special rod ends are cut threads. Style 2 rod ends are recommended where the workpiece is secured against the rod shoulder. When the workpiece is not shouldered, style 2 rod ends are recommended

through 2" piston rod diameters and style 4 rod ends are recommended on larger diameters. Use style 3 for applications where female rod end threads are required. If rod end is not specified, style 2 will be supplied.

Mounting Information – 1" to 6" Bore

Table 1—Envelope and Mounting Dimensions

Bore	E	EE		F	FB	G	J	K	R	TF	UF	Add Stroke		
		NPTF [⊖]	SAE*									LB	LG	P
1 [†]	■	1/4	6	3/8	1/4	1 1/2	1	3/16	1.08	2	2 1/2	3 7/8	—	2 1/8
1 1/2	2	3/8 [†]	6 [#]	3/8	5/16	1 1/2	1	1/4	1.43	2 3/4	3 3/8	4	3 5/8	2 1/4
2	2 1/2	3/8 [†]	6	3/8	3/8	1 1/2	1	5/16	1.84	3 3/8	4 1/8	4	3 5/8	2 1/4
2 1/2	3	3/8 [†]	6	3/8	3/8	1 1/2	1	5/16	2.19	3 7/8	4 5/8	4 1/8	3 3/4	2 3/8
3 1/4	3 3/4	1/2	10	5/8	7/16	1 3/4	1 1/4	3/8	2.76	4 11/16	5 1/2	—	4 1/4	2 5/8
4	4 1/2	1/2	10	5/8	7/16	1 3/4	1 1/4	3/8	3.32	5 7/16	6 1/4	—	4 1/4	2 5/8
5	5 1/2	1/2	10	5/8	9/16	1 3/4	1 1/4	7/16	4.10	6 5/8	7 5/8	5 1/8	4 1/2	2 7/8
6	6 1/2	3/4	12	3/4	9/16	2	1 1/2	7/16	4.88	7 5/8	8 5/8	5 3/4	5	3 1/8

⊖ NPTF ports will be furnished as standard unless SAE straight thread ports are specified.

* SAE straight thread ports are indicated by port number.

■ 1" bore head is 1 3/4" x 1 1/2". See mounting style MF1 page.

† On 1 1/2", 2" and 2 1/2" bore sizes the head end (only) pipe thread is not full depth on cylinders with maximum oversize rods. Minimum of 3 full threads available.

Straight thread ports. On 1-1/2" bore size an adapter fitting is required on cap end and on head end with maximum oversize rod. (See "Straight Thread Port Adapter" drawing.) Adapters are furnished as standard.

‡ Cushion adjusting needle valve for 1" bore projects beyond sides of head and cap.

Table 2—Rod End Dimensions and Envelope Dimensions Affected by Rod Size

Bore	Rod Dia. MM	Thread		Rod End Dimensions and Envelope Dimensions Affected by Rod Size											Add Stroke ZF
		Style 4 CC	Style 2 & 3 KK	A	+0.000 -0.002 B	C	D	NA	V	VA	VB	W	WF	Y	
1	1/2	7/16-20	5/16-24	5/8	.999	3/8	3/8	7/16	1/4	—	—	5/8	—	1 15/16	4 7/8
	5/8	1/2-20	7/16-20	3/4	1.124	3/8	1/2	9/16	1/4	—	—	5/8	—	1 15/16	4 7/8
1 1/2	5/8	1/2-20	7/16-20	3/4	1.124	3/8	1/2	9/16	—	1/4	3/16	—	1	1 15/16	5
	1	7/8-14	3/4-16	1 1/8	1.499	1/2	7/8	15/16	1/2	—	—	1	—	2 5/16	5 3/8
2	5/8	1/2-20	7/16-20	3/4	1.124	3/8	1/2	9/16	—	1/4	3/16	—	1	1 15/16	5
	1 3/8	1 1/4-12	1-14	1 5/8	1.999	5/8	1 1/8	1 5/16	5/8	—	—	1 1/4	—	2 9/16	5 5/8
2 1/2	1	7/8-14	3/4-16	1 1/8	1.499	1/2	7/8	15/16	—	1/4	3/8	—	1 3/8	2 5/16	5 1/2
	1 3/4	1 1/2-12	1 1/4-12	2	2.374	3/4	1 1/2	1 11/16	3/4	—	—	1 1/2	—	2 13/16	6
3 1/4	1 3/8	1 1/4-12	1-14	1 5/8	1.999	5/8	1 1/8	1 5/16	5/8	—	—	1 1/4	—	2 9/16	5 3/4
	1 3/4	1 1/2-12	1 1/4-12	2	2.374	3/4	1 1/2	1 11/16	—	1/4	3/8	—	1 3/8	2 5/16	5 1/8
4	1	7/8-14	3/4-16	1 1/8	1.499	1/2	7/8	15/16	—	1/4	3/8	—	1 3/8	2 7/16	6 1/4
	2	1 3/4-12	1 1/2-12	2 1/4	2.624	7/8	1 11/16	1 5/16	—	1/4	9/16	—	2	3 1/16	6 7/8
5	1 3/8	1 1/4-12	1-14	1 5/8	1.999	5/8	1 1/8	1 5/16	—	1/4	1/2	—	1 5/8	2 11/16	6 1/2
	2 1/2	2 1/4-12	1 7/8-12	3	3.124	1	2 1/16	2 3/8	—	1/4	1 1/16	—	2 1/4	3 5/16	7 1/8
6	1 3/4	1 1/2-12	1 1/4-12	2	2.374	3/4	1 1/2	1 11/16	—	1/4	9/16	—	1 7/8	3 1/16	7 5/8
	2	1 3/4-12	1 1/2-12	2 1/4	2.624	7/8	1 11/16	1 5/16	—	1/4	9/16	—	2	3 1/16	7 3/4
7	2 1/2	2 1/4-12	1 7/8-12	3	3.124	1	2 1/16	2 3/8	—	1/4	1 1/16	—	2 1/4	3 7/16	8
	3	2 3/4-12	2 1/4-12	3 1/2	3.749	1	2 5/8	2 7/8	5/8	—	—	1 5/8	—	3 3/16	7 3/8
8	1	7/8-14	3/4-16	1 1/8	1.499	1/2	7/8	15/16	—	1/4	3/8	—	1 3/8	2 7/16	6 1/2
	1 3/8	1 1/4-12	1-14	1 5/8	1.999	5/8	1 1/8	1 5/16	—	1/4	1/2	—	1 5/8	2 11/16	6 3/4
9	1 3/4	1 1/2-12	1 1/4-12	2	2.374	3/4	1 1/2	1 11/16	—	1/4	9/16	—	1 7/8	3 1/16	7 5/8
	2 1/2	2 1/4-12	1 7/8-12	3	3.124	1	2 1/16	2 3/8	—	1/4	1 1/16	—	2 1/4	3 7/16	8
10	2	1 3/4-12	1 1/2-12	2 1/4	2.624	7/8	1 11/16	1 5/16	—	1/4	9/16	—	2	3 1/16	7 3/4
	2 1/2	2 1/4-12	1 7/8-12	3	3.124	1	2 1/16	2 3/8	—	1/4	1 1/16	—	2 1/4	3 7/16	8
11	3	2 3/4-12	2 1/4-12	3 1/2	3.749	1	2 5/8	2 7/8	1/2	—	—	1 1/2	—	3 7/16	8
	3 1/2	3 1/4-12	2 1/2-12	3 1/2	4.249	1	3	3 3/8	1/2	—	—	1 1/2	—	3 7/16	8
12	1 3/8	1 1/4-12	1-14	1 5/8	1.999	5/8	1 1/8	1 5/16	—	1/4	7/16	—	1 5/8	2 13/16	7 3/8

Mounting Information – 1" to 6" Bore

Head Square Flange Mount
Style MF5
1" - 6" Bore

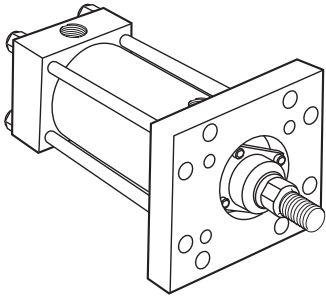

Removable Cartridge

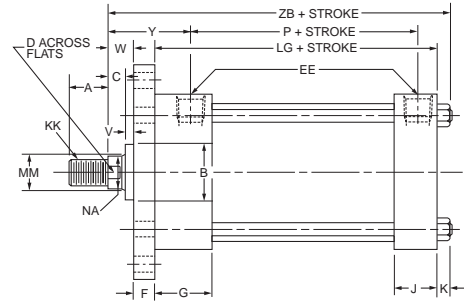
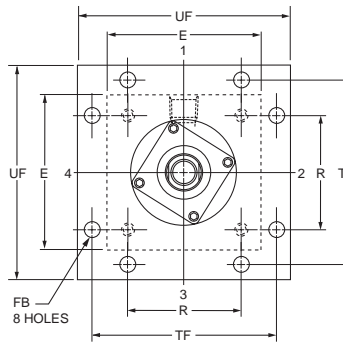

Before determining dimensions: See rod bearing cartridges chart on specifications/mountings page for cylinder rod combinations that have removable cartridges.

Cap Square Flange Mount
Style MF6
1" - 1 1/2" - 2" - 2 1/2" - 5" and 6" Bore
With Maximum Oversize Rods

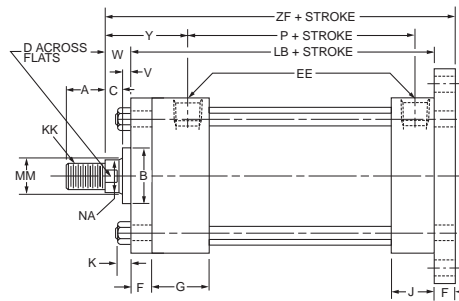
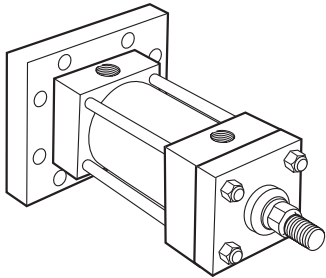

Tie Rod Retained Cartridge

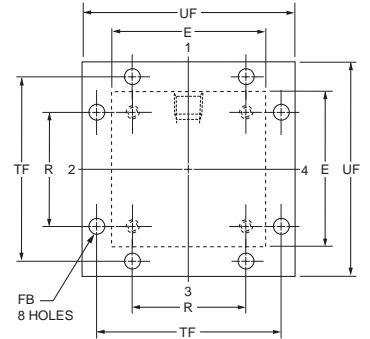

Cap Square Flange Mount
Style MF6
1 1/2" - 6" Bore

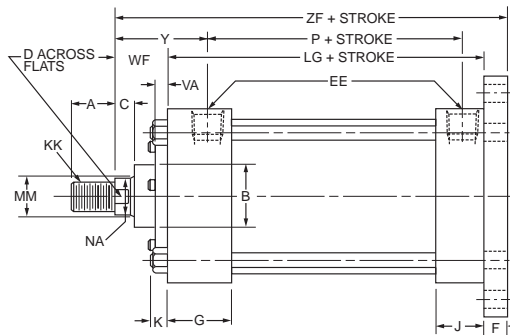
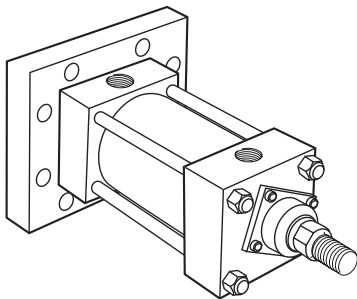

Removable Cartridge

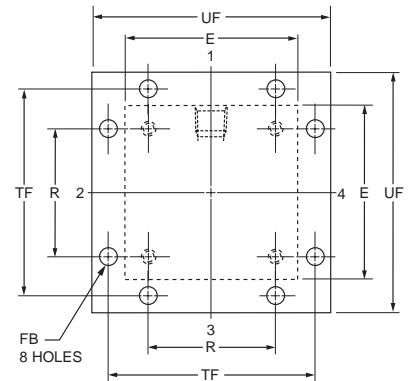

Rod End Dimensions — see table 2

Thread Style 2
Small Male

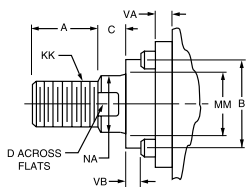

Thread Style 3
Short Female

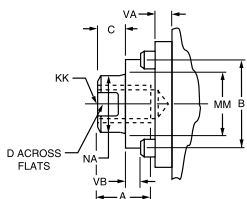

Thread Style 4
Intermediate Male

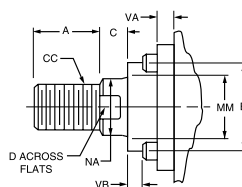

"Special" Thread Style 0

Special thread, extension, rod eye, blank, etc., are also available.

To order, specify "Style 0" and give desired dimensions for KK, A, W or WF. If otherwise special, furnish dimensioned sketch.

Straight Thread Port Adapters

Used on 1 1/2" bore size only.

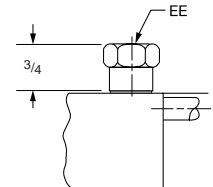

A high strength rod end stud is supplied on thread style 2 through 2" diameter rods. Larger sizes or special rod ends are cut threads. Style 2 rod ends are recommended where the workpiece is secured against the rod shoulder. When the workpiece is not shouldered, style 2 rod ends are recommended

through 2" piston rod diameters and style 4 rod ends are recommended on larger diameters. Use style 3 for applications where female rod end threads are required. If rod end is not specified, style 2 will be supplied.

Table 1—Envelope and Mounting Dimensions

Bore	E	EE		F	FB	G	J	K	R	TF	UF	Add Stroke		
		NPTF [⊖]	SAE*									LB	LG	P
1 [†]	■	1/4	6	3/8	1/4	1 1/2	1	3/16	1.08	2	2 1/2	3 7/8	—	2 1/8
1 1/2	2	3/8 [†]	6 [†]	3/8	5/16	1 1/2	1	1/4	1.43	2 3/4	3 3/8	4	3 5/8	2 1/4
2	2 1/2	3/8 [†]	6	3/8	3/8	1 1/2	1	5/16	1.84	3 3/8	4 1/8	4	3 5/8	2 1/4
2 1/2	3	3/8 [†]	6	3/8	3/8	1 1/2	1	5/16	2.19	3 7/8	4 5/8	4 1/8	3 3/4	2 3/8
3 1/4	3 3/4	1/2	10	5/8	7/16	1 3/4	1 1/4	3/8	2.76	4 11/16	5 1/2	4 7/8	4 1/4	2 5/8
4	4 1/2	1/2	10	5/8	7/16	1 3/4	1 1/4	3/8	3.32	5 7/16	6 1/4	4 7/8	4 1/4	2 5/8
5	5 1/2	1/2	10	5/8	9/16	1 3/4	1 1/4	7/16	4.10	6 5/8	7 5/8	5 1/8	4 1/2	2 7/8
6	6 1/2	3/4	12	3/4	9/16	2	1 1/2	7/16	4.88	7 5/8	8 5/8	5 3/4	5	3 1/8

⊖ NPTF ports will be furnished as standard unless SAE straight thread ports are specified.

* SAE straight thread ports are indicated by port number.

■ 1" bore head is 1 3/4" x 1 1/2". See mounting style MF1 page.

† On 1 1/2", 2" and 2 1/2" bore sizes the head end (only) pipe thread is not full depth on cylinders with maximum oversize rods. Minimum of 3 full threads available.

Straight thread ports. On 1 1/2" bore size an adapter fitting is required on cap end and on head end with maximum oversize rod. (See "Straight Thread Port Adapter" drawing.) Adapters are furnished as standard.

‡ Cushion adjusting needle valve for 1" bore projects beyond sides of head and cap.

Table 2—Rod End Dimensions and Envelope Dimensions Affected by Rod Size

Bore	Rod Dia. MM	Thread		Rod End Dimensions and Envelope Dimensions Affected by Rod Size													Add Stroke	
		Style 4 CC	Style 2 & 3 KK	A	+0.000 -0.002 B	C	D	NA	V	VA	VB	W	WF	Y	ZB	ZF		
1	1/2	7/16-20	5/16-24	5/8	.999	3/8	3/8	7/16	1/4	—	—	5/8	—	1 15/16	4 11/16	4 7/8		
	5/8	1/2-20	7/16-20	3/4	1.124	3/8	1/2	9/16	1/4	—	—	5/8	—	1 15/16	4 11/16	4 7/8		
1 1/2	5/8	1/2-20	7/16-20	3/4	1.124	3/8	1/2	9/16	1/4**	1/4	3/16	5/8	1	1 15/16	4 7/8	5		
	1	7/8-14	3/4-16	1 1/8	1.499	1/2	7/8	15/16	1/2	—	—	1	—	2 5/16	5 1/4	5 3/8		
2	5/8	1/2-20	7/16-20	3/4	1.124	3/8	1/2	9/16	1/4**	1/4	3/16	5/8	1	1 15/16	4 15/16	5		
	1 3/8	1 1/4-12	1-14	1 5/8	1.999	5/8	1 1/8	1 5/16	5/8	—	—	1 1/4	—	2 9/16	5 9/16	5 5/8		
2 1/2	1	7/8-14	3/4-16	1 1/8	1.499	1/2	7/8	1 5/16	1/2**	1/4	3/8	1	1 3/8	2 5/16	5 7/16	5 1/2		
	1 3/4	1 1/2-12	1 1/4-12	2	2.374	3/4	1 1/2	1 11/16	3/4	—	—	1 1/2	—	2 13/16	5 15/16	6		
3 1/4	1 3/8	1 1/4-12	1-14	1 5/8	1.999	5/8	1 1/8	1 5/16	5/8	—	—	1 1/4	—	2 9/16	5 11/16	5 3/4		
	5/8	1/2-20	7/16-20	3/4	1.124	3/8	1/2	9/16	1/4**	1/4	3/16	5/8	1	1 15/16	5 1/16	5 1/8		
4	1	7/8-14	3/4-16	1 1/8	1.499	1/2	7/8	1 5/16	1/4**	1/4	3/8	3/4	1 3/8	2 7/16	6	6 1/4		
	2	1 3/4-12	1 1/2-12	2 1/4	2.624	7/8	1 11/16	1 5/16	1/2**	1/4	9/16	1 3/8	2	3 1/16	6 5/8	6 7/8		
5	1 3/8	1 1/4-12	1-14	1 5/8	1.999	5/8	1 1/8	1 5/16	3/8**	1/4	1/2	1	1 5/8	2 11/16	6 1/4	6 1/2		
	3 1/4	1 1/2-12	1 1/4-12	2	2.374	3/4	1 1/2	1 11/16	1/2**	1/4	9/16	1 1/4	1 7/8	2 15/16	6 1/2	6 3/4		
6	1 3/8	1 1/4-12	1-14	1 5/8	1.999	5/8	1 1/8	1 5/16	3/8**	1/4	1/2	1	1 5/8	2 11/16	6 1/4	6 1/2		
	2 1/2	2 1/4-12	1 7/8-12	3	3.124	1	2 1/16	2 3/8	5/8**	1/4	1 1/16	1 5/8	2 1/4	3 5/16	6 7/8	7 1/8		
7	1 3/4	1 1/2-12	1 1/4-12	2	2.374	3/4	1 1/2	1 11/16	1/2**	1/4	9/16	1 1/4	1 7/8	2 15/16	6 13/16	7		
	3 1/2	3 1/4-12	2 1/2-12	3 1/2	4.249	1	3	3 3/8	5/8	—	—	1 5/8	—	3 5/16	7 3/16	7 3/8		
8	2	1 3/4-12	1 1/2-12	2 1/4	2.624	7/8	1 11/16	1 5/16	1/2**	1/4	9/16	1 3/8	2	3 1/16	6 15/16	7 1/8		
	2 1/2	2 1/4-12	1 7/8-12	3	3.124	1	2 1/16	2 3/8	5/8**	1/4	1 1/16	1 5/8	2 1/4	3 5/16	7 3/16	7 3/8		
9	3	2 3/4-12	2 1/4-12	3 1/2	3.749	1	2 5/8	2 7/8	5/8	—	—	1 5/8	—	3 5/16	7 3/16	7 3/8		
	1	7/8-14	3/4-16	1 1/8	1.499	1/2	7/8	1 5/16	1/4**	1/4	3/8	3/4	1 3/8	2 7/16	6 5/16	6 1/2		
10	1 3/8	1 1/4-12	1-14	1 5/8	1.999	5/8	1 1/8	1 5/16	3/8**	1/4	1/2	1	1 5/8	2 11/16	6 9/16	6 3/4		
	4	3 3/4-12	3-12	4	4.749	1	3 3/8	3 7/8	3/8	—	—	1 1/2	—	3 1/16	7 5/16	7 5/8		
11	2	1 3/4-12	1 1/2-12	2 1/4	2.624	7/8	1 11/16	1 5/16	1/2**	1/4	9/16	1 1/4	2	3 3/16	7 1/16	7 3/4		
	2 1/2	2 1/4-12	1 7/8-12	3	3.124	1	2 1/16	2 3/8	1/2**	1/4	1 1/16	1 1/2	2 1/4	3 7/16	7 11/16	8		
12	3	2 3/4-12	2 1/4-12	3 1/2	3.749	1	2 5/8	2 7/8	1/2	—	—	1 1/2	—	3 7/16	7 11/16	8		
	3 1/2	3 1/4-12	2 1/2-12	3 1/2	4.249	1	3	3 3/8	1/2	—	—	1 1/2	—	3 7/16	7 11/16	8		
13	1 3/8	1 1/4-12	1-14	1 5/8	1.999	5/8	1 1/8	1 5/16	1/4**	1/4	7/16	7/8	1 5/8	2 13/16	7 1/16	7 3/8		

** For all MF5 mounts; and MF6 mounts with max. oversized rods.

Tie Rods Extended Mount

Style MX1

1" - 1 1/2" - 2" - 2 1/2" - 5" and 6" Bore

With Maximum Oversize Rods

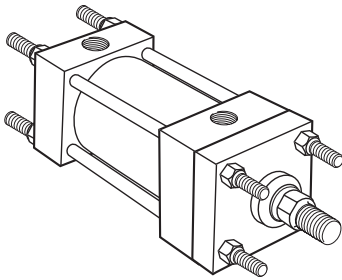

Tie Rod Retained Cartridge

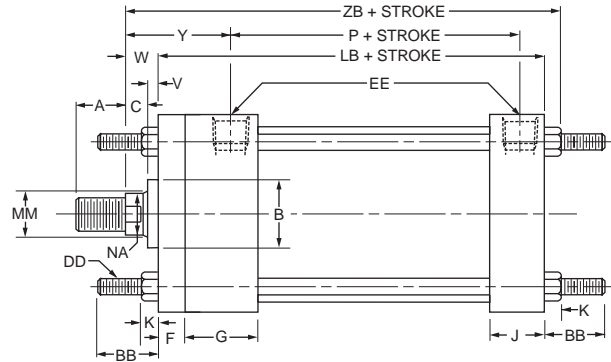
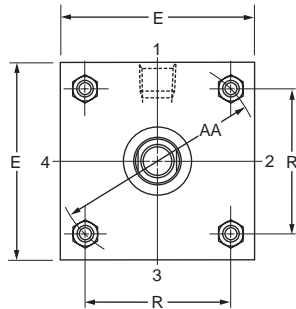

Tie rods can be extended:

Both Ends — Model MX1

Cap End — Model MX2

Head End — Model MX3

Before determining dimensions: See rod bearing cartridges chart on specifications/mountings page for cylinder rod combinations that have removable cartridges.

Tie Rods Extended Mount

Style MX1

1 1/2" - 6" Bore

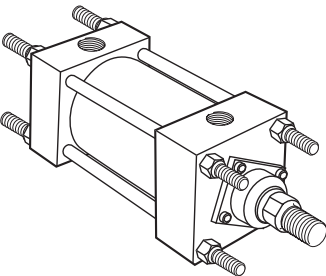

Removable Cartridge

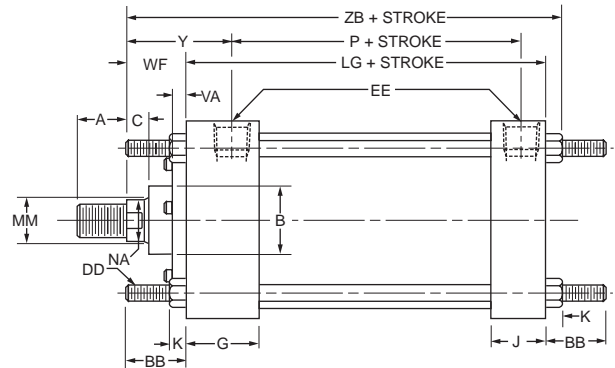
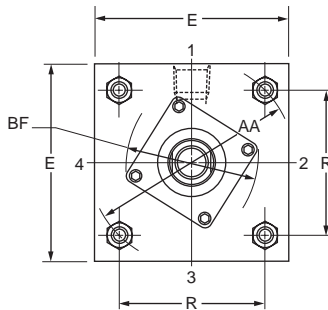

Rod End Dimensions — see table 2

Thread Style 2

Small Male

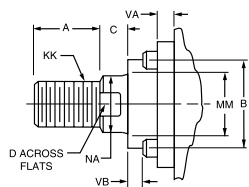

Thread Style 3

Short Female

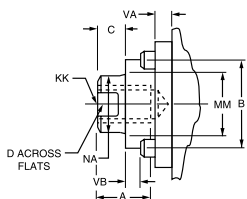

Thread Style 4

Intermediate Male

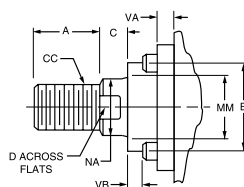

"Special" Thread Style 0

Special thread, extension, rod eye, blank, etc., are also available.

To order, specify "Style 0" and give desired dimensions for KK, A, W or WF. If otherwise special, furnish dimensioned sketch.

Straight Thread Port Adapters

Used on 1 1/2" bore size only.

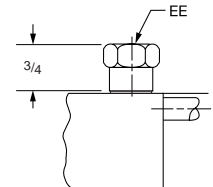

A high strength rod end stud is supplied on thread style 2 through 2" diameter rods. Larger sizes or special rod ends are cut threads. Style 2 rod ends are recommended where the workpiece is secured against the rod shoulder. When the workpiece is not shouldered, style 2 rod ends are recommended

through 2" piston rod diameters and style 4 rod ends are recommended on larger diameters. Use style 3 for applications where female rod end threads are required. If rod end is not specified, style 2 will be supplied.

Table 1—Envelope and Mounting Dimensions

Bore	AA	BB	DD	E	EE		F	G	J	K	R	Add Stroke		
					NPTF ^o	SAE*						LB	LG	P
1 [†]	1.53	3/4	10-24	■	1/4	6	3/8	1 1/2	1	3/16	1.08	3 7/8	3 1/2	2 1/8
1 1/2	2.02	1	1/4-28	2	3/8 [†]	6 [#]	3/8	1 1/2	1	1/4	1.43	4	3 5/8	2 1/4
2	2.6	1 1/8	5/16-24	2 1/2	3/8 [†]	6	3/8	1 1/2	1	5/16	1.84	4	3 5/8	2 1/4
2 1/2	3.1	1 1/8	5/16-24	3	3/8 [†]	6	3/8	1 1/2	1	5/16	2.19	4 1/8	3 3/4	2 3/8
3 1/4	3.9	1 3/8	3/8-24	3 3/4	1/2	10	—	1 3/4	1 1/4	3/8	2.76	4 7/8	4 1/4	2 5/8
4	4.7	1 3/8	3/8-24	4 1/2	1/2	10	—	1 3/4	1 1/4	3/8	3.32	4 7/8	4 1/4	2 5/8
5	5.8	1 13/16	1/2-20	5 1/2	1/2	10	5/8	1 3/4	1 1/4	7/16	4.10	5 1/8	4 1/2	2 7/8
6	6.9	1 13/16	1/2-20	6 1/2	3/4	12	3/4	2	1 1/2	7/16	4.88	5 3/4	5	3 1/8

^o NPTF ports will be furnished as standard unless SAE straight thread ports are specified.

* SAE straight thread ports are indicated by port number.

■ 1" bore head is 1 3/4" x 1 1/2". See mounting style MF1 page.

[†] On 1 1/2", 2" and 2 1/2" bore sizes the head end (only) pipe thread is not full depth on cylinders with maximum oversize rods. Minimum of 3 full threads available.

Straight thread ports. On 1 1/2" bore size an adapter fitting is required on cap end and on head end with maximum oversize rod. (See "Straight Thread Port Adapter" drawing.) Adapters are furnished as standard.

‡ Cushion adjusting needle valve for 1" bore projects beyond sides of head and cap.

Table 2—Rod End Dimensions and Envelope Dimensions Affected by Rod Size

Bore	Rod Dia. MM	Thread		Rod End Dimensions and Envelope Dimensions Affected by Rod Size													Add Stroke	
		Style 4 CC	Style 2 & 3 KK	A	+0.002 B	BF	C	D	NA	V	VA	VB	W	WF	Y	ZB		
1	1/2	7/16-20	5/16-24	5/8	.999	—	3/8	3/8	7/16	1/4	—	—	5/8	—	1 15/16	4 11/16		
	5/8	1/2-20	7/16-20	3/4	1.124	—	3/8	1/2	9/16	1/4	—	—	5/8	—	1 15/16	4 11/16		
1 1/2	5/8	1/2-20	7/16-20	3/4	1.124	1.968	3/8	1/2	9/16	—	1/4	3/16	—	1	1 15/16	4 7/8		
	1	7/8-14	3/4-16	1 1/8	1.499	—	1/2	7/8	1 5/16	1/2	—	—	1	—	2 5/16	5 1/4		
2	5/8	1/2-20	7/16-20	3/4	1.124	1.968	3/8	1/2	9/16	—	1/4	3/16	—	1	1 15/16	4 15/16		
	1 3/8	1 1/4-12	1-14	1 5/8	1.999	—	5/8	1 1/8	1 5/16	5/8	—	—	1 1/4	—	2 9/16	5 9/16		
2 1/2	1	7/8-14	3/4-16	1 1/8	1.499	2.468	1/2	7/8	1 5/16	—	1/4	3/8	—	1 3/8	2 5/16	5 7/16		
	1 3/4	1 1/2-12	1 1/4-12	2	2.374	—	3/4	1 1/2	1 11/16	3/4	—	—	1 1/2	—	2 13/16	5 5/16		
	1 3/8	1 1/4-12	1-14	1 5/8	1.999	—	5/8	1 1/8	1 5/16	5/8	—	—	1 1/4	1 5/8	2 9/16	5 11/16		
3 1/4	1	7/8-14	3/4-16	1 1/8	1.499	2.468	1/2	7/8	1 5/16	—	1/4	3/8	—	1 3/8	2 7/16	6		
	2	1 3/4-12	1 1/2-12	2 1/4	2.624	3.735	7/8	1 11/16	1 15/16	—	1/4	9/16	—	2	3 1/16	6 5/8		
	1 3/8	1 1/4-12	1-14	1 5/8	1.999	2.968	5/8	1 1/8	1 5/16	—	1/4	1/2	—	1 5/8	2 11/16	6 1/4		
	1 3/4	1 1/2-12	1 1/4-12	2	2.374	3.735	3/4	1 1/2	1 11/16	—	1/4	9/16	—	1 7/8	2 5/16	6 1/2		
4	1 3/8	1 1/4-12	1-14	1 5/8	1.999	2.968	5/8	1 1/8	1 5/16	—	1/4	1/2	—	1 5/8	2 11/16	6 1/4		
	2 1/2	2 1/4-12	1 7/8-12	3	3.124	4.312	1	2 1/16	2 3/8	—	1/4	1 1/16	—	2 1/4	3 5/16	6 7/8		
	1 3/4	1 1/2-12	1 1/4-12	2	2.374	3.735	3/4	1 1/2	1 11/16	—	1/4	9/16	—	1 7/8	2 5/16	6 1/2		
	2	1 3/4-12	1 1/2-12	2 1/4	2.624	3.735	7/8	1 11/16	1 15/16	—	1/4	9/16	—	2	3 1/16	6 5/8		
5	1	7/8-14	3/4-16	1 1/8	1.499	2.468	1/2	7/8	1 5/16	—	1/4	3/8	—	1 3/8	2 7/16	6		
	1 3/4	1 1/2-12	1 1/4-12	2	2.374	3.735	3/4	1 1/2	1 11/16	—	1/4	9/16	—	1 7/8	2 5/16	6 13/16		
	3 1/2	3 1/4-12	2 1/2-12	3 1/2	4.249	—	1	3	3 3/8	5/8	—	—	1 5/8	—	3 5/16	7 3/16		
	2	1 3/4-12	1 1/2-12	2 1/4	2.624	3.735	7/8	1 11/16	1 15/16	—	1/4	9/16	—	2	3 1/16	6 15/16		
	2 1/2	2 1/4-12	1 7/8-12	3	3.124	5.000	1	2 1/16	2 3/8	—	1/4	1 1/16	—	2 1/4	3 5/16	7 3/16		
6	3	2 3/4-12	2 1/4-12	3 1/2	3.749	—	1	2 5/8	2 7/8	5/8	—	—	1 5/8	—	3 5/16	7 3/16		
	1	7/8-14	3/4-16	1 1/8	1.499	2.468	1/2	7/8	1 5/16	—	1/4	3/8	—	1 3/8	2 7/16	6 5/16		
	1 3/8	1 1/4-12	1-14	1 5/8	1.999	2.968	5/8	1 1/8	1 5/16	—	1/4	1/2	—	1 5/8	2 11/16	6 9/16		
	1 3/4	1 1/2-12	1 1/4-12	2	2.374	3.625	3/4	1 1/2	1 11/16	—	1/4	9/16	—	1 7/8	3 1/16	7 5/16		
	4	3 3/4-12	3-12	4	4.749	—	1	3 3/8	3 7/8	1/2	—	—	1 1/2	—	3 7/16	7 11/16		
	2	1 3/4-12	1 1/2-12	2 1/4	2.624	3.735	7/8	1 11/16	1 15/16	—	1/4	9/16	—	2	3 3/16	7 7/16		
6	2 1/2	2 1/4-12	1 7/8-12	3	3.124	4.312	1	2 1/16	2 3/8	—	1/4	1 1/16	—	2 1/4	3 7/16	7 11/16		
	3	2 3/4-12	2 1/4-12	3 1/2	3.749	—	1	2 5/8	2 7/8	1/2	—	—	1 1/2	—	3 7/16	7 11/16		
	3 1/2	3 1/4-12	2 1/2-12	3 1/2	4.249	—	1	3	3 3/8	1/2	—	—	1 1/2	—	3 7/16	7 11/16		
	1 3/8	1 1/4-12	1-14	1 5/8	1.999	2.968	5/8	1 1/8	1 5/16	—	1/4	7/16	—	1 5/8	2 13/16	7 1/16		

Head Trunnion Mount

Style MT1

1" - 1 1/2" - 2" - 2 1/2" - 5" and 6" Bore

With Maximum Oversize Rods

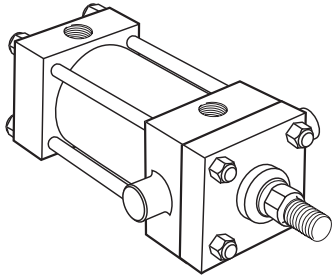

Tie Rod Retained Cartridge

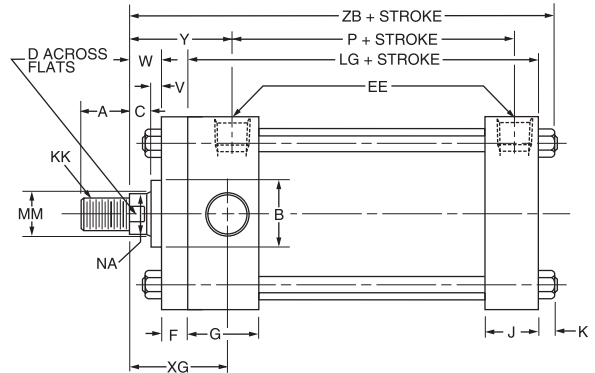
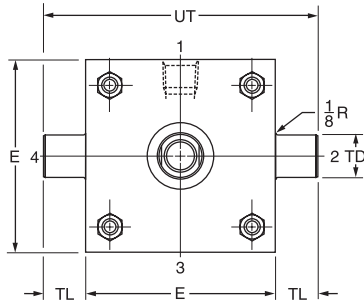

Before determining dimensions: See rod bearing cartridges chart on specifications/mountings page for cylinder rod combinations that have removable cartridges.

Head Trunnion Mount

Style MT1

1 1/2" - 6" Bore

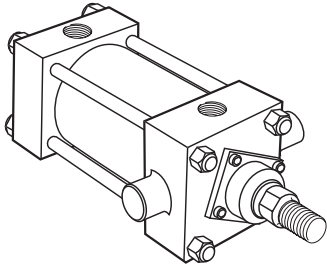

Removable Cartridge

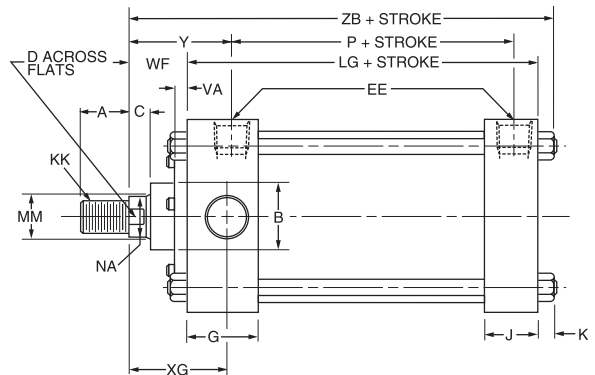
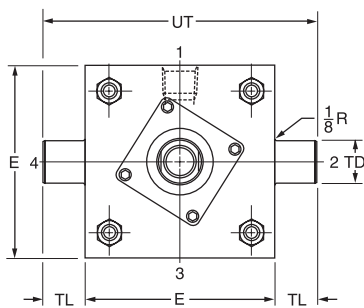

Rod End Dimensions — see table 2

Thread Style 2

Small Male

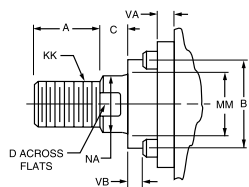

Thread Style 3

Short Female

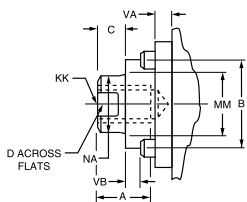

Thread Style 4

Intermediate Male

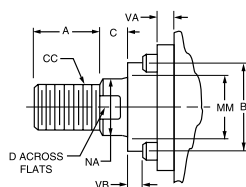

“Special” Thread Style 0

Special thread, extension, rod eye, blank, etc., are also available.

To order, specify “Style 0” and give desired dimensions for KK, A, W or WF. If otherwise special, furnish dimensioned sketch.

Straight Thread Port Adapters

Used on 1 1/2" bore size only.

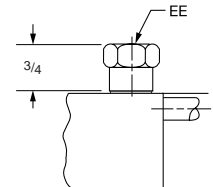

A high strength rod end stud is supplied on thread style 2 through 2" diameter rods. Larger sizes or special rod ends are cut threads. Style 2 rod ends are recommended where the workpiece is secured against the rod shoulder. When the workpiece is not shouldered, style 2 rod ends are recommended

through 2" piston rod diameters and style 4 rod ends are recommended on larger diameters. Use style 3 for applications where female rod end threads are required. If rod end is not specified, style 2 will be supplied.

Mounting Information – 1" to 6" Bore

Table 1—Envelope and Mounting Dimensions

Bore	E	EE		F	G	J	K	+.000 TD -.001	TL	UT	Add Stroke	
		NPTF [⊖]	SAE*								LG	P
1 [‡]	■	1/4	6	3/8	1 1/2	1	3/16	.750	3/4	3	3 1/2	2 1/8
1 1/2	2	3/8 [†]	6 [#]	3/8	1 1/2	1	1/4	1.000	1	4	3 5/8	2 1/4
2	2 1/2	3/8 [†]	6	3/8	1 1/2	1	5/16	1.000	1	4 1/2	3 5/8	2 1/4
2 1/2	3	3/8 [†]	6	3/8	1 1/2	1	5/16	1.000	1	5	3 3/4	2 3/8
3 1/4	3 3/4	1/2	10	—	1 3/4	1 1/4	3/8	1.000	1	5 3/4	4 1/4	2 5/8
4	4 1/2	1/2	10	—	1 3/4	1 1/4	3/8	1.000	1	6 1/2	4 1/4	2 5/8
5	5 1/2	1/2	10	5/8	1 3/4	1 1/4	7/16	1.000	1	7 1/2	4 1/2	2 7/8
6	6 1/2	3/4	12	3/4	2	1 1/2	7/16	1.375	1 3/8	9 1/4	5	3 1/8

⊖ NPTF parts will be furnished as standard unless SAE straight thread ports are specified.

* SAE straight thread ports are indicated by port number.

■ 1" bore head is 1 3/4" x 1 1/2". See mounting style MF1 page.

† On 1 1/2", 2" and 2 1/2" bore sizes the head end (only) pipe thread is not full depth on cylinders with maximum oversize rods. Minimum of 3 full threads available.

Straight thread ports. On 1 1/2" bore size an adapter fitting is required on cap end and on head end with maximum oversize rod. (See "Straight Thread Port Adapter" drawing.) Adapters are furnished as standard.

‡ Cushion adjusting needle valve for 1" bore projects beyond sides of head and cap.

Table 2—Rod End Dimensions and Envelope Dimensions Affected by Rod Size

Bore	Rod Dia. MM	Thread		Rod End Dimensions and Envelope Dimensions Affected by Rod Size													Add Stroke ZB
		Style 4 CC	Style 2 & 3 KK	A	+.000 B -.002	C	D	NA	V	VA	VB	W	WF	XG	Y		
1	1/2	7/16-20	5/16-24	5/8	.999	3/8	3/8	7/16	1/4	—	—	5/8	—	1 3/4	1 15/16	4 11/16	
	5/8	1/2-20	7/16-20	3/4	1.124	3/8	1/2	9/16	1/4	—	—	5/8	—	1 3/4	1 15/16	4 11/16	
1 1/2	5/8	1/2-20	7/16-20	3/4	1.124	3/8	1/2	9/16	—	1/4	3/16	—	1	1 3/4	1 15/16	4 7/8	
	1	7/8-14	3/4-16	1 1/8	1.499	1/2	7/8	1 5/16	1/2	—	—	1	—	2 1/8	2 5/16	5 1/4	
2	5/8	1/2-20	7/16-20	3/4	1.124	3/8	1/2	9/16	—	1/4	3/16	—	1	1 3/4	1 15/16	4 15/16	
	1 3/8	1 1/4-12	1-14	1 5/8	1.999	5/8	1 1/8	1 5/16	5/8	—	—	1 1/4	—	2 3/8	2 9/16	5 3/16	
2 1/2	1	7/8-14	3/4-16	1 1/8	1.499	1/2	7/8	1 5/16	—	1/4	3/8	—	1 3/8	2 1/8	2 5/16	5 7/16	
	1 3/4	1 1/2-12	1 1/4-12	2	2.374	3/4	1 1/2	1 11/16	3/4	—	—	1 1/2	—	2 5/8	2 13/16	5 15/16	
3 1/4	1 3/8	1 1/4-12	1-14	1 5/8	1.999	5/8	1 1/8	1 5/16	5/8	—	—	1 1/4	—	2 3/8	2 9/16	5 11/16	
	1 1/2	1 1/2-12	1 1/4-12	2	2.374	3/4	1 1/2	1 11/16	—	1/4	3/16	—	1	1 3/4	1 15/16	5 1/16	
4	1	7/8-14	3/4-16	1 1/8	1.499	1/2	7/8	1 5/16	—	1/4	3/8	—	1 3/8	2 1/4	2 7/16	6	
	2	1 3/4-12	1 1/2-12	2 1/4	2.624	7/8	1 11/16	1 15/16	—	1/4	9/16	—	2	2 7/8	3 1/16	6 5/8	
5	1 3/8	1 1/4-12	1-14	1 5/8	1.999	5/8	1 1/8	1 5/16	—	1/4	1/2	—	1 5/8	2 1/2	2 11/16	6 1/4	
	2 1/2	2 1/4-12	1 7/8-12	3	3.124	1	2 1/16	2 3/8	—	1/4	1 1/16	—	2 1/4	3 1/8	3 5/16	6 7/8	
6	1 3/4	1 1/2-12	1 1/4-12	2	2.374	3/4	1 1/2	1 11/16	—	1/4	9/16	—	1 7/8	2 3/4	2 15/16	6 1/2	
	2	1 3/4-12	1 1/2-12	2 1/4	2.624	7/8	1 11/16	1 15/16	—	1/4	9/16	—	2	2 7/8	3 1/16	6 5/8	
7	1	7/8-14	3/4-16	1 1/8	1.499	1/2	7/8	1 5/16	—	1/4	3/8	—	1 3/8	2 1/4	2 7/16	6	
	1 3/8	1 1/4-12	1-14	1 5/8	1.999	5/8	1 1/8	1 5/16	—	1/4	1/2	—	1 5/8	2 1/2	2 11/16	6 1/4	
8	1 3/4	1 1/2-12	1 1/4-12	2	2.374	3/4	1 1/2	1 11/16	—	1/4	9/16	—	1 7/8	2 3/4	2 15/16	6 1/2	
	2 1/2	2 1/4-12	1 7/8-12	3	3.124	1	2 1/16	2 3/8	—	1/4	1 1/16	—	2 1/4	3 1/8	3 5/16	6 7/8	
9	2	1 3/4-12	1 1/2-12	2 1/4	2.624	7/8	1 11/16	1 15/16	—	1/4	9/16	—	2	2 7/8	3 1/16	6 5/8	
	3	2 3/4-12	2 1/4-12	3 1/2	3.749	1	2 5/8	2 7/8	5/8	—	—	1 5/8	—	3 1/8	3 5/16	7 3/16	
10	1	7/8-14	3/4-16	1 1/8	1.499	1/2	7/8	1 5/16	—	1/4	3/8	—	1 3/8	2 1/4	2 7/16	6 5/16	
	1 3/8	1 1/4-12	1-14	1 5/8	1.999	5/8	1 1/8	1 5/16	—	1/4	1/2	—	1 5/8	2 1/2	2 11/16	6 9/16	
11	1 3/4	1 1/2-12	1 1/4-12	2	2.374	3/4	1 1/2	1 11/16	—	1/4	9/16	—	1 7/8	2 3/4	2 15/16	6 1/2	
	2	1 3/4-12	1 1/2-12	2 1/4	2.624	7/8	1 11/16	1 15/16	—	1/4	9/16	—	2	2 7/8	3 1/16	6 5/8	
12	2 1/2	2 1/4-12	1 7/8-12	3	3.124	1	2 1/16	2 3/8	—	1/4	1 1/16	—	2 1/4	3 1/8	3 5/16	7 3/16	
	3	2 3/4-12	2 1/4-12	3 1/2	3.749	1	2 5/8	2 7/8	1/2	—	—	1 1/2	—	3 1/4	3 7/16	7 11/16	
13	3 1/2	3 1/4-12	2 1/2-12	3 1/2	4.249	1	3	3 3/8	1/2	—	—	1 1/2	—	3 1/4	3 7/16	7 11/16	
	1 3/8	1 1/4-12	1-14	1 5/8	1.999	5/8	1 1/8	1 5/16	—	1/4	7/16	—	1 5/8	2 5/8	2 13/16	7 1/16	

B
PL-2
PH-2
PH-3
PHX
SHM
CHE/CHD

Cap Trunnion Mount

Style MT2

1" - 1 1/2" - 2" - 2 1/2" - 5" and 6" Bore

With Maximum Oversize Rods

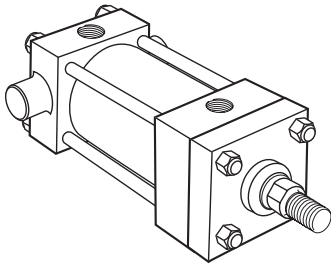

Tie Rod Retained Cartridge

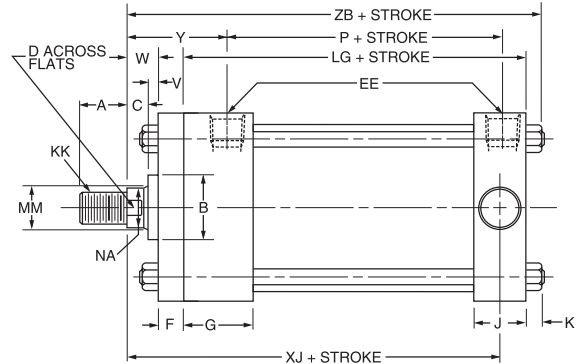
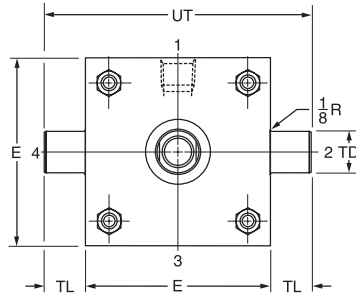

Before determining dimensions: See rod bearing cartridges chart on specifications/mountings page for cylinder rod combinations that have removable cartridges.

Cap Trunnion Mount

Style MT2

1 1/2" - 6" Bore

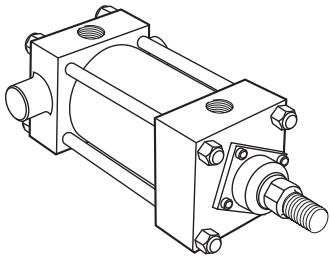

Removable Cartridge

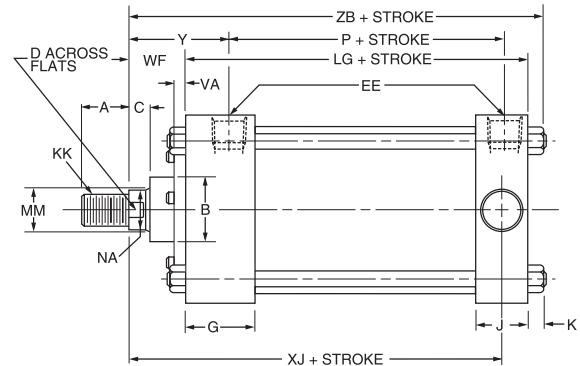
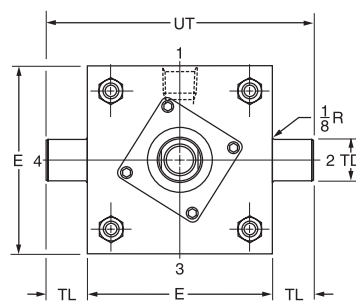

Rod End Dimensions — see table 2

Thread Style 2

Small Male

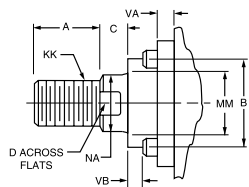

Thread Style 3

Short Female

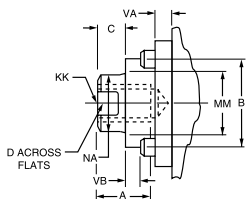

Thread Style 4

Intermediate Male

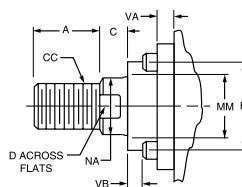

"Special" Thread Style 0

Special thread, extension, rod eye, blank, etc., are also available.

To order, specify "Style 0" and give desired dimensions for KK, A, W or WF. If otherwise special, furnish dimensioned sketch.

Straight Thread Port Adapters

Used on 1 1/2" bore size only.

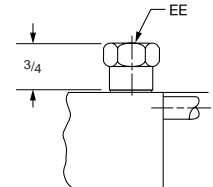

A high strength rod end stud is supplied on thread style 2 through 2" diameter rods. Larger sizes or special rod ends are cut threads. Style 2 rod ends are recommended where the workpiece is secured against the rod shoulder. When the workpiece is not shouldered, style 2 rod ends are recommended

through 2" piston rod diameters and style 4 rod ends are recommended on larger diameters. Use style 3 for applications where female rod end threads are required. If rod end is not specified, style 2 will be supplied.

Mounting Information – 1" to 6" Bore

Table 1—Envelope and Mounting Dimensions

Bore	E	EE		F	G	J	K	+0.000 TD -0.001	TL	UT	Add Stroke	
		NPTF [⊖]	SAE*								LG	P
1 [†]	■	1/4	6	3/8	1 1/2	1	3/16	.750	3/4	3	3 1/2	2 1/8
1 1/2	2	3/8 [†]	6 [#]	3/8	1 1/2	1	1/4	1.000	1	4	3 5/8	2 1/4
2	2 1/2	3/8 [†]	6	3/8	1 1/2	1	5/16	1.000	1	4 1/2	3 5/8	2 1/4
2 1/2	3	3/8 [†]	6	3/8	1 1/2	1	5/16	1.000	1	5	3 3/4	2 3/8
3 1/4	3 3/4	1/2	10	-	1 3/4	1 1/4	3/8	1.000	1	5 3/4	4 1/4	2 5/8
4	4 1/2	1/2	10	-	1 3/4	1 1/4	3/8	1.000	1	6 1/2	4 1/4	2 5/8
5	5 1/2	1/2	10	5/8	1 3/4	1 1/4	7/16	1.000	1	7 1/2	4 1/2	2 7/8
6	6 1/2	3/4	12	3/4	2	1 1/2	7/16	1.375	1 3/8	9 1/4	5	3 1/8

⊖ NPTF ports will be furnished as standard unless SAE straight thread ports are specified.

* SAE straight thread ports are indicated by port number.

■ 1" bore head is 1 3/4" x 1 1/2". See mounting style MF1 page.

† On 1 1/2", 2" and 2 1/2" bore sizes the head end (only) pipe thread is not full depth on cylinders with maximum oversize rods. Minimum of 3 full threads available.

Straight thread ports. On 1 1/2" bore size an adapter fitting is required on cap end and on head end with maximum oversize rod. (See "Straight Thread Port Adapter" drawing.) Adapters are furnished as standard.

‡ Cushion adjusting needle valve for 1" bore projects beyond sides of head and cap.

Table 2—Rod End Dimensions and Envelope Dimensions Affected by Rod Size

Bore	Rod Dia. MM	Thread		Rod End Dimensions and Envelope Dimensions Affected by Rod Size													Add Stroke ZB
		Style 4 CC	Style 2 & 3 KK	A	+0.000 -0.002 B	C	D	NA	V	VA	VB	W	WF	XJ	Y		
1	1/2	7/16-20	5/16-24	5/8	.999	3/8	3/8	7/16	1/4	—	—	5/8	—	4	1 15/16	4 11/16	
	5/8	1/2-20	7/16-20	3/4	1.124	3/8	1/2	9/16	1/4	—	—	5/8	—	4	1 15/16	4 11/16	
1 1/2	5/8	1/2-20	7/16-20	3/4	1.124	3/8	1/2	9/16	—	1/4	3/16	—	1	4 1/8	1 15/16	4 7/8	
	1	7/8-14	3/4-16	1 1/8	1.499	1/2	7/8	1 5/16	1/2	—	—	1	—	4 1/2	2 5/16	5 1/4	
2	5/8	1/2-20	7/16-20	3/4	1.124	3/8	1/2	9/16	—	1/4	3/16	—	1	4 1/8	1 15/16	4 15/16	
	1 3/8	1 1/4-12	1-14	1 5/8	1.999	5/8	1 1/8	1 5/16	5/8	—	—	1 1/4	—	4 3/4	2 9/16	5 9/16	
2 1/2	1	7/8-14	3/4-16	1 1/8	1.499	1/2	7/8	1 5/16	—	1/4	3/8	—	1 3/8	4 1/2	2 5/16	5 5/16	
	1 3/4	1 1/2-12	1 1/4-12	2	2.374	3/4	1 1/2	1 11/16	3/4	—	—	1 1/2	—	5 1/8	2 13/16	5 15/16	
3 1/4	1 3/8	1 1/4-12	1-14	1 5/8	1.999	5/8	1 1/8	1 5/16	5/8	—	—	1 1/4	1 5/8	4 7/8	2 9/16	5 11/16	
	5/8	1/2-20	7/16-20	3/4	1.124	3/8	1/2	9/16	—	1/4	3/16	—	1	4 1/4	1 15/16	5 1/16	
4	1	7/8-14	3/4-16	1 1/8	1.499	1/2	7/8	1 5/16	—	1/4	3/8	—	1 3/8	5	2 7/16	6	
	2	1 3/4-12	1 1/2-12	2 1/4	2.624	7/8	1 1/2	1 11/16	—	1/4	3/8	—	2	5 5/8	3 1/16	6 5/8	
5	1 3/8	1 1/4-12	1-14	1 5/8	1.999	5/8	1 1/8	1 5/16	—	1/4	1/2	—	1 5/8	5 1/4	2 11/16	6 1/4	
	2 1/2	2 1/4-12	1 7/8-12	3	3.124	1	2 1/16	2 3/8	—	1/4	1 1/16	—	2 1/4	5 7/8	3 5/16	6 7/8	
6	1 3/4	1 1/2-12	1 1/4-12	2	2.374	3/4	1 1/2	1 11/16	—	1/4	9/16	—	1 7/8	5 1/2	2 15/16	6 1/2	
	2	1 3/4-12	1 1/2-12	2 1/4	2.624	7/8	1 1/2	1 11/16	—	1/4	9/16	—	2	5 5/8	3 1/16	6 5/8	
5	1 3/4	1 1/2-12	1 1/4-12	2	2.374	3/4	1 1/2	1 11/16	—	1/4	9/16	—	1 7/8	5 1/2	2 15/16	6 1/2	
	3 1/2	3 1/4-12	2 1/2-12	3 1/2	4.249	1	3	3 3/8	5/8	—	—	1 5/8	—	6 1/8	3 5/16	7 3/16	
6	2	1 3/4-12	1 1/2-12	2 1/4	2.624	7/8	1 1/2	1 11/16	—	1/4	9/16	—	2	5 7/8	3 1/16	6 15/16	
	2 1/2	2 1/4-12	1 7/8-12	3	3.124	1	2 1/16	2 3/8	—	1/4	1 1/16	—	2 1/4	6 1/8	3 5/16	7 3/16	
5	3	2 3/4-12	2 1/4-12	3 1/2	3.749	1	2 5/8	2 7/8	5/8	—	—	1 5/8	—	6 1/8	3 5/16	7 3/16	
	1	7/8-14	3/4-16	1 1/8	1.499	1/2	7/8	1 5/16	—	1/4	3/8	—	1 3/8	5 1/4	2 7/16	6 5/16	
6	1 3/8	1 1/4-12	1-14	1 5/8	1.999	5/8	1 1/8	1 5/16	—	1/4	1/2	—	1 5/8	5 1/2	2 11/16	6 9/16	
	1 3/4	1 1/2-12	1 1/4-12	2	2.374	3/4	1 1/2	1 11/16	—	1/4	9/16	—	1 7/8	6 1/8	3 1/16	7 5/16	
6	4	3 3/4-12	3-12	4	4.749	1	3 3/8	3 7/8	1/2	—	—	1 1/2	—	6 1/2	3 7/16	7 11/16	
	2	1 3/4-12	1 1/2-12	2 1/4	2.624	7/8	1 1/2	1 11/16	—	1/4	9/16	—	2	6 1/4	3 5/16	7 7/16	
6	2 1/2	2 1/4-12	1 7/8-12	3	3.124	1	2 1/16	2 3/8	—	1/4	1 1/16	—	2 1/4	6 1/2	3 7/16	7 11/16	
	3	2 3/4-12	2 1/4-12	3 1/2	3.749	1	2 5/8	2 7/8	1/2	—	—	1 1/2	—	6 1/2	3 7/16	7 11/16	
6	3 1/2	3 1/4-12	2 1/2-12	3 1/2	4.249	1	3	3 3/8	1/2	—	—	1 1/2	—	6 1/2	3 7/16	7 11/16	
	1 3/8	1 1/4-12	1-14	1 5/8	1.999	5/8	1 1/8	1 5/16	—	1/4	7/16	—	1 5/8	5 7/8	2 13/16	7 1/16	

Intermediate Fixed Trunnion Mount

Style MT4

1 1/2" - 2" - 2 1/2" - 5" and 6" Bore

With Maximum Oversize Rods

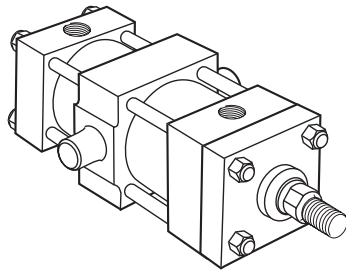

Tie Rod Retained Cartridge

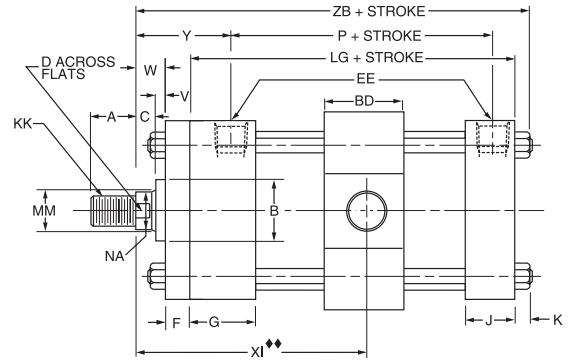
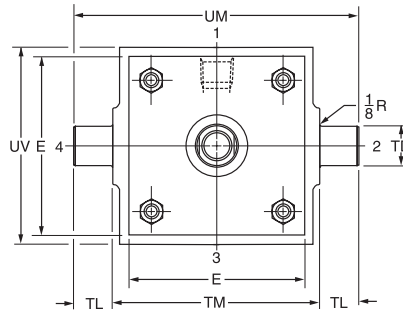

♦♦Dimension XI to be specified by customer.

Before determining dimensions: See rod bearing cartridges chart on specifications/mountings page for cylinder rod combinations that have removable cartridges.

Intermediate Fixed Trunnion Mount

Style MT4

1 1/2" - 6" Bore

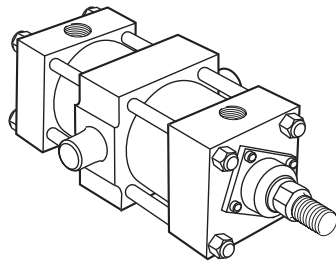

Removable Cartridge

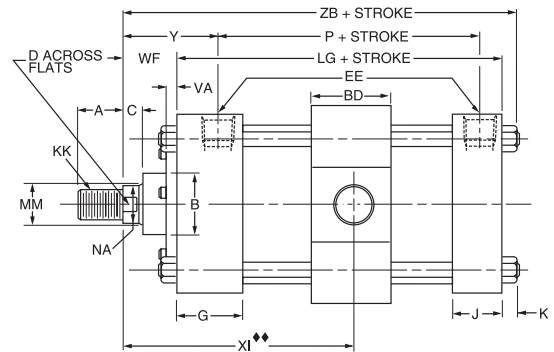
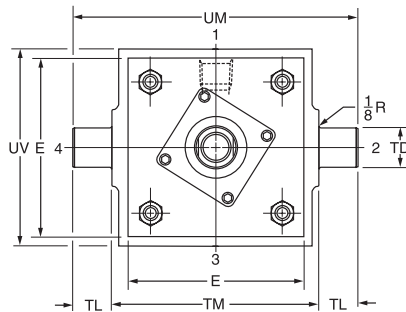

♦♦Dimension XI to be specified by customer.

Rod End Dimensions — see table 2

Thread Style 2

Small Male

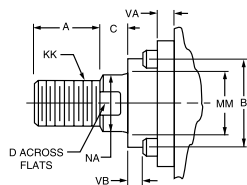

Thread Style 3

Short Female

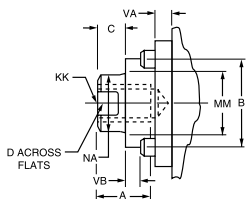

Thread Style 4

Intermediate Male

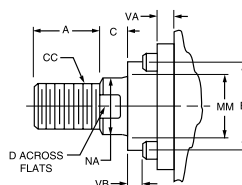

"Special" Thread Style 0

Special thread, extension, rod eye, blank, etc., are also available.

To order, specify "Style 0" and give desired dimensions for KK, A, W or WF. If otherwise special, furnish dimensioned sketch.

Straight Thread Port Adapters

Used on 1 1/2" bore size only.

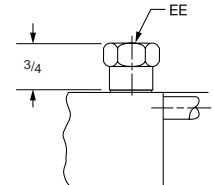

A high strength rod end stud is supplied on thread style 2 through 2" diameter rods. Larger sizes or special rod ends are cut threads. Style 2 rod ends are recommended where the workpiece is secured against the rod shoulder. When the workpiece is not shouldered, style 2 rod ends are recommended

through 2" piston rod diameters and style 4 rod ends are recommended on larger diameters. Use style 3 for applications where female rod end threads are required. If rod end is not specified, style 2 will be supplied.

Mounting Information – 1 1/2" to 6" Bore

Table 1—Envelope and Mounting Dimensions

Bore	BD	E	EE		F	G	J	K	+0.000 TD -0.001	TL	TM	UM	UV	Min. Stroke	Add Stroke	
			NPTF [⊖]	SAE* [†]											LG	P
1 1/2	1 1/4	2	3/8 [†]	6	3/8	1 1/2	1	1/4	1.000	1	2 1/2	4 1/2	2 1/2	1/4	3 5/8	2 1/4
2	1 1/2	2 1/2	3/8 [†]	6 [#]	3/8	1 1/2	1	5/16	1.000	1	3	5	3	1/2	3 5/8	2 1/4
2 1/2	1 1/2	3	3/8 [†]	6	3/8	1 1/2	1	5/16	1.000	1	3 1/2	5 1/2	3 1/2	3/8	3 3/4	2 3/8
3 1/4	2	3 3/4	1/2	10	—	1 3/4	1 1/4	3/8	1.000	1	4 1/2	6 1/2	4 1/4	7/8	4 1/4	2 5/8
4	2	4 1/2	1/2	10	—	1 3/4	1 1/4	3/8	1.000	1	5 1/4	7 1/4	5	7/8	4 1/4	2 5/8
5	2	5 1/2	1/2	10	5/8	1 3/4	1 1/4	7/16	1.000	1	6 1/4	8 1/4	6	5/8	4 1/2	2 7/8
6	2 1/2	6 1/2	3/4	12	3/4	2	1 1/2	7/16	1.375	1 3/8	7 5/8	10 3/8	7	1 1/8	5	3 1/8

⊖ NPTF ports will be furnished as standard unless SAE straight thread ports are specified.

* SAE straight thread ports are indicated by port number.

‡ Cushion adjusting needle valve for 1" bore projects beyond sides of head and cap.

† On 1 1/2", 2" and 2 1/2" bore sizes the head end (only) pipe thread is not full depth on cylinders with maximum oversize rods. Minimum of 3 full threads available.

Straight thread ports. On 1 1/2" bore size an adapter fitting is required on cap end and on head end with maximum oversize rod. (See "Straight Thread Port Adapter" drawing.) Adapters are furnished as standard.

Table 2—Rod End Dimensions and Envelope Dimensions Affected by Rod Size

Bore	Rod Dia. MM	Thread		Rod End Dimensions and Envelope Dimensions Affected by Rod Size													
		Style 4 CC	Style 2 & 3 KK	A	+0.000 -0.002 B	C	D	NA	V	VA	VB	W	WF	Min.♦♦ XI	Y	Add Stroke ZB	
1 1/2	5/8	1/2-20	7/16-20	3/4	1.124	3/8	1/2	9/16	—	1/4	3/16	—	1	3 3/16	1 15/16	4 7/8	
	1	7/8-14	3/4-16	1 1/8	1.499	1/2	7/8	15/16	1/2	—	—	1	—	3 9/16	2 2/16	5 1/4	
2	5/8	1/2-20	7/16-20	3/4	1.124	3/8	1/2	9/16	—	1/4	3/16	—	1	3 5/16	1 15/16	4 15/16	
	1 3/8	1 1/4-12	1-14	1 5/8	1.999	5/8	1 1/8	1 5/16	5/8	—	—	1 1/4	—	3 15/16	2 2/16	5 5/16	
2 1/2	1	7/8-14	3/4-16	1 1/8	1.499	1/2	7/8	15/16	—	1/4	3/8	—	1 3/8	3 11/16	2 5/16	5 5/16	
	1 3/4	1 1/2-12	1 1/4-12	2	2.374	3/4	1 1/2	1 11/16	3/4	—	—	1 1/2	—	4 3/16	2 13/16	5 5/16	
3 1/4	5/8	1/2-20	7/16-20	3/4	1.124	3/8	1/2	9/16	—	1/4	3/16	—	1	3 5/16	1 15/16	5 1/16	
	1	7/8-14	3/4-16	1 1/8	1.499	1/2	7/8	15/16	—	1/4	3/8	—	1 3/8	4 3/16	2 7/16	6	
3 1/4	2	1 3/4-12	1 1/2-12	2 1/4	2.624	7/8	1 1/8	1 15/16	—	1/4	9/16	—	2	4 13/16	3 1/16	6 5/8	
	1 3/8	1 1/4-12	1-14	1 5/8	1.999	5/8	1 1/8	1 5/16	—	1/4	1/2	—	1 5/8	4 7/16	2 11/16	6 1/4	
4	1 3/4	1 1/2-12	1 1/4-12	2	2.374	3/4	1 1/2	1 11/16	—	1/4	9/16	—	1 7/8	4 11/16	2 15/16	6 1/2	
	1 3/8	1 1/4-12	1-14	1 5/8	1.999	5/8	1 1/8	1 5/16	—	1/4	1/2	—	1 5/8	4 7/16	2 11/16	6 1/4	
4	2 1/2	2 1/4-12	1 7/8-12	3	3.124	1	2 1/16	2 3/8	—	1/4	1 1/16	—	2 1/4	5 1/16	3 5/16	6 7/8	
	1 3/4	1 1/2-12	1 1/4-12	2	2.374	3/4	1 1/2	1 11/16	—	1/4	9/16	—	1 7/8	4 11/16	2 15/16	6 1/2	
5	2	1 3/4-12	1 1/2-12	2 1/4	2.624	7/8	1 1/8	1 15/16	—	1/4	9/16	—	2	4 13/16	3 1/16	6 5/8	
	1	7/8-14	3/4-16	1 1/8	1.499	1/2	7/8	15/16	—	1/4	3/8	—	1 3/8	4 3/16	2 7/16	6	
5	1 3/8	1 1/4-12	1-14	1 5/8	1.999	5/8	1 1/8	1 5/16	—	1/4	1/2	—	1 5/8	4 7/16	2 11/16	6 9/16	
	1 3/4	1 1/2-12	1 1/4-12	2	2.374	3/4	1 1/2	1 11/16	—	1/4	9/16	—	1 7/8	5 3/16	3 1/16	7 5/16	
6	4	3 3/4-12	3-12	4	4.749	1	3 3/8	3 7/8	1/2	—	—	1 1/2	—	5 9/16	3 7/16	7 11/16	
	2	1 3/4-12	1 1/2-12	2 1/4	2.624	7/8	1 1/8	1 15/16	—	1/4	9/16	—	2	5 5/16	3 3/16	7 7/16	
6	2 1/2	2 1/4-12	1 7/8-12	3	3.124	1	2 1/16	2 3/8	—	1/4	1 1/16	—	2 1/4	5 9/16	3 1/16	7 11/16	
	3	2 3/4-12	2 1/4-12	3 1/2	3.749	1	2 5/8	2 7/8	1/2	—	—	1 1/2	—	5 9/16	3 1/16	7 11/16	
6	3 1/2	3 1/4-12	2 1/2-12	3 1/2	4.249	1	3	3 3/8	1/2	—	—	1 1/2	—	5 9/16	3 1/16	7 11/16	
	1 3/8	1 1/4-12	1-14	1 5/8	1.999	5/8	1 1/8	1 5/16	—	1/4	7/16	—	1 5/8	4 15/16	2 13/16	7 1/16	

♦♦Dimension XI to be specified by customer.

Cap Fixed Clevis Mount

Style MP1

1" - 1 1/2" - 2" - 2 1/2" - 5" and 6" Bore
With Maximum Oversize Rods

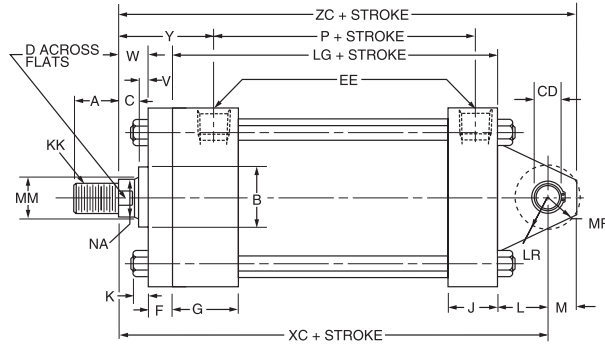
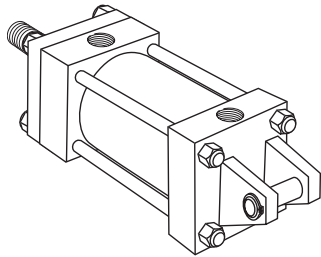

Tie Rod Retained Cartridge

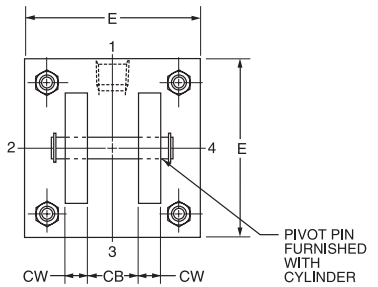

Note: The 1", 4", 5" and 6" bore sizes have tie rod nuts at both ends as shown. Tie rods thread into cap on all other bore sizes.

Before determining dimensions: See rod bearing cartridges chart on specifications/mountings page for cylinder rod combinations that have removable cartridges.

Cap Fixed Clevis Mount

Style MP1

1 1/2" - 6" Bore

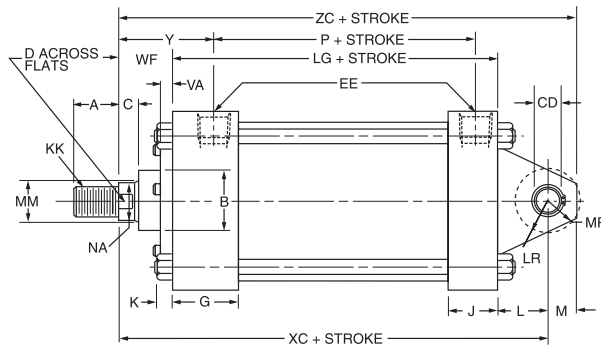
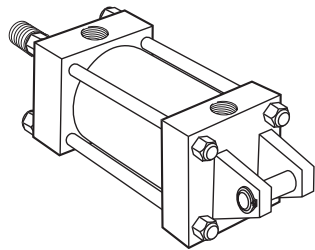

Removable Cartridge

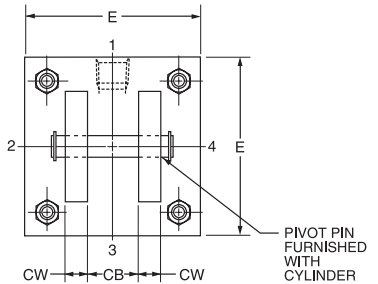

Note: The 1", 4", 5" and 6" bore sizes have tie rod nuts at both ends as shown. Tie rods thread into cap on all other bore sizes.

Rod End Dimensions — see table 2

Thread Style 2

Small Male

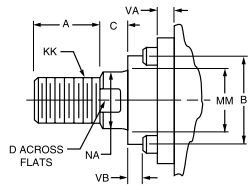

Thread Style 3

Short Female

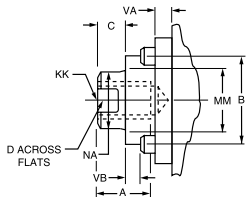

Thread Style 4

Intermediate Male

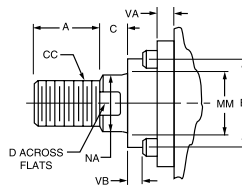

"Special" Thread Style 0

Special thread, extension, rod eye, blank, etc., are also available.

To order, specify "Style 0" and give desired dimensions for KK, A, W or WF. If otherwise special, furnish dimensioned sketch.

Straight Thread Port Adapters

Used on 1 1/2" bore size only.

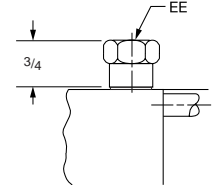

A high strength rod end stud is supplied on thread style 2 through 2" diameter rods. Larger sizes or special rod ends are cut threads. Style 2 rod ends are recommended where the workpiece is secured against the rod shoulder. When the workpiece is not shouldered, style 2 rod ends are recommended

through 2" piston rod diameters and style 4 rod ends are recommended on larger diameters. Use style 3 for applications where female rod end threads are required. If rod end is not specified, style 2 will be supplied.

Mounting Information – 1" to 6" Bore

Table 1—Envelope and Mounting Dimensions

Bore	CB	+.000 CD ^A -.002	CW	E	EE		F	G	J	K	L	LR	M	MR	Add Stroke	
					NPTF [⊖]	SAE [*]									LG	P
1 [‡]	•	.441 [•]	•	■	1/4	6	3/8	1 1/2	1	3/16	1/2 [•]	1/2 [•]	7/16 [•]	1/2 [•]	3 1/2 [•]	2 1/8
1 1/2	3/4	.501	1/2	2	3/8 [†]	6 [#]	3/8	1 1/2	1	1/4	3/4	3/4	1/2	5/8	3 5/8	2 1/4
2	3/4	.501	1/2	2 1/2	3/8 [†]	6	3/8	1 1/2	1	5/16	3/4	3/4	1/2	5/8	3 5/8	2 1/4
2 1/2	3/4	.501	1/2	3	3/8 [†]	6	3/8	1 1/2	1	5/16	3/4	3/4	1/2	5/8	3 3/4	2 3/8
3 1/4	1 1/4	.751	5/8	3 3/4	1/2	10	—	1 3/4	1 1/4	3/8	1 1/4	1	3/4	15/16	4 1/4	2 5/8
4	1 1/4	.751	5/8	4 1/2	1/2	10	—	1 3/4	1 1/4	3/8	1 1/4	1	3/4	15/16	4 1/4	2 5/8
5	1 1/4	.751	5/8	5 1/2	1/2	10	5/8	1 3/4	1 1/4	7/16	1 1/4	1	3/4	15/16	4 1/2	2 7/8
6	1 1/2	1.001	3/4	6 1/2	3/4	12	3/4	2	1 1/2	7/16	1 1/2	1 1/4	1	1 3/16	5	3 1/8

⊖ NPTF ports will be furnished as standard unless SAE straight thread ports are specified.

* SAE straight thread ports are indicated by port number.

■ 1" bore head is 1 3/4" x 1 1/2". See mounting style MF1 page.

† On 1 1/2", 2" and 2 1/2" bore sizes the head end (only) pipe thread is not full depth on cylinders with maximum oversize rods. Minimum of 3 full threads available.

Straight thread ports. On 1 1/2" bore size an adapter fitting is required on cap end and on head end with maximum oversize rod. (See "Straight Thread Port Adapter" drawing.) Adapters are furnished as standard.

▲ Dimension CD is pin diameter except in 1" bore.

• In 1" bore size only, a single fixed eye mounting 7/16" thick is used. Dimension CD (.441") is hole diameter — pin not supplied.

‡ Cushion adjusting needle valve for 1" bore projects beyond sides of head and cap.

Table 2—Rod End Dimensions and Envelope Dimensions Affected by Rod Size

Bore	Rod Dia. MM	Thread		Rod End Dimensions and Envelope Dimensions Affected by Rod Size													Add Stroke	
		Style 4 CC	Style 2 & 3 KK	A	+.000 -.002 B	C	D	NA	V	VA	VB	W	WF	Y	XC	ZC		
1	1/2	7/16-20	5/16-24	5/8	.999	3/8	3/8	7/16	1/4	—	—	5/8	—	1 15/16	5	5 7/16		
	5/8	1/2-20	7/16-20	3/4	1.124	3/8	1/2	9/16	1/4	—	—	5/8	—	1 15/16	5	5 7/16		
1 1/2	5/8	1/2-20	7/16-20	3/4	1.124	3/8	1/2	9/16	—	1/4	3/16	—	1	1 15/16	5 3/8	5 7/8		
	1	7/8-14	3/4-16	1 1/8	1.499	1/2	7/8	15/16	1/2	—	—	1	—	2 5/16	5 3/4	6 1/4		
2	5/8	1/2-20	7/16-20	3/4	1.124	3/8	1/2	9/16	—	1/4	3/16	—	1	1 15/16	5 3/8	5 7/8		
	1 3/8	1 1/4-12	1-14	1 5/8	1.999	5/8	1 1/8	1 5/16	5/8	—	—	1 1/4	—	2 9/16	6	6 1/2		
2 1/2	1	7/8-14	3/4-16	1 1/8	1.499	1/2	7/8	15/16	—	1/4	3/8	—	1 3/8	2 5/16	5 3/4	6 1/4		
	1 3/4	1 1/2-12	1 1/4-12	2	2.374	3/4	1 1/2	1 11/16	3/4	—	—	1 1/2	—	2 13/16	6 3/8	6 7/8		
3 1/4	1 3/8	1 1/4-12	1-14	1 5/8	1.999	5/8	1 1/8	1 5/16	5/8	—	—	1 1/4	1 5/8	2 9/16	6 1/8	6 5/8		
	1 3/4	1 1/2-12	1 1/4-12	2	2.374	3/4	1 1/2	1 11/16	—	1/4	3/16	—	1	1 15/16	5 1/2	6		
4	1	7/8-14	3/4-16	1 1/8	1.499	1/2	7/8	15/16	—	1/4	3/8	—	1 3/8	2 7/16	6 7/8	7 5/8		
	2	1 3/4-12	1 1/2-12	2 1/4	2.624	7/8	1 11/16	1 15/16	—	1/4	9/16	—	2	3 1/16	7 1/2	8 1/4		
5	1 3/8	1 1/4-12	1-14	1 5/8	1.999	5/8	1 1/8	1 5/16	—	1/4	1/2	—	1 5/8	2 11/16	7 1/8	7 7/8		
	2 1/2	2 1/4-12	1 7/8-12	3	3.124	1	2 1/16	2 3/8	—	1/4	1 1/16	—	2 1/4	3 5/16	7 3/4	8 1/2		
6	1 3/4	1 1/2-12	1 1/4-12	2	2.374	3/4	1 1/2	1 11/16	—	1/4	9/16	—	1 7/8	3 1/16	8 3/8	9 3/8		
	4	3 3/4-12	3-12	4	4.749	1	3 3/8	3 7/8	1/2	—	—	1 1/2	—	3 7/16	8 3/4	9 3/4		
6	2	1 3/4-12	1 1/2-12	2 1/4	2.624	7/8	1 11/16	1 15/16	—	1/4	9/16	—	2	3 3/16	8 1/2	9 1/2		
	2 1/2	2 1/4-12	1 7/8-12	3	3.124	1	2 1/16	2 3/8	—	1/4	1 1/16	—	2 1/4	3 7/16	8 3/4	9 3/4		
6	3	2 3/4-12	2 1/4-12	3 1/2	3.749	1	2 5/8	2 7/8	1/2	—	—	1 1/2	—	3 7/16	8 3/4	9 3/4		
	3 1/2	3 1/4-12	2 1/2-12	3 1/2	4.249	1	3	3 3/8	1/2	—	—	1 1/2	—	3 7/16	8 3/4	9 3/4		
6	1 3/8	1 1/4-12	1-14	1 5/8	1.999	5/8	1 1/8	1 5/16	—	1/4	7/16	—	1 5/8	2 13/16	8 1/8	9 1/8		

Tie Rods Extended Mount
Style MX3

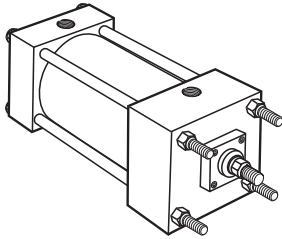

Model MX3, Head Tie Rods Extended, illustrated; Model MX2 Cap Tie Rods Extended; and Model MX1. Both Ends Tie Rods Extended are also available. All Extended Tie Rods can be dimensioned from Model MX3 drawing at right.

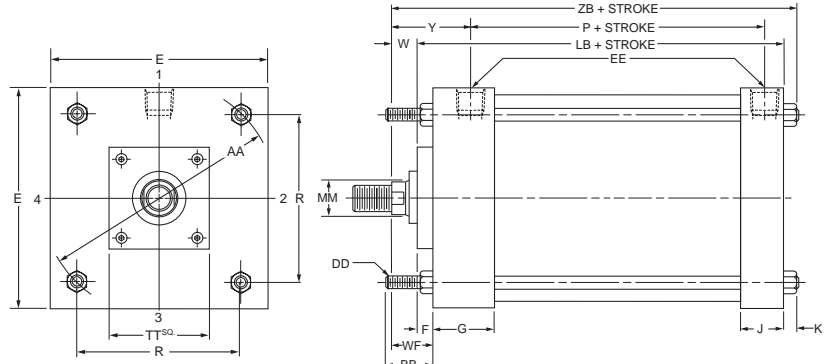

Mounting Model MX3 and MX1 not offered in 8" bore size, rod diameter 4 1/2", 5" and 5 1/2".

Head Square Mount
Style ME3

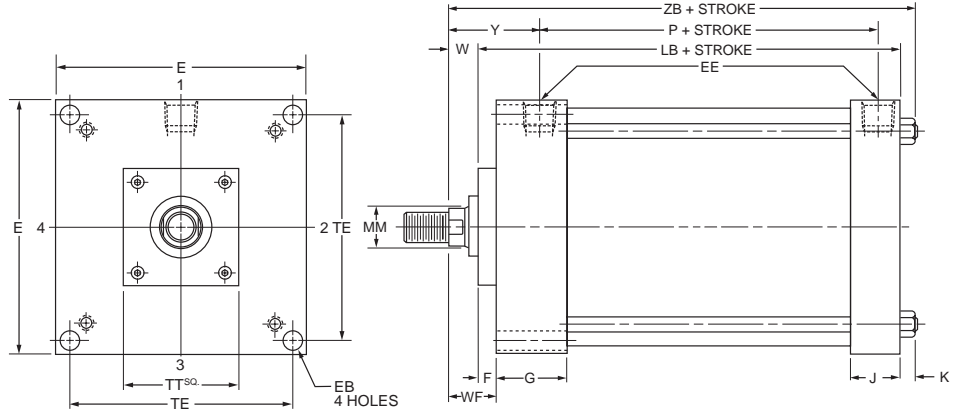
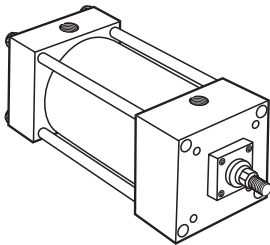

Cap Square Mount
Style ME4

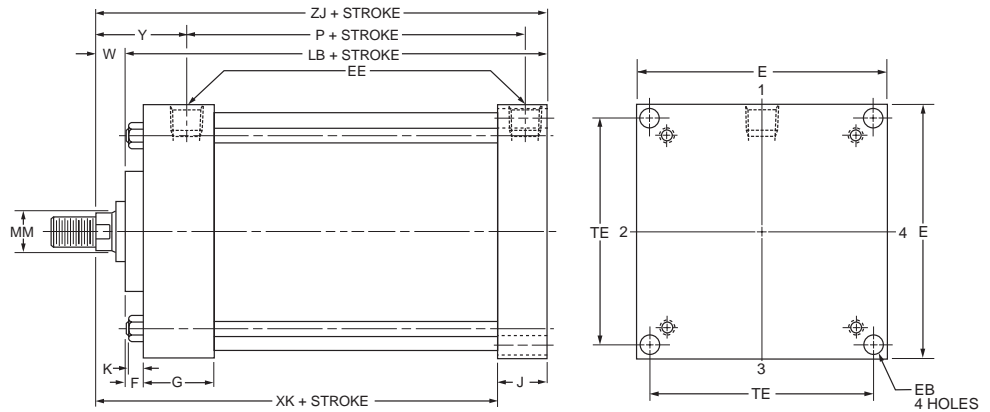
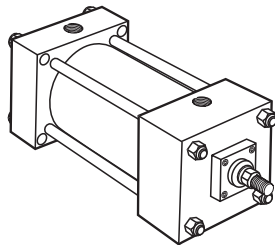

Rod End Dimensions — see table 2 or 5

Thread Style 2
Small Male

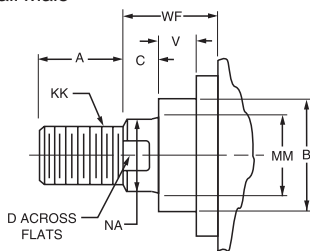

Thread Style 3
Short Female

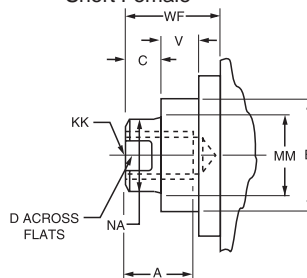

Thread Style 4
Intermediate Male

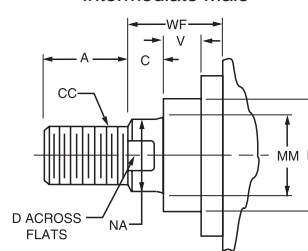

"Special" Thread Style 0

Special thread, extension, rod eye, blank, etc., are also available.

To order, specify "Style 0" and give desired dimensions for KK, A, W or WF. If otherwise special, furnish dimensioned sketch.

A high strength rod end stud is supplied on thread style 2 through 2" diameter rods. Larger sizes or special rod ends are cut threads. Style 2 rod ends are recommended where the workpiece is secured against the rod shoulder. When the workpiece is not shouldered, style 2 rod

ends are recommended through 2" piston rod diameters and style 4 rod ends are recommended on larger diameters. Use style 3 for applications where female rod end threads are required. If rod end is not specified, style 2 will be supplied.

Table 1—Envelope and Mounting Dimensions—Style MX3

Bore	AA	BB	DD	E	EE		F	G	J	K	R	Add Stroke	
					NPTF [⊖]	SAE*						LB	P
8	9.1	2 ⁵ / ₁₆	5 ⁵ / ₈ -18	8 ¹ / ₂	3 ³ / ₄	12	3 ³ / ₄	2	1 ¹ / ₂	9 ⁹ / ₁₆	6.44	5 ⁷ / ₈	3 ¹ / ₄

⊖ NPTF ports will be furnished as standard unless SAE straight thread ports are specified.

* SAE straight thread ports are indicated by port number.

Table 2—Rod End Dimensions—Style MX3

Bore	Rod Dia. MM	Thread		Rod Extensions and Pilot Dimensions								Add Stroke			
		Style 4 CC	Style 2 & 3 KK	A	+0.000 -0.002 B	C	D	LA	NA	V	W	TT	WF	Y	ZB
8	2	1 ³ / ₄ -12	1 ¹ / ₂ -12	2 ¹ / ₄	2.624	7 ⁷ / ₈	1 ¹¹ / ₁₆	3 ¹ / ₂	1 ¹⁵ / ₁₆	3 ³ / ₈	1 ¹ / ₄	4	2	3 ³ / ₁₆	7 ¹¹ / ₁₆
	5 ¹ / ₂	5 ¹ / ₄ -12	4-12	5 ¹ / ₂	6.249	1	4 ⁵ / ₈	7	5 ³ / ₈	1 ¹ / ₂	1 ¹ / ₂	7	2 ¹ / ₄	3 ⁷ / ₁₆	7 ¹⁵ / ₁₆
	2 ¹ / ₂	2 ¹ / ₄ -12	1 ⁷ / ₈ -12	3	3.124	1	2 ¹ / ₁₆	4 ¹ / ₂	2 ³ / ₈	1 ¹ / ₂	1 ¹ / ₂	4	2 ¹ / ₄	3 ⁷ / ₁₆	7 ¹⁵ / ₁₆
	3	2 ³ / ₄ -12	2 ¹ / ₄ -12	3 ¹ / ₂	3.749	1	2 ⁵ / ₈	5	2 ⁷ / ₈	1 ¹ / ₂	1 ¹ / ₂	5 ¹ / ₂	2 ¹ / ₄	3 ⁷ / ₁₆	7 ¹⁵ / ₁₆
	3 ¹ / ₂	3 ¹ / ₄ -12	2 ¹ / ₂ -12	3 ¹ / ₂	4.249	1	3	5	3 ³ / ₈	1 ¹ / ₂	1 ¹ / ₂	5 ¹ / ₂	2 ¹ / ₄	3 ⁷ / ₁₆	7 ¹⁵ / ₁₆
	4	3 ³ / ₄ -12	3-12	4	4.749	1	3 ³ / ₈	5 ¹ / ₂	3 ⁷ / ₈	1 ¹ / ₂	1 ¹ / ₂	5 ¹ / ₂	2 ¹ / ₄	3 ⁷ / ₁₆	7 ¹⁵ / ₁₆
	1 ³ / ₈	1 ¹ / ₄ -12	1-14	1 ⁵ / ₈	1.999	5 ⁵ / ₈	1 ¹ / ₈	2 ¹ / ₂	1 ⁵ / ₁₆	1 ¹ / ₄	7 ⁷ / ₈	4	1 ⁵ / ₈	2 ¹³ / ₁₆	7 ⁵ / ₁₆
	1 ³ / ₄	1 ¹ / ₂ -12	1 ¹ / ₄ -12	2	2.374	3 ³ / ₄	1 ¹ / ₂	3 ¹ / ₈	1 ¹¹ / ₁₆	3 ³ / ₈	1 ¹ / ₈	4	1 ⁷ / ₈	3 ¹ / ₁₆	7 ⁹ / ₁₆
	4 ¹ / ₂	4 ¹ / ₄ -12	3 ¹ / ₄ -12	4 ¹ / ₂	5.249	1	3 ⁷ / ₈	6	4 ³ / ₈	1 ¹ / ₂	1 ¹ / ₂	7	2 ¹ / ₄	3 ⁷ / ₁₆	7 ¹⁵ / ₁₆
5	4 ³ / ₄ -12	3 ¹ / ₂ -12	5	5.749	1	4 ¹ / ₄	6 ¹ / ₂	4 ⁷ / ₈	1 ¹ / ₂	1 ¹ / ₂	7	2 ¹ / ₄	3 ⁷ / ₁₆	7 ¹⁵ / ₁₆	

Table 3 — Envelope and Mounting Dimensions

Table 4—Envelope and Mounting Dimensions—Styles ME3 and ME4

Bore	E	EB	EE		F	G	J	K	TE	Add Stroke	
			NPTF [⊖]	SAE*						LB	P
8	8 ¹ / ₂	1 ¹ / ₁₆	3 ³ / ₄	12	3 ³ / ₄	2	1 ¹ / ₂	9 ⁹ / ₁₆	7.57	5 ⁷ / ₈	3 ¹ / ₄

⊖ NPTF ports will be furnished as standard unless SAE straight thread ports are specified.

* SAE straight thread ports are indicated by port number.

Table 5—Rod End Dimensions—Styles ME3 and ME4

Bore	Rod Dia. MM	Thread		Rod Extensions and Pilot Dimensions								Add Stroke					
		Style 4 CC	Style 2 & 3 KK	A	+0.000 -0.002 B	C	D	LA	NA	V	W	TT	WF	Y	XK	ZB	ZJ
8	2	1 ³ / ₄ -12	1 ¹ / ₂ -12	2 ¹ / ₄	2.624	7 ⁷ / ₈	1 ¹¹ / ₁₆	3 ¹ / ₂	1 ¹⁵ / ₁₆	3 ³ / ₈	1 ¹ / ₄	4	2	3 ³ / ₁₆	5 ⁵ / ₈	7 ¹¹ / ₁₆	7 ¹ / ₈
	5 ¹ / ₂	5 ¹ / ₄ -12	4-12	5 ¹ / ₂	6.249	1	4 ⁵ / ₈	7	5 ³ / ₈	1 ¹ / ₂	1 ¹ / ₂	7	2 ¹ / ₄	3 ⁷ / ₁₆	5 ⁷ / ₈	7 ¹⁵ / ₁₆	7 ³ / ₈
	2 ¹ / ₂	2 ¹ / ₄ -12	1 ⁷ / ₈ -12	3	3.124	1	2 ¹ / ₁₆	4 ¹ / ₂	2 ³ / ₈	1 ¹ / ₂	1 ¹ / ₂	4	2 ¹ / ₄	3 ⁷ / ₁₆	5 ⁷ / ₈	7 ¹⁵ / ₁₆	7 ³ / ₈
	3	2 ³ / ₄ -12	2 ¹ / ₄ -12	3 ¹ / ₂	3.749	1	2 ⁵ / ₈	5	2 ⁷ / ₈	1 ¹ / ₂	1 ¹ / ₂	5 ¹ / ₂	2 ¹ / ₄	3 ⁷ / ₁₆	5 ⁷ / ₈	7 ¹⁵ / ₁₆	7 ³ / ₈
	3 ¹ / ₂	3 ¹ / ₄ -12	2 ¹ / ₂ -12	3 ¹ / ₂	4.249	1	3	5	3 ³ / ₈	1 ¹ / ₂	1 ¹ / ₂	5 ¹ / ₂	2 ¹ / ₄	3 ⁷ / ₁₆	5 ⁷ / ₈	7 ¹⁵ / ₁₆	7 ³ / ₈
	4	3 ³ / ₄ -12	3-12	4	4.749	1	3 ³ / ₈	5 ¹ / ₂	3 ⁷ / ₈	1 ¹ / ₂	1 ¹ / ₂	5 ¹ / ₂	2 ¹ / ₄	3 ⁷ / ₁₆	5 ⁷ / ₈	7 ¹⁵ / ₁₆	7 ³ / ₈
	1 ³ / ₈	1 ¹ / ₄ -12	1-14	1 ⁵ / ₈	1.999	5 ⁵ / ₈	1 ¹ / ₈	2 ¹ / ₂	1 ⁵ / ₁₆	1 ¹ / ₄	7 ⁷ / ₈	4	1 ⁵ / ₈	2 ¹³ / ₁₆	5 ¹ / ₄	7 ⁵ / ₁₆	6 ³ / ₄
	1 ³ / ₄	1 ¹ / ₂ -12	1 ¹ / ₄ -12	2	2.374	3 ³ / ₄	1 ¹ / ₂	3 ¹ / ₈	1 ¹¹ / ₁₆	3 ³ / ₈	1 ¹ / ₈	4	1 ⁷ / ₈	3 ¹ / ₁₆	5 ¹ / ₂	7 ⁹ / ₁₆	7
	4 ¹ / ₂	4 ¹ / ₄ -12	3 ¹ / ₄ -12	4 ¹ / ₂	5.249	1	3 ⁷ / ₈	6	4 ³ / ₈	1 ¹ / ₂	1 ¹ / ₂	7	2 ¹ / ₄	3 ⁷ / ₁₆	5 ⁷ / ₈	7 ¹⁵ / ₁₆	7 ³ / ₈
5	4 ³ / ₄ -12	3 ¹ / ₂ -12	5	5.749	1	4 ¹ / ₄	6 ¹ / ₂	4 ⁷ / ₈	1 ¹ / ₂	1 ¹ / ₂	7	2 ¹ / ₄	3 ⁷ / ₁₆	5 ⁷ / ₈	7 ¹⁵ / ₁₆	7 ³ / ₈	

Table 6 — Envelope and Mounting Dimensions

Side Lug Mount
Style MS2

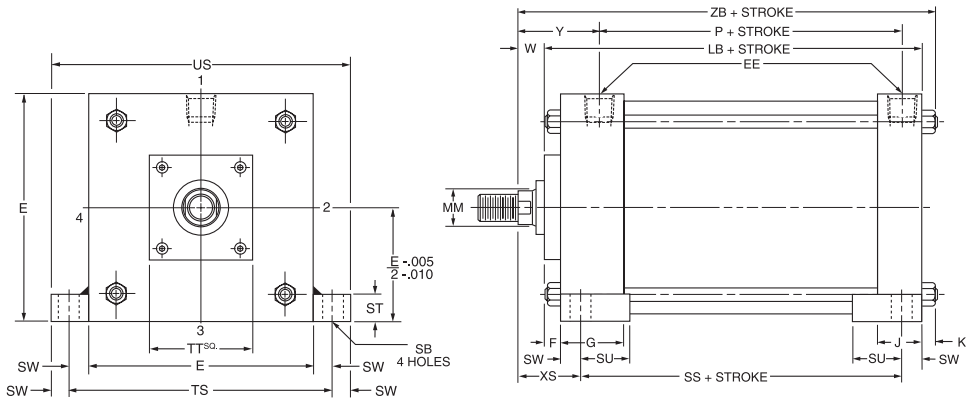
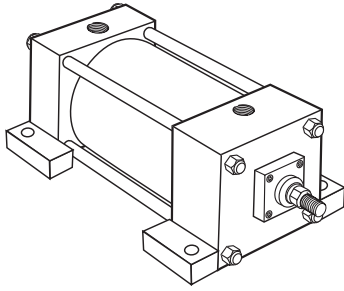

Side Tap Mount
Style MS4

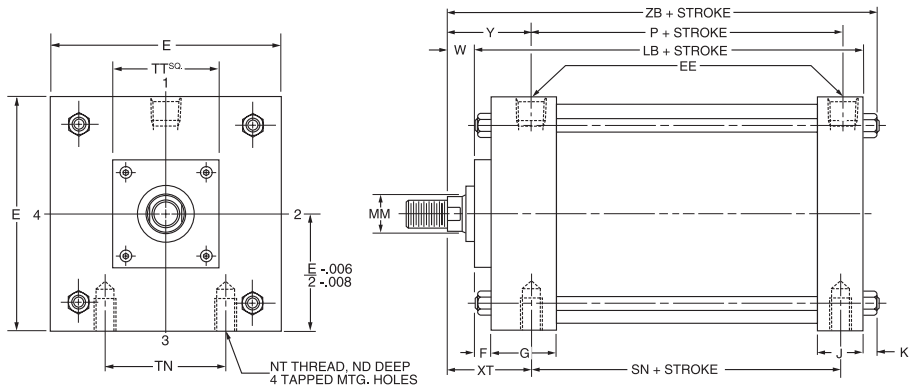
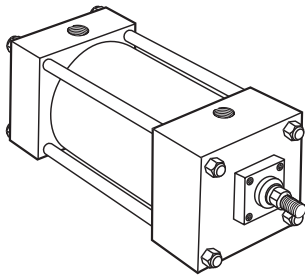

Rod End Dimensions — see table 2 or 5

Thread Style 2
Small Male

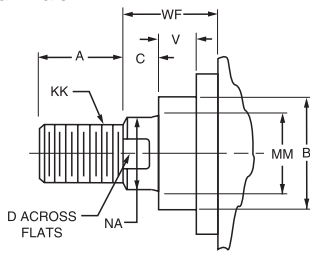

Thread Style 3
Short Female

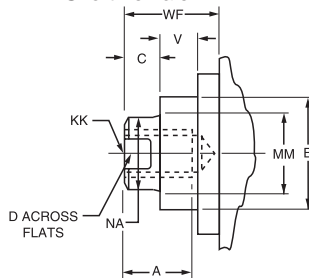

Thread Style 4
Intermediate Male

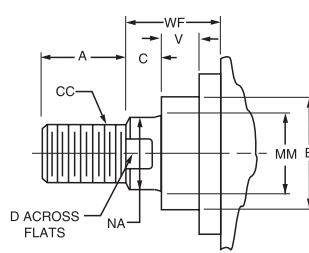

“Special” Thread Style 0

Special thread, extension, rod eye, blank, etc., are also available.

To order, specify “Style 0” and give desired dimensions for KK, A, W or WF. If otherwise special, furnish dimensioned sketch.

A high strength rod end stud is supplied on thread style 2 through 2" diameter rods. Larger sizes or special rod ends are cut threads. Style 2 rod ends are recommended where the workpiece is secured against the rod shoulder. When the workpiece is not shouldered, style 2 rod

ends are recommended through 2" piston rod diameters and style 4 rod ends are recommended on larger diameters. Use style 3 for applications where female rod end threads are required. If rod end is not specified, style 2 will be supplied.

Mounting Information – 8" Bore

Table 1—Envelope and Mounting Dimensions—Style MS2

Bore	E	EE		F	G	J	K	SB*	ST	SU	SW	TS	US	Add Stroke		
		NPTF [⊖]	SAE*											LB	P	SS
8	8 1/2	3/4	12	3/4	2	1 1/2	9/16	13/16	1	1 9/16	1 1/16	9 7/8	11 1/4	5 7/8	3 1/4	3 3/4

⊖ NPTF ports will be furnished as standard unless SAE straight thread ports are specified.

* SAE straight thread ports are indicated by port number.

• Upper surface spot-faced for socket-head screws.

Table 2—Rod End Dimensions—Style MS2

Bore	Rod Dia. MM	Thread		Rod Extensions and Pilot Dimensions								Add Stroke			
		Style 4 CC	Style 2 & 3 KK	A	+0.000 -0.002 B	C	D	LA	NA	V	W	TT	XS	Y	ZB
8	2	1 3/4-12	1 1/2-12	2 1/4	2.624	7/8	1 11/16	3 1/2	1 15/16	3/8	1 1/4	4	2 11/16	3 3/16	7 11/16
	5 1/2	5 1/4-12	4-12	5 1/2	6.249	1	4 5/8	7	5 3/8	1/2	1 1/2	7	2 15/16	3 7/16	7 15/16
	2 1/2	2 1/4-12	1 7/8-12	3	3.124	1	2 1/16	4 1/2	2 3/8	1/2	1 1/2	4	2 15/16	3 7/16	7 15/16
	3	2 3/4-12	2 1/4-12	3 1/2	3.749	1	2 5/8	5	2 7/8	1/2	1 1/2	5 1/2	2 15/16	3 7/16	7 15/16
	3 1/2	3 1/4-12	2 1/2-12	3 1/2	4.249	1	3	5	3 3/8	1/2	1 1/2	5 1/2	2 15/16	3 7/16	7 15/16
	4	3 3/4-12	3-12	4	4.749	1	3 3/8	5 1/2	3 7/8	1/2	1 1/2	5 1/2	2 15/16	3 7/16	7 15/16
	1 3/8	1 1/4-12	1-14	1 5/8	1.999	5/8	1 1/8	2 1/2	1 5/16	1/4	7/8	4	2 5/16	2 13/16	7 5/16
	1 3/4	1 1/2-12	1 1/4-12	2	2.374	3/4	1 1/2	3 1/8	1 11/16	3/8	1 1/8	4	2 5/16	3 1/16	7 9/16
	4 1/2	4 1/4-12	3 1/4-12	4 1/2	5.249	1	3 7/8	6	4 3/8	1/2	1 1/2	7	2 15/16	3 7/16	7 15/16
5	4 3/4-12	3 1/2-12	5	5.749	1	4 1/4	6 1/2	4 7/8	1/2	1 1/2	7	2 15/16	3 7/16	7 15/16	

Table 3 — Envelope and Mounting Dimensions

Table 4—Envelope and Mounting Dimensions—Style MS4

Bore	E	EE		F	G	J	K	ND	NT	TN	Add Stroke		
		NPTF [⊖]	SAE*								LB	P	SN
8	8 1/2	3/4	12	3/4	2	1 1/2	9/16	1 1/8	3/4-10	4 1/2	5 7/8	3 1/4	3 1/4

⊖ NPTF ports will be furnished as standard unless SAE straight thread ports are specified.

* SAE straight thread ports are indicated by port number.

Table 5—Rod End Dimensions—Style MS4

Bore	Rod Dia. MM	Thread		Rod Extensions and Pilot Dimensions								Add Stroke			
		Style 4 CC	Style 2 & 3 KK	A	+0.000 -0.002 B	C	D	LA	NA	V	W	TT	XT	Y	ZB
8	2	1 3/4-12	1 1/2-12	2 1/4	2.624	7/8	1 11/16	3 1/2	1 15/16	3/8	1 1/4	4	3 3/16	3 3/16	7 11/16
	5 1/2	5 1/4-12	4-12	5 1/2	6.249	1	4 5/8	7	5 3/8	1/2	1 1/2	7	3 7/16	3 7/16	7 15/16
	2 1/2	2 1/4-12	1 7/8-12	3	3.124	1	2 1/16	4 1/2	2 3/8	1/2	1 1/2	4	3 7/16	3 7/16	7 15/16
	3	2 3/4-12	2 1/4-12	3 1/2	3.749	1	2 5/8	5	2 7/8	1/2	1 1/2	5 1/2	3 7/16	3 7/16	7 15/16
	3 1/2	3 1/4-12	2 1/2-12	3 1/2	4.249	1	3	5	3 3/8	1/2	1 1/2	5 1/2	3 7/16	3 7/16	7 15/16
	4	3 3/4-12	3-12	4	4.749	1	3 3/8	5 1/2	3 7/8	1/2	1 1/2	5 1/2	3 7/16	3 7/16	7 15/16
	1 3/8	1 1/4-12	1-14	1 5/8	1.999	5/8	1 1/8	2 1/2	1 5/16	1/4	7/8	4	2 13/16	2 13/16	7 5/16
	1 3/4	1 1/2-12	1 1/4-12	2	2.374	3/4	1 1/2	3 1/8	1 11/16	3/8	1 1/8	4	3 1/16	3 1/16	7 9/16
	4 1/2	4 1/4-12	3 1/4-12	4 1/2	5.249	1	3 7/8	6	4 3/8	1/2	1 1/2	7	3 7/16	3 7/16	7 15/16
5	4 3/4-12	3 1/2-12	5	5.749	1	4 1/4	6 1/2	4 7/8	1/2	1 1/2	7	3 7/16	3 7/16	7 15/16	

Table 6 — Envelope and Mounting Dimensions

Cap Fixed Clevis Mount
Style MP1

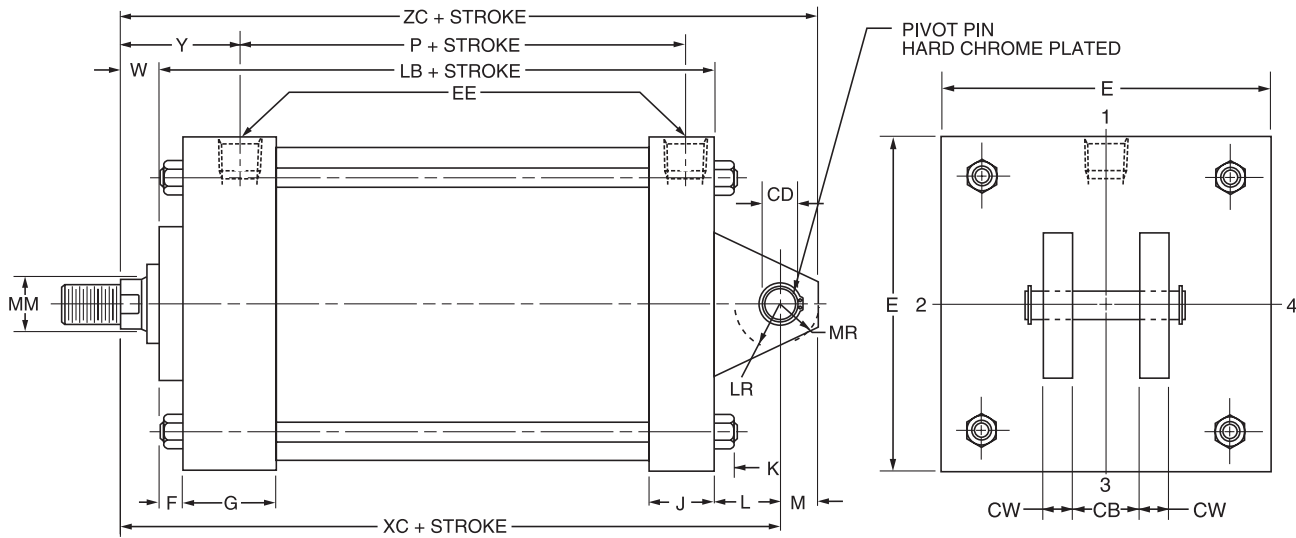
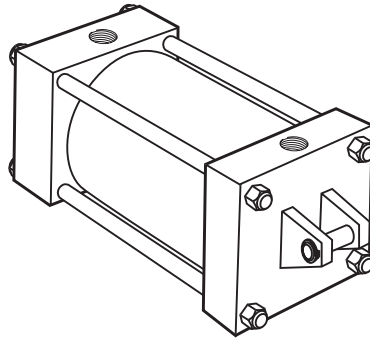

Rod End Dimensions — see table 2

Thread Style 2

Small Male

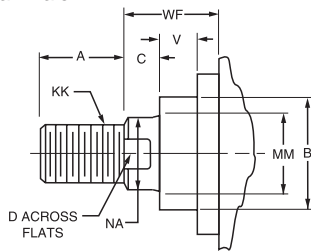

Thread Style 3

Short Female

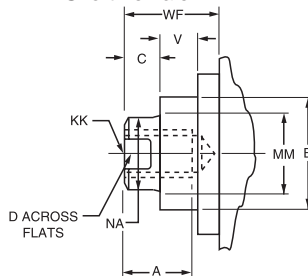

Thread Style 4

Intermediate Male

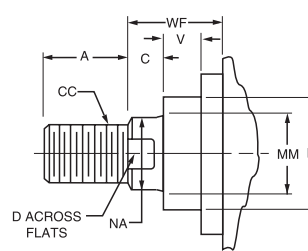

“Special” Thread Style 0

Special thread, extension, rod eye, blank, etc., are also available.

To order, specify “Style 0” and give desired dimensions for KK, A, W or WF. If otherwise special, furnish dimensioned sketch.

A high strength rod end stud is supplied on thread style 2 through 2" diameter rods. Larger sizes or special rod ends are cut threads. Style 2 rod ends are recommended where the workpiece is secured against the rod shoulder. When the workpiece is not shouldered, style 2 rod

ends are recommended through 2" piston rod diameters and style 4 rod ends are recommended on larger diameters. Use style 3 for applications where female rod end threads are required. If rod end is not specified, style 2 will be supplied.

Mounting Information – 8" Bore

Table 1—Envelope and Mounting Dimensions—Style MP1

Bore	CB	+0.000 -0.002 CD*	CW	E	EE		F	G	J	K	L	LR	M	MR	Add Stroke	
					NPTF [⊖]	SAE*									LB	P
8	1 1/2	1.001	3/4	8 1/2	3/4	12	3/4	2	1 1/2	9/16	1 1/2	1 1/4	1	1 3/16	5 7/8	3 1/4

- ⊖ NPTF ports will be furnished as standard unless SAE straight thread ports are specified.
- * SAE straight thread ports are indicated by port number.
- Dimension CD is pin diameter.

Table 2—Rod End Dimensions—Style MP1

Bore	Rod Dia. MM	Thread		Rod Extensions and Pilot Dimensions								Add Stroke		
		Style 4 CC	Style 2 & 3 KK	A	+0.000 -0.002 B	C	D	LA	NA	V	W	Y	XC	ZC
8	2	1 3/4-12	1 1/2-12	2 1/4	2.624	7/8	1 11/16	3 1/2	1 15/16	3/8	1 1/4	3 3/16	8 5/8	9 5/8
	5 1/2	5 1/4-12	4-12	5 1/2	6.249	1	4 5/8	7	5 3/8	1/2	1 1/2	3 7/16	8 7/8	9 7/8
	2 1/2	2 1/4-12	1 7/8-12	3	3.124	1	2 1/16	4 1/2	2 3/8	1/2	1 1/2	3 7/16	8 7/8	9 7/8
	3	2 3/4-12	2 1/4-12	3 1/2	3.749	1	2 5/8	5	2 7/8	1/2	1 1/2	3 7/16	8 7/8	9 7/8
	3 1/2	3 1/4-12	2 1/2-12	3 1/2	4.249	1	3	5	3 3/8	1/2	1 1/2	3 7/16	8 7/8	9 7/8
	4	3 3/4-12	3-12	4	4.749	1	3 3/8	5 1/2	3 7/8	1/2	1 1/2	3 7/16	8 7/8	9 7/8
	1 3/8	1 1/4-12	1-14	1 5/8	1.999	5/8	1 1/8	2 1/2	1 5/16	1/4	7/8	2 13/16	8 1/4	9 1/4
	1 3/4	1 1/2-12	1 1/4-12	2	2.374	3/4	1 1/2	3 1/8	1 11/16	3/8	1 1/8	3 1/16	8 1/2	9 1/2
	4 1/2	4 1/4-12	3 3/4-12	4 1/2	5.249	1	3 7/8	6	4 3/8	1/2	1 1/2	3 7/16	8 7/8	9 7/8
5	4 3/4-12	3 1/2-12	5	5.749	1	4 1/4	6 1/2	4 7/8	1/2	1 1/2	3 7/16	8 7/8	9 7/8	

Table 3 — Envelope and Mounting Dimensions

B

PL-2
PH-2
PH-3
PHX
SHM
CHE/CHD

**Head Trunnion Mount
Style MT1**

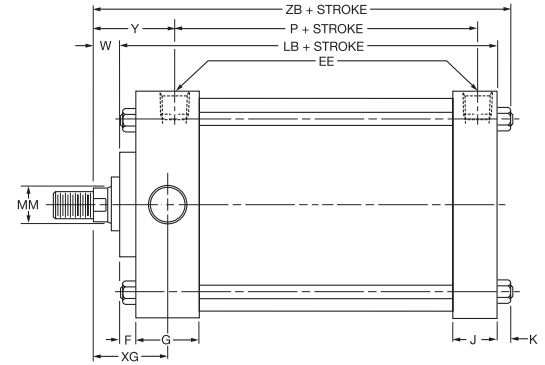
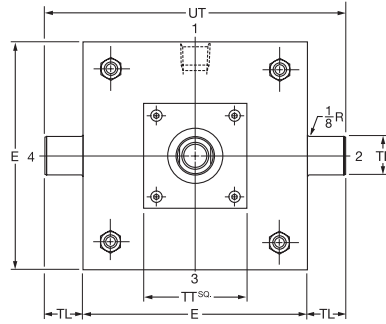
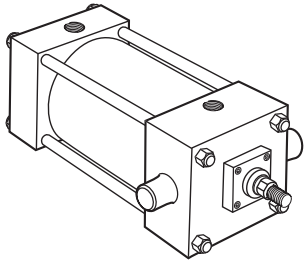

**Cap Trunnion Mount
Style MT2**

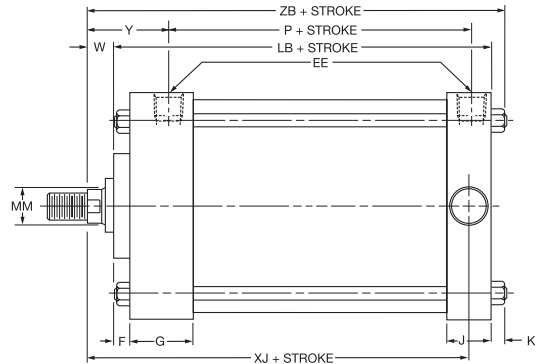
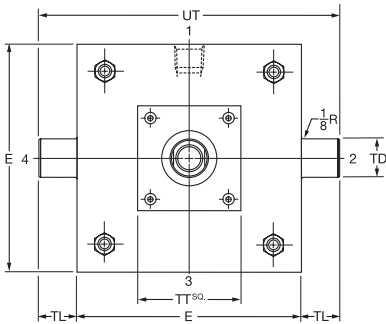
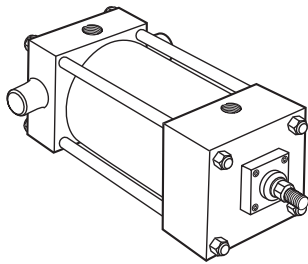

**Intermediate Fixed Trunnion Mount
Style MT4**

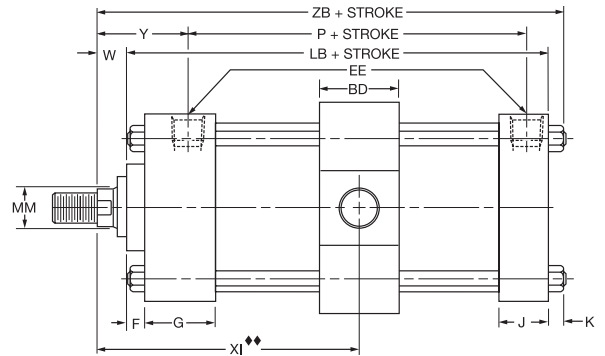
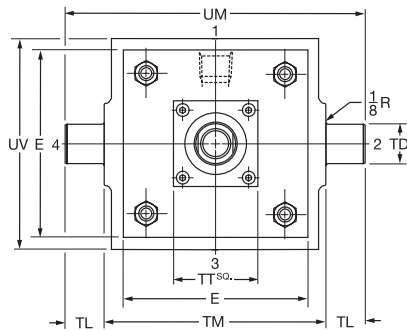
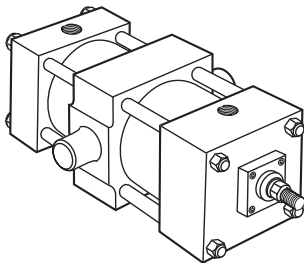

♦♦Dimension XI to be specified by customer.

Rod End Dimensions — see table 2 or 5

**Thread Style 2
Small Male**

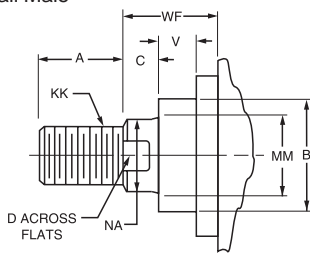

**Thread Style 3
Short Female**

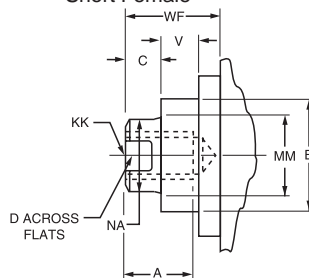

**Thread Style 4
Intermediate Male**

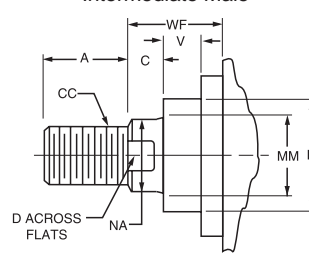

**“Special”
Thread Style 0**

Special thread, extension, rod eye, blank, etc., are also available.

To order, specify “Style 0” and give desired dimensions for KK, A, W or WF. If otherwise special, furnish dimensioned sketch.

A high strength rod end stud is supplied on thread style 2 through 2" diameter rods. Larger sizes or special rod ends are cut threads. Style 2 rod ends are recommended where the workpiece is secured against the rod shoulder. When the workpiece is not shouldered, style 2 rod

ends are recommended through 2" piston rod diameters and style 4 rod ends are recommended on larger diameters. Use style 3 for applications where female rod end threads are required. If rod end is not specified, style 2 will be supplied.

Mounting Information – 8" Bore

Table 1—Envelope and Mounting Dimensions—Styles MT1 and MT2

Bore	E	EE		F	G	J	K	+.000 -.001 TD	TL	UT	Add Stroke	
		NPTF [⊖]	SAE*								LB	P
8	8 1/2	3/4	12	3/4	2	1 1/2	9/16	1.375	1 3/8	11 1/4	5 7/8	3 1/4

⊖ NPTF ports will be furnished as standard unless SAE straight thread ports are specified.
* SAE straight thread ports are indicated by port number.

Table 2—Rod End Dimensions—Styles MT1 and MT2

Bore	Rod Dia. MM	Thread		Rod Extensions and Pilot Dimensions								Add Stroke				
		Style 4 CC	Style 2 & 3 KK	A	+.000 -.002 B	C	D	LA	NA	V	W	TT	XG	Y	XJ	ZB
8	2	1 3/4-12	1 1/2-12	2 1/4	2.624	7/8	1 11/16	3 1/2	1 15/16	3/8	1 1/4	4	3	3 3/16	6 3/8	7 11/16
	5 1/2	5 1/4-12	4-12	5 1/2	6.249	1	4 5/8	7	5 3/8	1 1/2	1 1/2	7	3 1/4	3 7/16	6 5/8	7 15/16
	2 1/2	2 1/4-12	1 7/8-12	3	3.124	1	2 1/16	4 1/2	2 3/8	1 1/2	1 1/2	4	3 1/4	3 7/16	6 5/8	7 15/16
	3	2 3/4-12	2 1/4-12	3 1/2	3.749	1	2 5/8	5	2 7/8	1 1/2	1 1/2	5 1/2	3 1/4	3 7/16	6 5/8	7 15/16
	3 1/2	3 1/4-12	2 1/2-12	3 1/2	4.249	1	3	5	3 3/8	1 1/2	1 1/2	5 1/2	3 1/4	3 7/16	6 5/8	7 15/16
	4	3 3/4-12	3-12	4	4.749	1	3 3/8	5 1/2	3 7/8	1 1/2	1 1/2	5 1/2	3 1/4	3 7/16	6 5/8	7 15/16
	1 3/8	1 1/4-12	1-14	1 5/8	1.999	5/8	1 1/8	2 1/2	1 5/16	1/4	7/8	4	2 5/8	2 13/16	6	7 5/16
	1 3/4	1 1/2-12	1 1/4-12	2	2.374	3/4	1 1/2	3 1/8	1 11/16	3/8	1 1/8	4	2 7/8	3 1/16	6 1/4	7 9/16
	4 1/2	4 1/4-12	3 1/4-12	4 1/2	5.249	1	3 7/8	6	4 3/8	1 1/2	1 1/2	7	3 1/4	3 7/16	6 5/8	7 15/16
5	4 3/4-12	3 1/2-12	5	5.749	1	4 1/4	6 1/2	4 7/8	1 1/2	1 1/2	7	3 1/4	3 7/16	6 5/8	7 15/16	

Table 3—Envelope and Mounting Dimensions

Table 4—Envelope and Mounting Dimensions—Style MT4

Bore	BD	E	EE		F	G	J	K	+.000 -.001 TD	TL	TM	UM	UV	Add Stroke		Style DD Min. Stroke
			NPTF [⊖]	SAE*										LB	P	
8	2 1/2	8 1/2	3/4	12	3/4	2	1 1/2	9/16	1.375	1 3/8	9 3/4	12 1/2	9 1/2	5 7/8	3 1/4	7/8

⊖ NPTF ports will be furnished as standard unless SAE straight thread ports are specified.
* SAE straight thread ports are indicated by port number.

Table 5—Rod End Dimensions—Style MT4

Bore	Rod Dia. MM	Thread		Rod Extensions and Pilot Dimensions								Add Stroke			
		Style 4 CC	Style 2 & 3 KK	A	+.000 -.002 B	C	D	LA	NA	V	W	TT	Min. XI	Y	ZB
8	2	1 3/4-12	1 1/2-12	2 1/4	2.624	7/8	1 11/16	3 1/2	1 15/16	3/8	1 1/4	4	5 5/16	3 3/16	7 11/16
	5 1/2	5 1/4-12	4-12	5 1/2	6.249	1	4 5/8	7	5 3/8	1 1/2	1 1/2	7	5 9/16	3 7/16	7 15/16
	2 1/2	2 1/4-12	1 7/8-12	3	3.124	1	2 1/16	4 1/2	2 3/8	1 1/2	1 1/2	4	5 9/16	3 7/16	7 15/16
	3	2 3/4-12	2 1/4-12	3 1/2	3.749	1	2 5/8	5	2 7/8	1 1/2	1 1/2	5 1/2	5 9/16	3 7/16	7 15/16
	3 1/2	3 1/4-12	2 1/4-12	3 1/2	4.249	1	3	5	3 3/8	1 1/2	1 1/2	5 1/2	5 9/16	3 7/16	7 15/16
	4	3 3/4-12	3-12	4	4.749	1	3 3/8	5 1/2	3 7/8	1 1/2	1 1/2	5 1/2	5 9/16	3 7/16	7 15/16
	1 3/8	1 1/4-12	1-14	1 5/8	1.999	5/8	1 1/8	2 1/2	1 5/16	1/4	7/8	4	4 15/16	2 13/16	7 5/16
	1 3/4	1 1/2-12	1 1/4-12	2	2.374	3/4	1 1/2	3 1/8	1 11/16	3/8	1 1/8	4	5 3/16	3 1/16	7 9/16
	4 1/2	4 1/4-12	3 1/4-12	4 1/2	5.249	1	3 7/8	6	4 3/8	1 1/2	1 1/2	7	5 9/16	3 7/16	7 15/16
5	4 3/4-12	3 1/2-12	5	5.749	1	4 1/4	6 1/2	4 7/8	1 1/2	1 1/2	7	5 9/16	3 7/16	7 15/16	

** Dimension XI to be specified by customer.

Spherical Bearing Mounting – Style MPU3

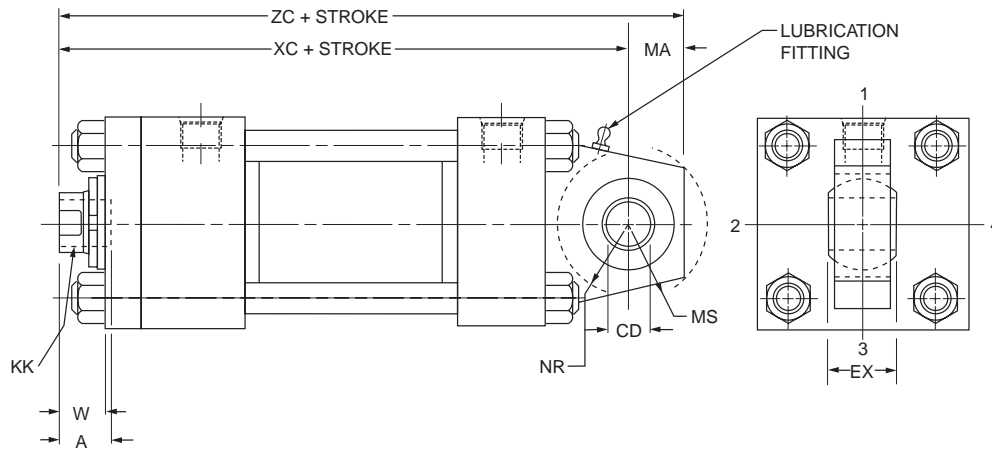

Table 1—Dimensions

Bore	Rod Dia. MM	Thread		A	CD ²	EX	MA	MS	NR	W	Add Stroke		Max. Oper. PSI ¹	
		Style 3 KK ³	Style 7 KK ³								XC	ZC		
1½	5/8	7/16-20	—	3/4	-.0005 .5000	7/16	3/4	15/16	5/8	5/8	5 3/8	6 1/8	1500	
	1	—	7/16-20	3/4							5 3/4	6 1/2		
2	5/8	7/16-20	—	3/4	-.0005 .5000	7/16	3/4	15/16	5/8	5/8	5 3/8	6 1/8	980	
	1 3/8	—	7/16-20	3/4							1 1/4	6		6 3/4
	1	—	7/16-20	3/4							1	5 3/4		6 1/2
2½	5/8	7/16-20	—	3/4	-.0005 .5000	7/16	3/4	15/16	5/8	5/8	5 1/2	6 1/4	630	
	1 3/4	—	7/16-20	3/4							1 1/2	6 3/8		7 1/8
	1	—	7/16-20	3/4							1	5 7/8		6 5/8
	1 3/8	—	7/16-20	3/4							1 1/4	6 1/8		6 7/8
3¼	1	3/4-16	—	1 1/8	-.0005 .7500	2 1/32	1	1 3/8	1	3/4	6 7/8	7 7/8	830	
	2	—	3/4-16	1 1/8							1 3/8	7 1/2		8 1/2
	1 3/8	—	3/4-16	1 1/8							1	7 1/8		8 1/8
	1 3/4	—	3/4-16	1 1/8							1 1/4	7 3/8		8 3/8
4	1	3/4-16	—	1 1/8	-.0005 .7500	2 1/32	1	1 3/8	1	3/4	6 7/8	7 7/8	550	
	2 1/2	—	3/4-16	1 1/8							1 5/8	7 3/4		8 3/4
	1 3/8	—	3/4-16	1 1/8							1	7 1/8		8 1/8
	1 3/4	—	3/4-16	1 1/8							1 1/4	7 3/8		8 3/8
	2	—	3/4-16	1 1/8							1 3/8	7 1/2		8 1/2
5	1	3/4-16	—	1 1/8	-.0005 .7500	2 1/32	1	1 3/8	1	3/4	7 1/8	8 1/8	350	
	3 1/2	—	3/4-16	1 1/8							1 5/8	8		9
	1 3/8	—	3/4-16	1 1/8							1	7 3/8		8 3/8
	1 3/4	—	3/4-16	1 1/8							1 1/4	7 5/8		8 5/8
	2	—	3/4-16	1 1/8							1 3/8	7 3/4		8 3/4
	2 1/2	—	3/4-16	1 1/8							1 5/8	8		9
	3	—	3/4-16	1 1/8							1 5/8	8		9
6	1 3/8	1-14	—	1 5/8	-.0005 1.0000	7/8	1 1/4	1 11/16	1 1/4	7/8	8 1/8	9 3/8	440	
	4	—	1-14	1 5/8							1 1/2	8 3/4		10
	1 3/4	—	1-14	1 5/8							1 1/8	8 3/8		9 5/8
	2	—	1-14	1 5/8							1 1/4	8 1/2		9 3/4
	2 1/2	—	1-14	1 5/8							1 1/2	8 3/4		10
	3	—	1-14	1 5/8							1 1/2	8 3/4		10
	3 1/2	—	1-14	1 5/8							1 1/2	8 3/4		10

¹ Maximum operating pressure at 4:1 design factor is based on tensile strength of material. Pressure ratings are based on standard commercial bearing ratings.

² Dimension CD is hole diameter.

³ Threads listed are also for a spherical rod eye which match style 9 or style 7. The spherical rod eye pin diameter matches the cap pin and (if required) needs to be purchased separately; see PL-2 mounting accessories for detailed information.

Spherical Bearing Mounting – Style MPU3

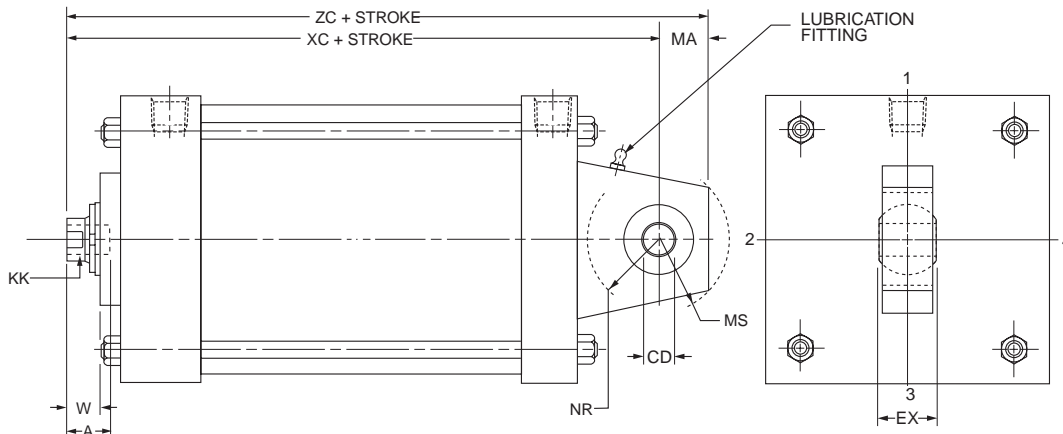

Table 1—Dimensions

Bore	Rod Dia. MM	Thread		A	CD ²	EX	MA	MS	NR	W	Add Stroke		Max. Oper. PSI ¹
		Style 3 KK ³	Style 7 KK ³								XC	ZC	
8	1 3/8	1-14	—	1 5/8	-0.0005 1.0000	7/8	1 1/4	1 1/16	1 1/4	7/8	9 1/2	9 1/2	250
	5 1/2	—	1-14	1 5/8						1 1/2	10 1/8	10 1/8	
	1 3/4	—	1-14	1 5/8						1 1/8	9 3/4	9 3/4	
	2	—	1-14	1 5/8						1 1/4	9 7/8	9 7/8	
	2 1/2	—	1-14	1 5/8						1 1/2	10 1/8	10 1/8	
	3	—	1-14	1 5/8						1 1/2	10 1/8	10 1/8	
	3 1/2	—	1-14	1 5/8						1 1/2	10 1/8	10 1/8	
	4	—	1-14	1 5/8						1 1/2	10 1/8	10 1/8	
	4 1/2	—	1-14	1 5/8						1 1/2	10 1/8	10 1/8	
5	—	1-14	1 5/8	1 1/2	10 1/8	10 1/8							

¹ Maximum operating pressure at 4:1 design factor is based on tensile strength of material. Pressure ratings are based on standard commercial bearing ratings.

² Dimension CD is hole diameter.

³ Threads listed are also for a spherical rod eye which match style 9 or style 7.

The spherical rod eye pin diameter matches the cap pin and (if required) needs to be purchased separately; see PL-2 mounting accessories for detailed information.

Mounting Information
Head End Mounting

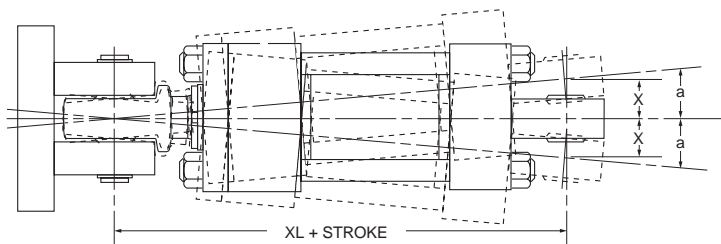

Recommended maximum swivel angle on each side of the cylinder centerline.

Bore	Head End Mounted		Cap End Mounted	
	Angle a	Tan. of a	Angle a	Tan. of a
1 1/2	2 1/2	.035	2 1/2	.035
2	2 1/2	.044	4 1/2	.079
2 1/2	2 1/2	.044	4 1/2	.079
3 1/4	3 1/2	.052	3 1/2	.052
4	2 1/2	.044	3 1/2	.052
5	3 1/2	.052	3 1/2	.052
6	3 1/2	.052	3 1/2	.052

Cap End Mounting

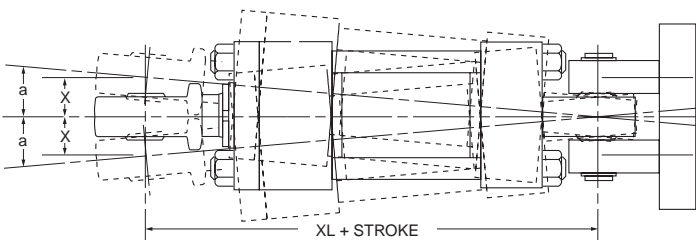

Note: Dimension X is the maximum off center mounting of the cylinder. To determine dimension X for various stroke lengths multiply the distance between pivot pin holes by tangent of angle a. For extended position use X = XL + 2X stroke.

Schrader Bellows offers a complete range of Cylinder Accessories to assure you of the greatest versatility in present or future cylinder applications. Accessories offered

for the respective cylinder include the Rod Eye, Pivot Pin and Clevis Bracket. To select the proper part number for any desired accessory refer to the charts below.

Spherical Rod Eye

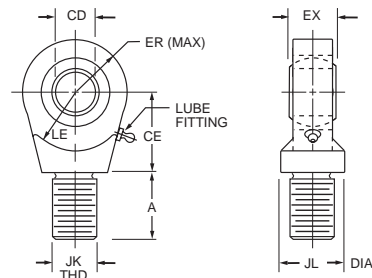

Order to fit Piston Rod Thread Size.

Bore Sizes	Series PL-2	1 1/2, 2 & 2 1/2	3 1/4, 4 & 5	6 & 8
Rod Eye	Part No.	1322900000	1322910000	1322920000
	CD	.5000 ^{-.0005}	.7500 ^{-.0005}	1.0000 ^{-.0005}
	A	1 1/16	1	1 1/2
	CE	7/8	1 1/4	1 7/8
	EX	7/16	2 1/32	7/8
	ER	1 3/16	1 1/8	1 1/4
	LE	3/4	1 1/16	1 7/16
	JK	7/16-20	3/4-16	1-14
	JL	7/8	1 5/16	1 1/2
	LOAD CAPACITY LBS.	2644	9441	16860

Pivot Pin

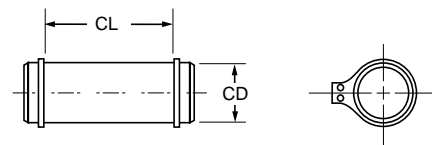

Pivot Pins are furnished with (2) Retainer Rings.

Bore Sizes	Series PL-2	1 1/2, 2 & 2 1/2	3 1/4, 4 & 5	6 & 8
Pivot Pin	Part No.	0839620000	0839630000	0839640000
	CD	.4997 ^{-.0004}	.7497 ^{-.0005}	.9997 ^{-.0005}
	CL	1 9/16	2 1/32	2 1/2
	LOAD CAPACITY LBS.	8600	19300	34300

Clevis Bracket

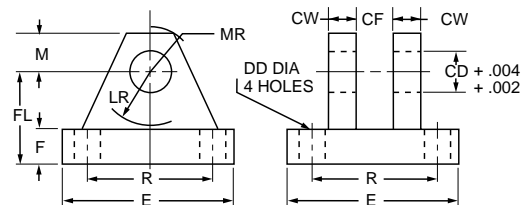

Order to fit Cap or Rod Eye.

Bore Sizes	Series PL-2	1 1/2, 2 & 2 1/2	3 1/4, 4 & 5	6 & 8
Clevis Bracket	Part No.	0839470000	0839480000	0839490000
	CD	1/2	3/4	1
	CF	7/16	2 1/32	7/8
	CW	1/2	5/8	3/4
	DD	1 3/32	1 7/32	1 7/32
	E	3	3 3/4	5 1/2
	F	1/2	5/8	3/4
	FL	1 1/2	2	2 1/2
	LR	1 5/16	1 3/8	1 11/16
	M	1/2	7/8	1
	MR	5/8	1	1 3/16
	R	2.05	2.76	4.10
	LOAD CAPACITY LBS.	5770	9450	14300

To determine dimensions for a double rod cylinder, first refer to the desired single rod mounting style cylinder shown on preceding pages of this catalog. After selecting necessary dimensions from that drawing, return to this page and supplement the single rod dimensions with those shown below. Note that double rod cylinders have a head (Dim. G) at both ends and that dimension LD or LF replaces LB or LG. The double rod dimensions differ from, or are in addition to those for single rod cylinders shown on preceding pages and provide the information needed to completely dimension a double rod cylinder. On a double rod cylinder where the two ends are different, be sure to clearly state which rod end is to be assembled at which end.

Port position 1 is standard. If other than standard, specify position 2, 3 or 4 when viewed from one end only.

If only one end of these Double Rod Cylinders is to be cushioned, be sure to specify clearly which end this will be.

Specify XI dimension from rod end #1.

**How to Use Double Rod Cylinder Dimension Drawings
1" to 6" Bores**

Tie Rod Retained Cartridge

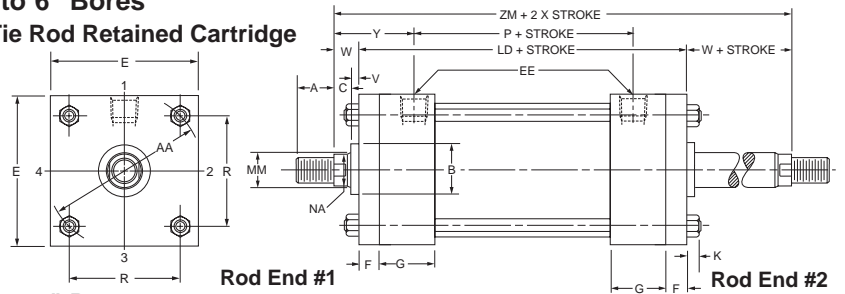

1" to 6" Bores

Removable Cartridge

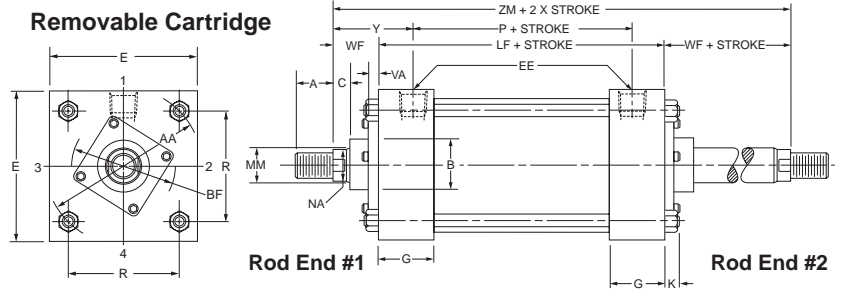

8" Bores

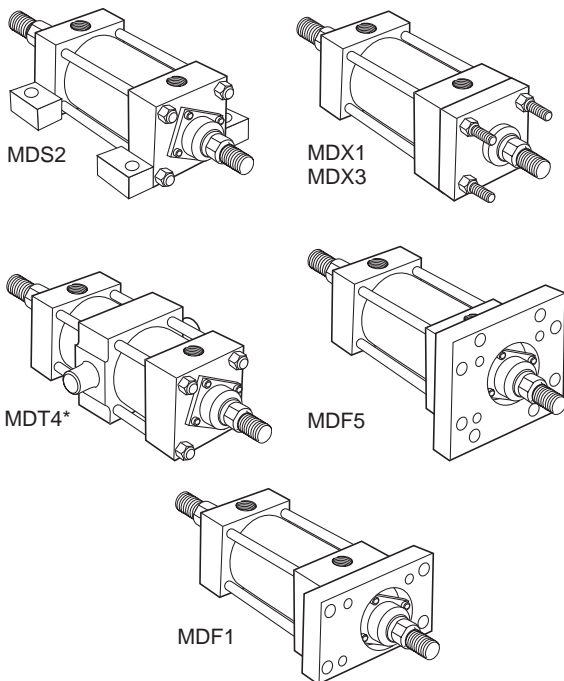
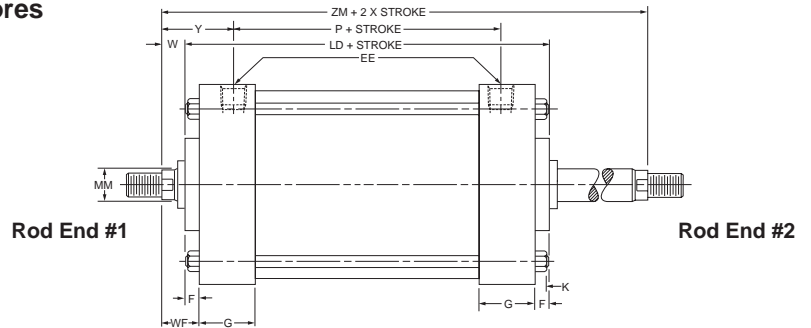

All dimensions are in inches and apply to standard rod sizes only. For alternate rod sizes, determine all envelope dimensions (within LD dim.) as described above and then use appropriate rod end dimensions for proper rod size from single rod cylinder.

Bore	Rod Dia. MM	Add Stroke			Add 2X Stroke
		LD	LF	SS	ZM
1	1/2	4 3/4	4 1/8	3 3/8	6
1 1/2	5/8	4 7/8	4 1/8	3 3/8	6 1/8
2	5/8	4 7/8	4 1/8	3 3/8	6 1/8
2 1/2	1	5	4 1/4	3 1/2	7
3 1/4	1	6	4 3/4	3 3/4	7 1/2
4	1 3/8	6	4 3/4	3 3/4	8
5	1 3/4	6 1/4	5	3 5/8	8 3/4
6	1 3/4	7	5 1/2	4 1/8	9 1/4
8	2	7 1/8	5 5/8	4 1/4	9 5/8
Replaces:		LB	LG	SA	—
On single rod mounting styles:		All Mtg. Styles		MS2	All Mtgs.

*Mounting style MDT4 not available in 1" bore size.

Cylinder Accessories

Schrader Bellows offers a complete range of cylinder accessories to assure you of the greatest versatility in present and future cylinder applications.

Rod End Accessories

Accessories offered for the rod end of the cylinder include Rod Clevis, Eye Bracket, Knuckle, Clevis Bracket, and Pivot Pin. To select the proper part number for any desired accessory, refer to the table below or on the opposite page and look in the row to the right of the rod thread in the first column. For economical accessory selection, it is recommended that rod end style 2 be specified on your cylinder order.

Accessory Load Capacity

The various accessories have been load rated for your convenience. The load Capacity in lbs. Is the recommended maximum load for that accessory based on a 4:1 design factor in tension. (Pivot Pin is rated in shear.) Before specifying, compare the actual load or the tension (pull) force at maximum operating pressure of the cylinder with the load capacity of the accessory you plan to use. If load or pull force of cylinder exceeds load capacity of accessory, consult factory.

Thread Size	Rod Clevis		Mounting Plate or Eye Bracket		Pivot Pin	
	Part Number	Load Capacity (Lbs.)	Part Number	Load Capacity (Lbs.)	Part Number	Shear Capacity (Lbs.)
5/16-24	0512210000†	2600	0740770000	1700	—	—
7/16-20	0509400000	4250	0691950000	4100	0683680000	8600
1/2-20	0509410000	4900	0691950000	4100	0683680000	8600
3/4-16	0509420000	11200	0691960000	10500	0683690000	19300
3/4-16	1332840000	11200	0691960000	10500	0683690000	19300
7/8-14	0509430000	18800	*0853610000	20400	0683700000	34300
1-14	0509440000	19500	*0853610000	20400	0683700000	34300
1-14	1332850000	19500	*0853610000	20400	0683700000	34300
1 1/4-12	0509450000	33500	0691980000	21200	0683710000	65000
1 1/4-12	1332860000	33500	0691980000	21200	0683710000	65000
1 1/2-12	0509460000	45600	*0853620000	49480	0683720000	105200
1 3/4-12	0509470000	65600	*0853630000	70000	0683730000	137400
1 7/8-12	0509480000	65600	*0853630000	70000	0683730000	137400
2 1/4-12	0509490000	98200	*0853640000	94200	0683740000	214700
2 1/2-12	0509500000	98200	*0853650000	121900	0683750000	309200
2 3/4-12	0509510000	98200	*0853650000	121900	0683750000	309200
3 1/4-12	0509520000	156700	0735380000	57400	0735450000	420900
3 1/2-12	0509530000	193200	0735390000	75000	0735470000	565800
4-12	0509540000	221200	0735390000	75000	0735470000	565800

† Includes pivot pin.

* Cylinder accessory dimensions conform to NFPA recommended standard NFPA/T3.6.8 R1-1984, NFPA recommended standard fluid power systems – cylinder – dimensions for accessories for cataloged square head industrial cylinders.

Rod Clevis Dimensions

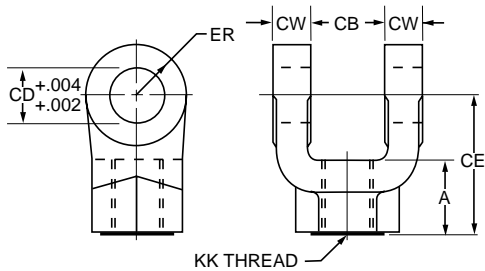

Pivot Pin Dimensions

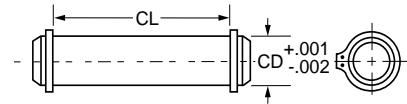

Part Number	A	CB	CD	CE	CW	ER	KK
0512210000†	13/16	11/32	5/16	2 1/4	13/64	19/64	5/16-24
0509400000	3/4	3/4	1/2	1 1/2	1/2	1/2	7/16-20
0509410000	3/4	3/4	1/2	1 1/2	1/2	1/2	1/2-20
0509420000	1 1/8	1 1/4	3/4	2 1/8	5/8	3/4	3/4-16
1332840000	1 1/8	1 1/4	3/4	2 3/8	5/8	3/4	3/4-16
0509430000	1 5/8	1 1/2	1	2 15/16	3/4	1	7/8-14
0509440000	1 5/8	1 1/2	1	2 15/16	3/4	1	1-14
1332850000	1 5/8	1 1/2	1	3 1/8	3/4	1	1-14
0509450000	1 7/8	2	1 3/8	3 3/4	1	1 3/8	1 1/4-12
1332860000	2	2	1 3/8	4 1/8	1	1 3/8	1 1/4-12
0509460000	2 1/4	2 1/2	1 3/4	4 1/2	1 1/4	1 3/4	1 1/2-12
0509470000	3	2 1/2	2	5 1/2	1 1/4	2	1 3/4-12
0509480000	3	2 1/2	2	5 1/2	1 1/4	2	1 7/8-12
0509490000	3 1/2	3	2 1/2	6 1/2	1 1/2	2 1/2	2 1/4-12
0509500000	3 1/2	3	3	6 3/4	1 1/2	2 3/4	2 1/2-12
0509510000	3 1/2	3	3	6 3/4	1 1/2	2 3/4	2 3/4-12
0509520000	3 1/2‡	4	3 1/2	7 3/4	2	3 1/2	3 1/4-12
0509530000	4‡	4 1/2	4	8 13/16	2 1/4	4	3 1/2-12
0509540000	4‡	4 1/2	4	8 13/16	2 1/4	4	4-12

Part Number	CD	CL
0683680000	1/2	1 7/8
0683690000	3/4	2 5/8
0683700000	1	3 1/8
0683710000	1 3/8	4 1/8
0683720000	1 3/4	5 3/16
0683730000	2	5 3/16
0683740000	2 1/2	6 3/16
0683750000	3	6 1/4
0735450000	3 1/2	8 1/4
0735470000*	4	9

- This size supplied with cotter pins.
- 1. Pivot Pins are furnished with Clevis Mounted Cylinders as standard.
- 2. Pivot Pins are furnished with (2) Retainer Rings.
- 3. Pivot Pins must be ordered as a separate item if to be used with Rod Eyes, Rod Clevises, or Clevis Brackets.

† Includes Pivot Pin

‡ Consult appropriate cylinder rod end dimensions for compatibility.

Mounting Plate or Eye Bracket Dimensions

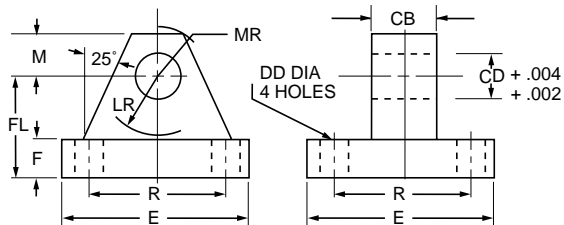

1. When used to mate with the Rod Clevis, select by thread size in table on opposite page.
2. When used to mount the Style MP1 Cylinders, select by bore size below.

Part Number	CB	CD	DD	E	F	FL	LR	M	MR	R	Bore
0740770000	5/16	5/16	17/64	2 1/4	3/8	1	5/8	3/8	1/2	1.75	1"
0691950000	3/4	1/2	13/32	2 1/2	3/8	1 1/8	3/4	1/2	9/16	1.63	1 1/2", 2", 2 1/2"
0691960000	1 1/4	3/4	17/32	3 1/2	5/8	1 7/8	1 1/4	3/4	7/8	2.55	3 1/4", 4", 5"
*0853610000	1 1/2	1	21/32	4 1/2	7/8	2 3/8	1 1/2	1	1 1/4	3.25	6", 8"
0691980000	2	1 3/8	21/32	5	7/8	3	2 1/8	1 3/8	1 5/8	3.82	—
*0853620000	2 1/2	1 3/4	29/32	6 1/2	1 1/8	3 3/8	2 1/4	1 3/4	2 1/8	4.95	—
*0853630000	2 1/2	2	1 1/16	7 1/2	1 1/2	4	2 1/2	2	2 7/16	5.73	—
*0853640000	3	2 1/2	1 3/16	8 1/2	1 3/4	4 3/4	3	2 1/2	3	6.58	—
*0853650000	3	3	1 5/16	9 1/2	2	5 1/4	3 1/4	2 3/4	3 1/4	7.50	—
0735380000	4	3 1/2	1 13/16	12 5/8	1 11/16	5 11/16	4	3 1/2	4 1/8	9.62	—
0735390000	4 1/2	4	2 1/16	14 7/8	1 15/16	6 7/16	4 1/2	4	5 1/4	11.45	—

* Cylinder accessory dimensions conform to NFPA recommended standard NFPA/T3.6.8 R1-1984, NFPA recommended standard fluid power systems – cylinder – dimensions for accessories for cataloged square head industrial cylinders.

Rod End Accessories

Accessories offered for the rod end of the cylinder include Rod Clevis, Eye Bracket, Knuckle, Clevis Bracket, and Pivot Pin. To select the proper part number for any desired accessory, refer to the table below or on the opposite page and look in the row to the right of the rod thread in the first column. For economical accessory selection, it is recommended that rod end style 2 be specified on your cylinder order.

Accessory Load Capacity

The various accessories have been load rated for your convenience. The load Capacity in lbs. is the recommended maximum load for that accessory based on a 4:1 design factor in tension. (Pivot Pin is rated in shear.) Before specifying, compare the actual load or the tension (pull) force at the maximum operating pressure of the cylinder with the load capacity of the accessory you plan to use. If load or pull force of cylinder exceeds load capacity of accessory, consult factory.

Thread Size	Knuckle		Clevis Bracket		Pivot Pin	
	Part Number	Load Capacity (Lbs.)	Part Number	Load Capacity (Lbs.)	Part Number	Shear Capacity (Lbs.)
5/16-24	0740750000	3300	0740760000	3600	0740780000	6600
7/16-20	0690890000	5000	0692050000	7300	0683680000	8600
1/2-20	0690900000	5700	0692050000	7300	0683680000	8600
3/4-16	0690910000	12100	0692060000	14000	0683690000	19300
3/4-16	0690910000	12100	0692060000	14000	0683690000	19300
7/8-14	0690920000	13000	0692070000	19200	0683700000	34300
1-14	0690930000	21700	0692070000	19200	0683700000	34300
1-14	0690930000	21700	0692070000	19200	0683700000	34300
1 1/4-12	0690940000	33500	0692080000	36900	0683710000	65000
1 1/4-12	0690940000	33500	0692080000	36900	0683710000	65000
1 1/2-12	0690950000	45000	0692090000	34000	0683720000	105200
1 3/4-12	0690960000	53500	0692100000	33000	0692150000	137400
1 7/8-12	0690970000	75000	0692100000	33000	0692150000	137400
2 1/4-12	0690980000	98700	0692110000	34900	0683740000	214700
2 1/2-12	0690990000	110000	0692120000	33800	0683750000	309200
2 3/4-12	0691000000	123300	0692130000	36900	0692160000	309200
3 1/4-12	0735360000	161300	0735420000	83500	0735450000	420900
3 1/2-12	0734370000	217300	0735420000	83500	0735450000	420900
4-12	0734380000	273800	0735430000	102600	0821810000	565800
4 1/2-12	0734390000	308500	0735440000	108400	0735470000•	565800

• This size supplied with cotter pins.

Knuckle Dimensions

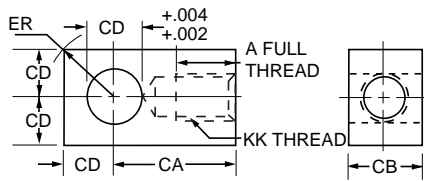

Pivot Pin Dimensions

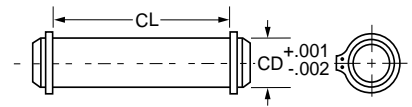

Part Number	A	CA	CB	CD	ER	KK
0740750000	3/4	1 1/2	7/16	7/16	19/32	5/16-24
0690890000	3/4	1 1/2	3/4	1/2	23/32	7/16-20
0690900000	3/4	1 1/2	3/4	1/2	23/32	1/2-20
0690910000	1 1/8	2 1/16	1 1/4	3/4	1 1/16	3/4-16
0690920000	1 1/8	2 3/8	1 1/2	1	1 7/16	7/8-14
0690930000	1 5/8	2 13/16	1 1/2	1	1 7/16	1-14
0690940000	2	3 7/16	2	1 3/8	1 31/32	1 1/4-12
0690950000	2 1/4	4	2 1/2	1 3/4	2 1/2	1 1/2-12
0690960000	2 1/4	4 3/8	2 1/2	2	2 27/32	1 3/4-12
0690970000	3	5	2 1/2	2	2 27/32	1 7/8-12
0690980000	3 1/2	5 13/16	3	2 1/2	3 9/16	2 1/4-12
0690990000	3 1/2	6 1/8	3	3	4 1/4	2 1/2-12
0691000000	3 5/8	6 1/2	3 1/2	3	4 1/4	2 3/4-12
0735360000	4 1/2	7 5/8	4	3 1/2	4 31/32	3 1/4-12
0734370000	5	7 5/8	4	3 1/2	4 31/32	3 1/2-12
0734380000	5 1/2	9 1/8	4 1/2	4	5 11/16	4-12
0734390000	5 1/2	9 1/8	5	4	5 11/16	4 1/2-12

Part Number	CD	CL
0740780000	7/16	1 5/16
0683680000	1/2	1 7/8
0683690000	3/4	2 5/8
0683700000	1	3 1/8
0683710000	1 3/8	4 1/8
0683720000	1 3/4	5 3/16
0692150000	2	5 11/16
0683740000	2 1/2	6 3/16
0683750000	3	6 1/4
0692160000	3	6 3/4
0735450000	3 1/2	8 1/4
0821810000	4	8 5/8
0735470000*	4	9

- * This size supplied with cotter pins.
1. Pivot Pins are furnished with Clevis Mounted Cylinders as standard.
 2. Pivot Pins are furnished with (2) Retainer Rings.
 3. Pivot Pins must be ordered as a separate item if to be used with Knuckles, Rod Clevises, or Clevis Brackets.

Clevis Bracket Dimensions

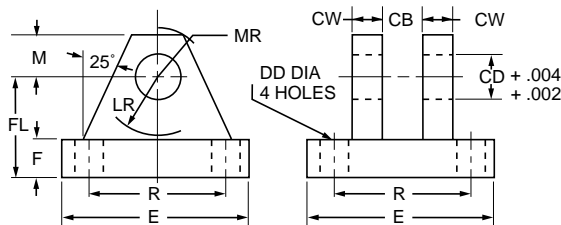

Part Number	CB	CD	CW	DD	E	F	FL	LR	M	MR	R
0740760000	15/32	7/16	3/8	17/64	2 1/4	3/8	1	5/8	3/8	1/2	1.75
0692050000	3/4	1/2	1/2	13/32	3 1/2	1/2	1 1/2	3/4	1/2	5/8	2.55
0692060000	1 1/4	3/4	5/8	17/32	5	5/8	1 7/8	1 3/16	3/4	29/32	3.82
0692070000	1 1/2	1	3/4	21/32	6 1/2	3/4	2 1/4	1 1/2	1	1 1/4	4.95
0692080000	2	1 3/8	1	21/32	7 1/2	7/8	3	2	1 3/8	1 21/32	5.73
0692090000	2 1/2	1 3/4	1 1/4	29/32	9 1/2	7/8	3 5/8	2 3/4	1 3/4	2 7/32	7.50
0692100000	2 1/2	2	1 1/2	1 1/16	12 3/4	1	4 1/4	3 3/16	2 1/4	2 25/32	9.40
0692110000	3	2 1/2	1 1/2	1 3/16	12 3/4	1	4 1/2	3 1/2	2 1/2	3 1/8	9.40
0692120000	3	3	1 1/2	1 5/16	12 3/4	1	6	4 1/4	3	3 19/32	9.40
0692130000	3 1/2	3	1 1/2	1 5/16	12 3/4	1	6	4 1/4	3	3 19/32	9.40
0735420000	4	3 1/2	2	1 13/16	15 1/2	1 11/16	6 11/16	5	3 1/2	4 1/8	12.00
0735430000	4 1/2	4	2	2 1/16	17 1/2	1 15/16	7 11/16	5 3/4	4	4 7/8	13.75
0735440000	5	4	2	2 1/16	17 1/2	1 15/16	7 11/16	5 3/4	4	4 7/8	13.75

Cylinder accessory dimensions conform to NFPA recommended standard NFPT/T3.6.8 R1-1984, NFPA recommended standard fluid power systems - cylinder - dimensions for accessories for cataloged square head industrial cylinders.

- * This size supplied with cotter pins.

B
 PL-2
 PH-2
 PH-3
 PHX
 SHM
 CHE/CHD

Schrader "Style 6" Piston Rod End

Rod end flange coupling for Series PL-2 Hydraulic Cylinders

- Simplifies alignment
- Reduces assembly time
- Allows full rated hydraulic pressure in push and pull directions
- Available in 5/8" through 5-1/2" piston rod diameters

Style 6 Rod End

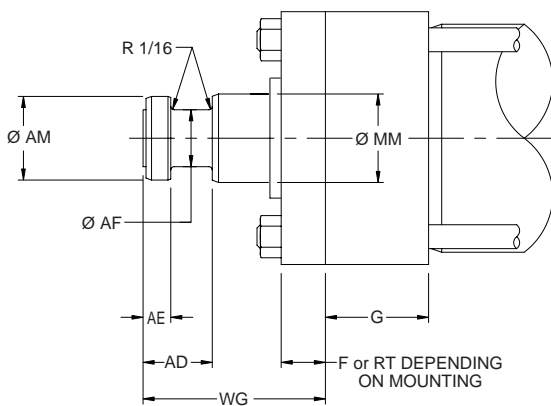

Dimensions Style 6 Rod End

MM Rod Dia.	AD	AE	AF	AM	WG
5/8	5/8	1/4	3/8	.57	1 3/4
1	1 5/16	3/8	1 1/16	.95	2 3/8
1 3/8	1 1/16	3/8	7/8	1.32	2 3/4
1 3/4	1 5/16	1/2	1 1/8	1.70	3 1/8
2	1 11/16	5/8	1 3/8	1.95	3 3/4
2 1/2	1 15/16	3/4	1 3/4	2.45	4 1/2
3	2 7/16	7/8	2 1/4	2.95	4 7/8
3 1/2	2 11/16	1	2 1/2	3.45	5 5/8
4	2 11/16	1	3	3.95	5 3/4
4 1/2	3 3/16	1 1/2	3 1/2	4.45	6 1/2
5	3 3/16	1 1/2	3 7/8	4.95	6 5/8
5 1/2	3 15/16	1 7/8	4 3/8	5.45	7 1/2

See Cylinder Catalog for F, G and RT per bore and series.

Consult Factory for availability of mounting accessories and Hardware.

How To Order

Complete Model Number and place a "6" in the Piston Rod End designator position.

Example: PLD113561X12.00

Schrader “Style 6” Piston Rod End

Split Couplers and Weld Plates

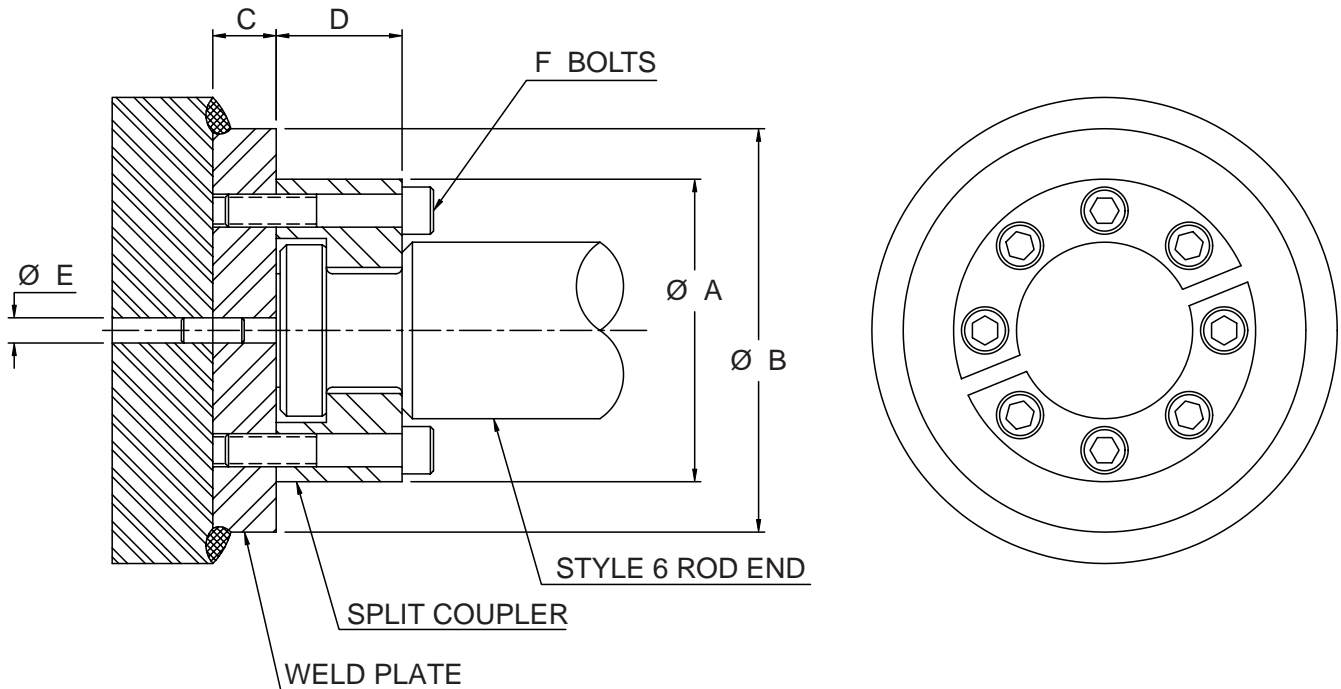

⚠ WARNING: Piston rod separation from the machine member can result in severe personal injury or even death to nearby personnel. The cylinder user must make sure the weld holding the weld plate to the machine is of sufficient quality and size to hold the intended load. The cylinder user must also make sure the bolts holding split coupler to the weld plate are of sufficient strength to hold the intended load and installed in such a way that they will not become loose during the machine's operation.

Table 1 — Part Numbers and Dimensions

Rod Dia.	A	B	C	D	E	F	Bolt Size	Bolt Circle	Split Coupler Part No.	Weld Plate Part No.
5/8	1.50	2.00	.50	.56	.250	4	#10-24 x .94 LG	1.125	1472340062	1481740062
1	2.00	2.50	.50	.88	.250	6	.250-20 x 1.25 LG	1.500	1472340100	1481740100
1 3/8	2.50	3.00	.63	1.00	.250	6	.312-18 x 1.50 LG	2.000	1472340138	1481740138
1 3/4	3.00	4.00	.63	1.25	.250	8	.312-18 x 1.75 LG	2.375	1472340175	1481740175
2	3.50	4.00	.75	1.63	.375	12	.375-16 x 2.25 LG	2.687	1472340200	1481740200
2 1/2	4.00	4.50	.75	1.88	.375	12	.375-16 x 2.50 LG	3.187	1472340250	1481740250
3	5.00	5.50	1.00	2.38	.375	12	.500-13 x 3.25 LG	4.000	1472340300	1481740300
3 1/2	5.88	7.00	1.00	2.63	.375	12	.625-11 x 3.50 LG	4.687	1472340350	1481740350
4	6.38	7.00	1.00	2.63	.375	12	.625-11 x 3.50 LG	5.187	1472340400	1481740400
4 1/2	6.88	8.00	1.00	3.13	.375	12	.625-11 x 4.00 LG	5.687	1472340450	1481740450
5	7.38	8.00	1.00	3.13	.375	12	.625-11 x 4.00 LG	6.187	1472340500	1481740500
5 1/2	8.25	9.00	1.25	3.88	.375	12	.750-10 x 5.00 LG	6.875	1472340550	1481740550

Note: Screws are not included with split coupler or weld plate.

B
 PH-2
 PH-3
 PHX
 SHM
 CHE/CHD

How to Order PL-2 Series Cylinders

When ordering PL-2 Series cylinders, please review the following:

Note: Duplicate cylinders can be ordered by giving the SERIAL NUMBER from the nameplate of the original cylinder. Factory records supply a quick positive identification.

Piston Rods: Specify model number code based on bore size and rod diameter. Give thread style number for a standard thread or specify dimensions. See "Style 0 Rod End" below.

Cushions: If cushions are required specify according to the model number on the next page. If the cylinder is to have a double rod and only one cushion is required, be sure to specify clearly which end of the cylinder is to be cushioned.

Special Modifications: Additional information is required on orders for cylinders with special modifications. This is best handled with descriptive notes. For further information, consult factory.

Lipseal™ Piston (if desired): Schrader Bellows Lipseal™ pistons are offered as an option at no extra cost in the Series PL-2 cylinders. With this feature, zero leakage under static holding conditions is attained.

Fluid Medium: Series PL-2 hydraulic cylinders are equipped with seals for use with hydraulic oil. If other than hydraulic oil will be used, specify class of fluid (See Catalog section C.)

See Section C for pressure ratings relating to bore and rod sizes.

Water Service Modifications

When requested, Schrader Bellows can supply Series PL-2 cylinders with standard modifications that make the cylinders suitable for use with water as the fluid medium. The modifications include chrome-plated cylinder bore; electroless nickel-plated, non-wearing internal surfaces; Lipseal style piston, Buna N Seals and chrome-plated, precipitation hardened stainless steel piston rod.

Warranty – Schrader Bellows will warrant Series PL-2 cylinders modified for water or high water content fluid service to be free of defects in materials or workmanship, but cannot accept responsibility for premature failure due to excessive wear resulting from lack of lubricity, where failure is caused by corrosion, electrolysis or mineral deposits within the cylinder.

Class 1 Seals

Class 1 seals are the seals provided as standard in a cylinder assembly unless otherwise specified. For further information on fluid compatibility or operating limitations of all components, see section C.

For the PL-2 series cylinders the following make-up Class 1 Seals:

Primary Piston Rod Seal – Enhanced Polyurethane

Piston Rod Wiper – Nitrile

Piston Seals – Nitrile lipseals with polymyte back-up washers

Option – Nitrile lipseals with polymyte back-up washers

O-Rings – Nitrile (nitrile back-up washer when used)

Style 0 Rod End

A style 0 rod end indicates a special rod end configuration. All special piston rod dimensions must have **all three:** KK; A; or W/WF specified with the rod fully retracted. A sketch or drawing should be submitted for rod ends requiring special machining such as snap ring grooves, keyways, tapers, multiple diameters, etc. It is good design practice to have this machining done on a diameter at least 0.065 inches smaller than the piston rod diameter. This allows the piston rod to have a chamfer preventing rod seal damage during assembly or maintenance.

Standard style 6 rod ends with a longer than standard WG dimension should call out a style 0 end and the note: **same as 6 except WG=_____**. A drawing should be submitted for special 6 rod ends that have specific tolerances or special radii. Special rod ends that have smaller than standard male threads, larger than standard female threads, or style 6 rod ends with smaller than standard AF or AE dimensions are to be reviewed by Engineering for proper strength at operating pressure.

Service Policy

On cylinders returned to the factory for repairs, it is standard policy for the Industrial Cylinder Division to make such part replacements as will put the cylinder in as good as new condition. Should the condition of the returned cylinder be such that expenses for repair would exceed the costs of a new one, you will be notified.

Address all correspondence and make shipments to, Service Department at your nearest regional plant.

Certified Dimensions

Schrader Bellows Industrial Cylinder Division guarantees that all cylinders ordered from this catalog will be built to dimensions shown. All dimensions are certified to be correct, and thus it is not necessary to request certified drawings.

How to Order

PL-2 Series

How To Order By Model Number

PL-2 Hydraulic Cylinders can be specified by model number by using the tables shown at right.

1. Type

Select the Model Number Code which identifies single or double end.

2. Bore & Rod Diameter

Select the Model Number Code which identifies the desired bore size and rod diameter combination.

3. Mounting & Cushioning

Select the Model Number Code which identifies the desired mounting style and cushioning option.

4. Rod End Style

Select the Model number Code which identifies the desired rod end thread style.

5. Seal Type

Complete the Model Number by selecting the type of seals desired. Piston rings optional, lip seals standard.

6. Stroke Length

It is necessary to specify the stroke length desired following the Model Number. For example: PLA100821 with 6" stroke.

Specifying the Desired Trunnion Location

For cylinders with intermediate trunnion mounting, the dimension specified should be the distance from the piston rod reference point to the center-line of the pin.

The Example Would Identify:

A single end hydraulic cylinder to be 1 1/2" bore size, 5/8" piston rod diameter, side lug mount, cushioned both ends, with a small male rod thread. Buna N Seals, and a 6" stroke.

Optional Mounting Accessories

Specify separately the part number for desired optional mounting accessories.

Note: For special modifications other than piston rod ends use S in the tenth position of the model number and describe special features required.
Example: PLA100821S 6" Stroke
 Ports to be in position # 2

1	Model Number
Type	PL-2 Series Hydraulic
Single End - NPT Ports	PL
Double End - NPT Ports	PM
Single End - SAE Ports	PE
Double End - SAE Ports	PG

2	Bore Size	Rod Dia.	Model Number Code	Bore Size	Rod Dia.	Model Number Code
	5"	1"	F11		1"	F11
		1 3/8"	F12		1 3/8"	F12
	1"	1 3/4"	F13		1 3/4"	F13
		5/8"	S10		2"	F14
		1"	A11		2 1/2"	F15
	1 1/2"	5/8"	A10		3"	F16
		1"	B10		3 1/2"	F17
	2"	5/8"	B11		6"	G12
		1"	B12		1 3/8"	G13
		1 3/8"	C10		1 3/4"	G14
	2 1/2"	5/8"	C11		2"	G15
		1"	C12		2 1/2"	G16
		1 3/8"	C13		3"	G17
		1 3/4"	D11		3 1/2"	G18
	3 1/4"	1"	D12		4"	J12
		1 3/8"	D13		4 1/2"	J13
		1 3/4"	D14		5"	J14
		2"	E11		5 1/2"	J15
	4"	1"	E12			J16
		1 3/8"	E13			J17
		1 3/4"	E14			J18
		2"	E15			J19
		2 1/2"				J41
						J42

3	Mounting Style	NFPA Style	Model Number Code			
			Non-Cush.	Cush. Head	Cush. Cap	Cush. Both
	Side Lug	MS2	05	06	07	08
	Side Tap	MS4	13	14	15	16
	Head Rectangular Flange (1-6)	MF1	21	22	23	24
	Cap Rectangular Flange (1-6)	MF2	25	26	27	28
	Head Square Flange (1-6)	MF5	29	30	31	32
	Cap Square Flange (1-6)	MF6	33	34	35	36
	Head Square (8)	ME3	37	38	39	40
	Cap Square (8)	ME4	41	42	43	44
	Tie Rods Extended Both Ends	MX1	53	54	55	56
	Tie Rods Extended Cap End	MX2	57	58	59	60
	Tie Rods Extended Head End	MX3	61	62	63	64
	Head Trunnion	MT1	69	70	71	72
	Cap Trunnion	MT2	73	74	75	76
	Intermediate Fixed Trunnion	MT4	77	78	79	80
	Cap Fixed Clevis	MP1	81	82	83	84
	Spherical Bearing	MPU3	89	90	91	92
	NO MOUNT	MX0	93	94	95	96

4 Rod End Style	Model Number Code
Small Male	2
Short Female	3
Intermediate Male	4
Flange Coupling	6
Female Thread for Spherical Rod Eye	7
Special - Specify	0

5 Seal Type	Model Number Code
Buna N Seals w/Lip Type Piston	1
Fluorocarbon Seals w/Lip Type Piston	2
Buna N Seals with Piston Rings	3
Fluorocarbon Seals with Piston Rings	4

Model Number Example:

PL A10 08 2 1 w/6" Stroke

Note on Seals: Cylinders ordered with Buna N Seals will have all soft seals from Buna N except piston rod seals which will be enhanced polyurethane. Backup washers for piston lipseals will be polymite. For further information on fluid compatibility and other seals see Section C.

6 Specify Stroke Length	6.00"
--------------------------------	-------



Linear Alignment Couplers are available in 12 standard thread sizes...

Cost Saving Features and Benefits Include:

- Maximum reliability for trouble-free operation, long life and lower operating costs
- Increased cylinder life by reducing wear on piston and rod bearings
- Simplified cylinder installation and reduced assembly costs
- Increased rod bearing and rod seal life for lower maintenance costs

Alignment Coupler

See Table 1 for Part Numbers and Dimensions

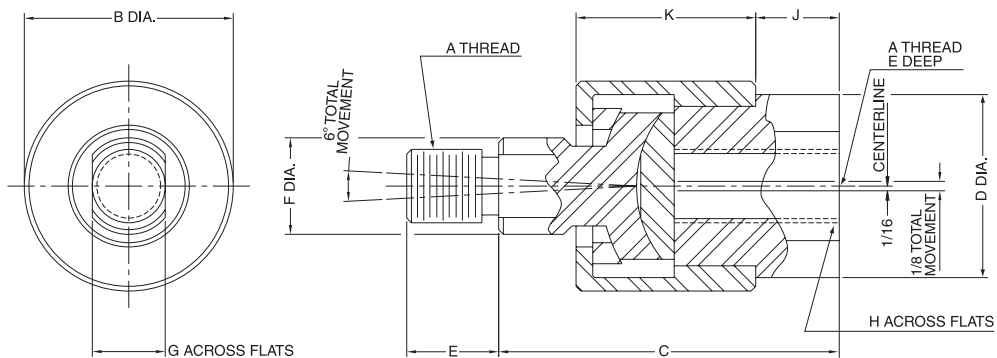

Table 1 — Part Numbers and Dimensions

Part No.	A	B	C	D	E	F	G	H	J	K	Max. Pull Load (lbs.)	Approx. Weight (lbs.)
1347570031	5/16-24	1 1/8	1 3/4	15/16	1/2	1/2	3/8	3/4	3/8	15/16	1200	.35
1347570038	3/8-24	1 1/8	1 3/4	15/16	1/2	1/2	3/8	3/4	3/8	15/16	2425	.35
1347570044	7/16-20	1 3/8	2	1 1/8	3/4	5/8	1/2	7/8	3/8	1 3/32	3250	.55
1347570050	1/2-20	1 3/8	2	1 1/8	3/4	5/8	1/2	7/8	3/8	1 3/32	4450	.55
1347570063	5/8-18	1 3/8	2	1 1/8	3/4	5/8	1/2	7/8	3/8	1 3/32	6800	.55
1347570075	3/4-16	2	2 5/16	1 5/8	1 1/8	15/16	3/4	1 5/16	7/16	1 9/32	9050	1.4
1347570088	7/8-14	2	2 5/16	1 5/8	1 1/8	15/16	3/4	1 5/16	7/16	1 9/32	14450	1.4
1347570100	1-14	3 1/8	3	2 3/8	1 5/8	1 7/16	1 1/4	1 7/8	3/4	1 25/32	19425	4.8
1347570125	1 1/4-12	3 1/8	3	2 3/8	1 5/8	1 7/16	1 1/4	1 7/8	3/4	1 25/32	30500	4.8
1337390125	1 1/4-12	3 1/2	4	2	2	1 1/2	1 1/4	1 11/16	3/4	2 1/2	30500	6.9
1337390150	1 1/2-12	4	4 3/8	2 1/4	2 1/4	1 3/4	1 1/2	1 15/16	7/8	2 3/4	45750	9.8
1337390175	1 3/4-12	4	4 3/8	2 1/4	2 1/4	1 3/4	1 1/2	1 15/16	7/8	2 3/4	58350	9.8
1337390188	1 7/8-12	5	5 5/8	3	3	2 1/4	1 15/16	2 5/8	1 3/8	3 3/8	67550	19.8

How to Order Linear Alignment Couplers — When ordering a cylinder with a threaded male rod end, specify the coupler of equal thread size by part number as listed in Table 1, i.e.; Piston Rod “KK” dimension is 3/4” - 16”, specify coupler part number 1347570075.



Contents

Features	50	Linear Alignment Couplers	69
Specifications and Mountings	51	Cylinder Accessories	70-73
Design Features.....	52-53	Style 6 Piston Rod End.....	74-75
Mounting Information	54-65	How to Order.....	76-77
Spherical Bearing Mounting.....	66-67	Parts I.D. and Seal Kits.....	Sec. C, pg. 44
Double Rod / Gland Retainer Style	68	Application Engineering Data	Sec. C, pgs. 49-85

Schrader Bellows PH-2 Series Heavy-Duty Hydraulic Cylinder

When the application demands a heavy-duty cylinder with maximum performance, specify Schrader Bellows PH-2 Series. This cylinder has standard design features to maximize machine uptime. The standard bronze rod gland, case-hardened piston rod, high strength piston rod stud and tie rod material combine to make the PH-2 Series the cylinder for demanding applications up to 3000 psi.

Thorough inspection and performance testing of each cylinder before shipment assure PH-2 Series cylinder quality. See the following pages for the inside story on all the features that make PH-2 Series the high performance, long lasting choice for all your heavy-duty hydraulic applications.



Standard Specifications

- Heavy Duty Service – ANSI/(NFPA) T3.6.7R2-1996 Mounting and Specification Dimensions
- Standard Construction – Square Head – Tie Rod Design
- Nominal Pressure – 3000 P.S.I.*
- Standard Fluid – Hydraulic Oil
- Standard Temperature – -10° F to +165° F
- Bore Sizes – 1½" through 6"
- Piston Rod Diameter – 5/8" through 4"
- Mounting Styles – 16 standard styles at various application ratings

- Standard – Externally removable bolted bushing assembly
- Strokes – Available in any practical stroke length
- Cushions – Optional at either end or both ends of stroke. "Float Check" at cap end.
- Rod Ends – Three Standard Choices – Specials to Order

* If hydraulic operating pressure exceeds 3000 P.S.I., send application data for engineering evaluation and recommendation. See Section C, Application Engineering Data for actual design factors.

In line with our policy of continuing product improvement, specifications in this catalog are subject to change.

Mounting Styles

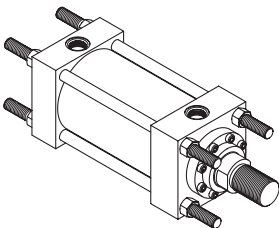
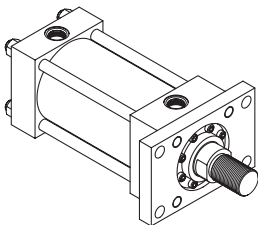
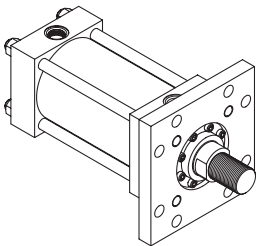
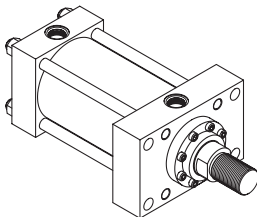
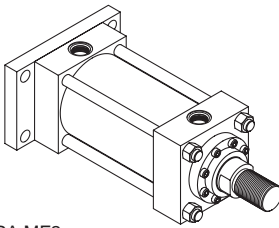
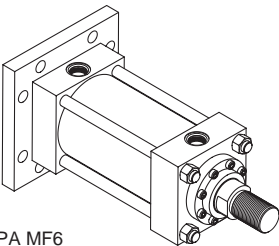
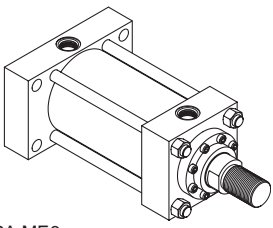
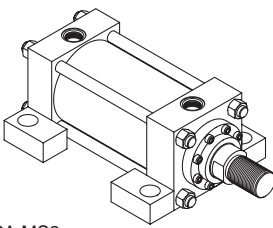
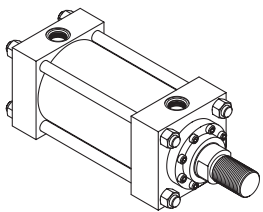
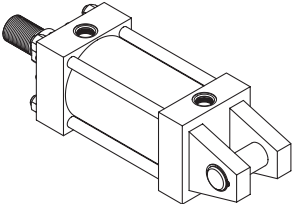
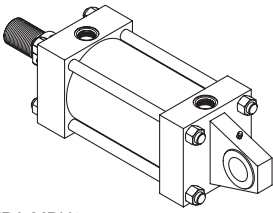
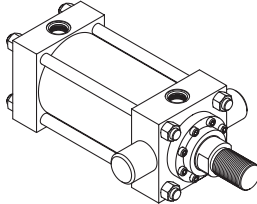
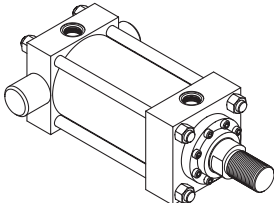
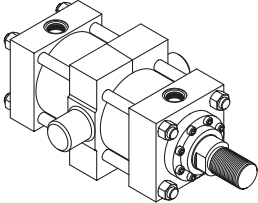
<p>Tie Rods Extended</p>  <p>BOTH ENDS NFPA MX1 CAP END NFPA MX2 HEAD END NFPA MX3</p>	<p>Head Rectangular Flange</p>  <p>NFPA MF1</p>	<p>Head Square Flange</p>  <p>NFPA MF5</p>	<p>Head Rectangular</p>  <p>NFPA ME5</p>
<p>Cap Rectangular Flange</p>  <p>NFPA MF2</p>	<p>Cap Square Flange</p>  <p>NFPA MF6</p>	<p>Cap Rectangular</p>  <p>NFPA ME6</p>	<p>Side Lug</p>  <p>NFPA MS2</p>
<p>Side Tap</p>  <p>NFPA MS4</p>	<p>Cap Fixed Clevis</p>  <p>NFPA MP1</p>	<p>Spherical Bearing</p>  <p>NFPA MPU3</p>	<p>Head Trunnion</p>  <p>NFPA MT1</p>
<p>Cap Trunnion</p>  <p>NFPA MT2</p>	<p>Intermediate Trunnion</p>  <p>NFPA MT4</p>		

B
PL-2
PH-2
PH-3
PHX
SHM
CHE/CHD

Schrader Bellows . . .

PH-2 Series – your best choice in heavy duty hydraulic cylinders

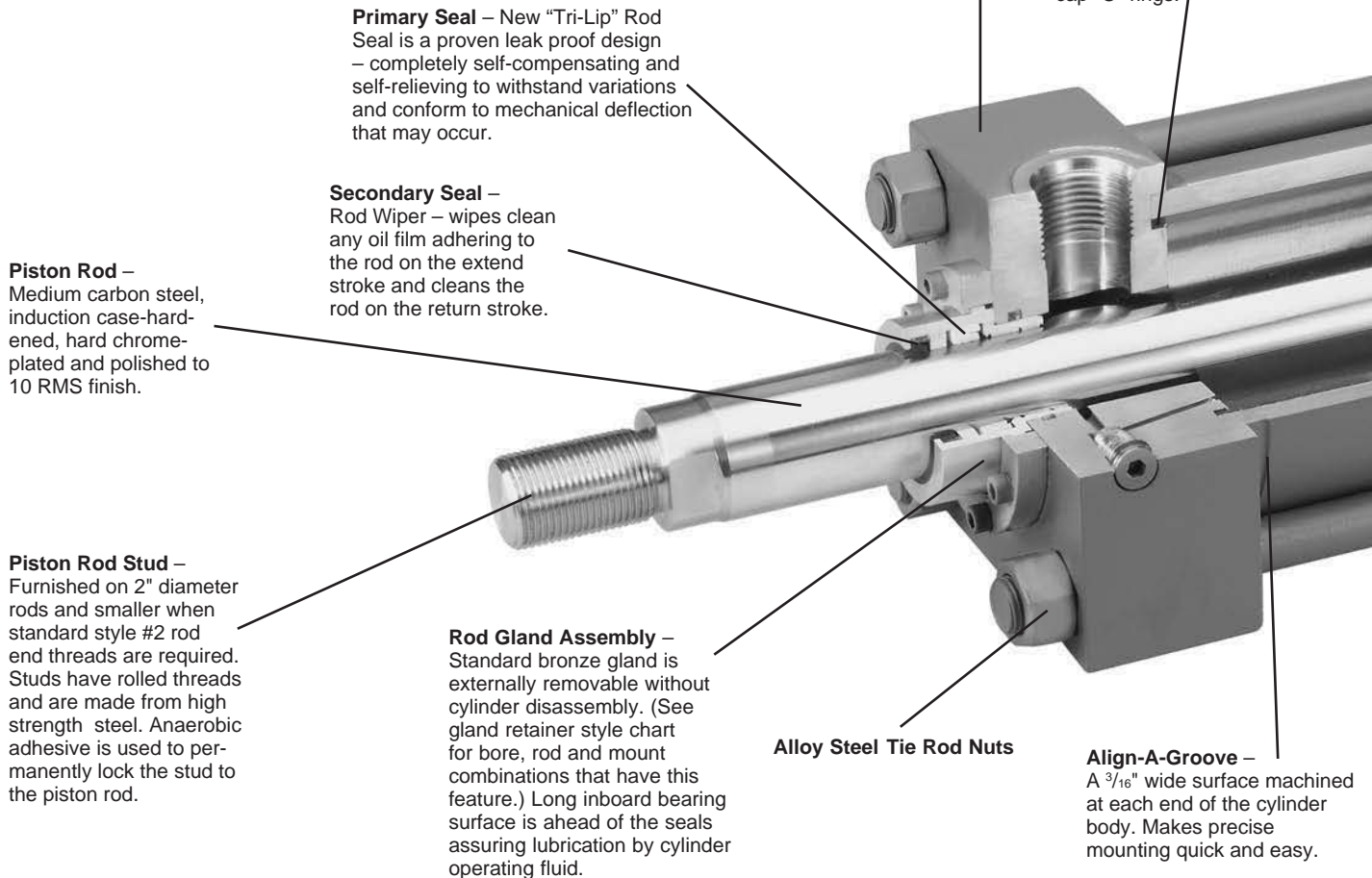

Primary Seal – New “Tri-Lip” Rod Seal is a proven leak proof design – completely self-compensating and self-relieving to withstand variations and conform to mechanical deflection that may occur.

Secondary Seal – Rod Wiper – wipes clean any oil film adhering to the rod on the extend stroke and cleans the rod on the return stroke.

Piston Rod – Medium carbon steel, induction case-hardened, hard chrome-plated and polished to 10 RMS finish.

Piston Rod Stud – Furnished on 2" diameter rods and smaller when standard style #2 rod end threads are required. Studs have rolled threads and are made from high strength steel. Anaerobic adhesive is used to permanently lock the stud to the piston rod.

Rod Gland Assembly – Standard bronze gland is externally removable without cylinder disassembly. (See gland retainer style chart for bore, rod and mount combinations that have this feature.) Long inboard bearing surface is ahead of the seals assuring lubrication by cylinder operating fluid.

Alloy Steel Tie Rod Nuts

Steel Head – Bored and grooved to provide concentricity for mating parts.

End Seal – Pressure-actuated cylinder tube-to-head and cap “O” rings.

Align-A-Groove – A $\frac{3}{16}$ " wide surface machined at each end of the cylinder body. Makes precise mounting quick and easy.

Schrader Bellows stepped floating cushions combine the best features of known cushion technology.

Deceleration devices or built-in “cushions” are optional and can be supplied at head end, cap end, or both ends without change in envelope or mounting dimensions. Schrader Bellows cylinder cushions are a stepped design and combine the best features of known cushion technology.

Standard straight or tapered cushions have been used in industrial cylinders over a very broad range of applications. Schrader Bellows research has found that both designs have their limitations.

As a result, Schrader Bellows has taken a new approach in cushioning of industrial hydraulic cylinders and for specific load and velocity conditions have been able to obtain deceleration curves that come very close to the ideal. The success lies in a stepped sleeve or spear concept where the steps are calculated to approximate theoretical orifice areas curves.

In the cushion performance chart, pressure traces show the results of typical orifice flow conditions. Tests of a three-step sleeve or spear show three pressure pulses coinciding with the steps. The deceleration curve shape comes very close to being theoretical, with the exception of the last $\frac{1}{2}$ inch of travel.

This is a constant shape in order to have some flexibility in application.

The stepped cushion design shows reduced pressure peaks for most load and speed conditions, with comparable reduction of objectionable stopping forces being transmitted to the load and the support structure.

All Schrader Bellows PH-2 cushions are adjustable.

The PH-2 Series cylinder design incorporates the longest cushion sleeve or spear that can be provided in the standard envelope without decreasing the rod bearing and piston bearing lengths.

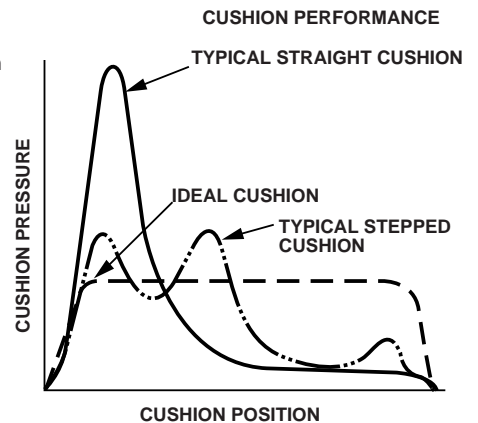

Adjustable Floating Stepped Cushions – For maximum performance – economical and flexible for even the most demanding applications – provides superior performance in reducing shock. Cushions are optional and can be supplied at head end, cap end, or both ends without change in envelope or mounting dimensions.

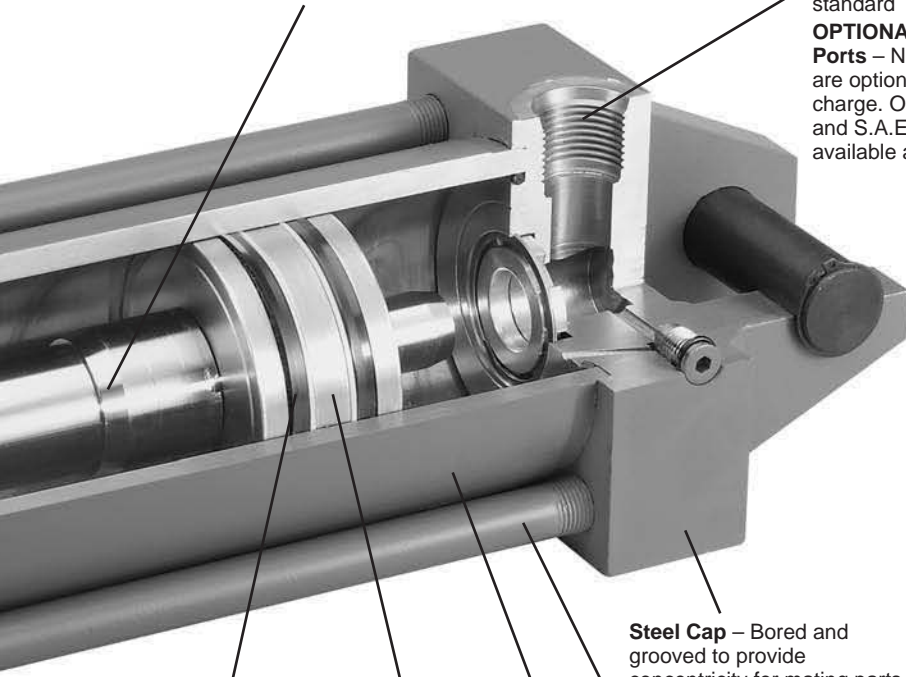

Ports – S.A. E. "O"-ring ports are standard
OPTIONAL PORTS
Ports – N.P.T.F. ports are optional at no extra charge. Oversize N.P.T.F. and S.A.E. ports are available at extra charge.

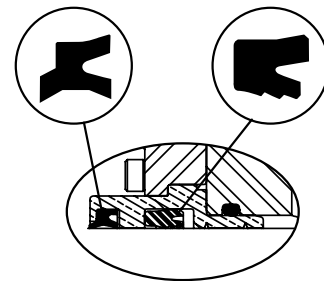

Gland Assembly with "Tri-Lip" Rod Seal

Gland Assembly externally removable without cylinder disassembly. (See gland retainer style chart for bore, rod and mount combinations that have this feature.) An O-ring is used as a seal between the gland and head. The "Tri-Lip" rod seal has multiple sealing edges to produce "dry rod" performance. It is molded from a special polyurethane material that is extremely resistant to abrasion and extrusion, resulting in exceptional service life. Wiperseal cleans rod of dirt, preventing it from entering the gland and also acts as a secondary rod seal.

Lipseal™ Piston – Zero leakage under static conditions for hydraulic pressures up to 3000 PSI. Seals are self-compensating to conform to variations in pressure, mechanical deflection, and wear. Back-up washer prevents extrusion.

One-Piece Nodular Iron Piston – The wide piston surface contacting cylinder bore reduces bearing loads. Anaerobic adhesive is used to permanently lock and seal the piston to the rod.

Steel Cap – Bored and grooved to provide concentricity for mating parts.

High Strength Tie Rods – Made from 100,000 PSI minimum yield steel with rolled threads for added strength.

The Cylinder Tube – Heavy-wall steel tubing, honed to a micro finish bore.

OPTIONAL PISTONS

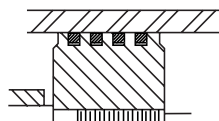

Step cut iron piston rings are optional.

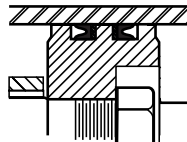

Piston with Retainer Nut – Optional at no extra charge.

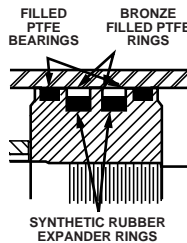

Hi Load Piston – Optional at extra charge (1½" - 6" Bores). Includes wear rings and bronze-filled PTFE seals. Two wear rings serve as bearings which deform radially under side-loading, enabling the load to be spread over a larger area and reduce unit loading. Bronze-filled PTFE seals are designed for extrusion-free, leak-proof service and longer cylinder life than the lipseal type piston. Not available with retainer nut.

(1) When a cushion is specified at the head end:

- a. A self-centering stepped sleeve is furnished on the piston rod assembly.
- b. A needle valve is provided that is flush with the side of the head even when wide open. It may be identified by the fact that it is socket-keyed. It is located on side number 2, in all mounting styles except MT1, MT2, MT4, ME5 and ME6. In these models it is located on side number 3.
- c. On 6" bore and larger cylinders, a springless check valve is provided that is also flush with the side of the head and is mounted adjacent to the needle valve except on Style MS2, where it is mounted opposite the needle valve. It may be identified by the fact that it is slotted.
- d. On 1½" - 5" bore cylinders a slotted sleeve design is used in place of the check valve.
- e. 1½" - 2½" bore cylinders use cartridge style needle valve (see Figure A).

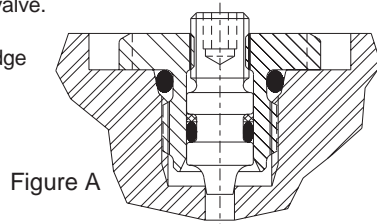
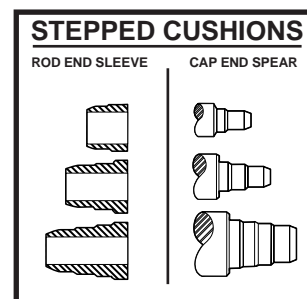

Figure A

(2) When a cushion is specified at the cap end:

- a. A stepped spear is provided on the piston rod.
- b. A "float check" self-centering bushing is provided which incorporates a large flow check valve for fast "out-stroke" action.
- c. A socket-keyed needle valve is provided that is flush with the side of the cap when wide open. It is located on side number 2 in all mounting styles except MT1, MT2, MT4, ME5 and ME6. In these models it is located on side number 3.



**Tie Rods Extended Both Ends Mount
NFFA Style MX1**

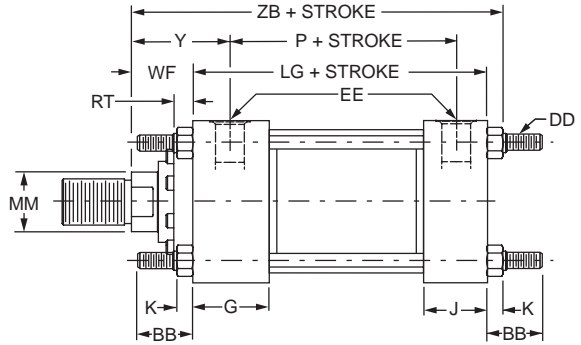
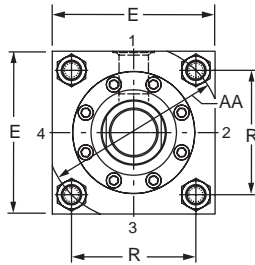
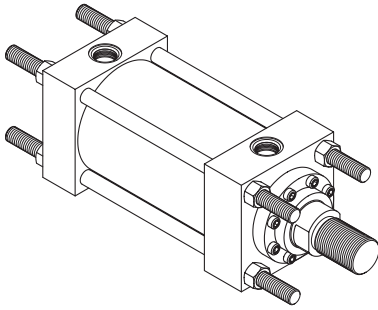

**Tie Rods Extended Cap End Mount
NFFA Style MX2**

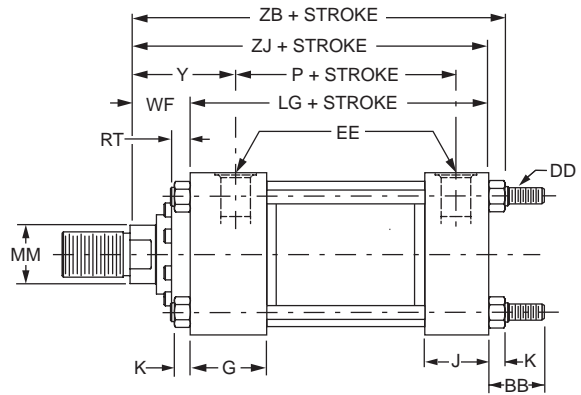
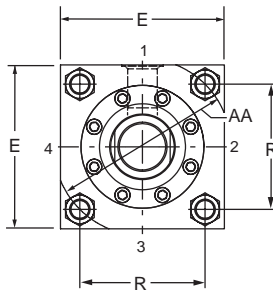
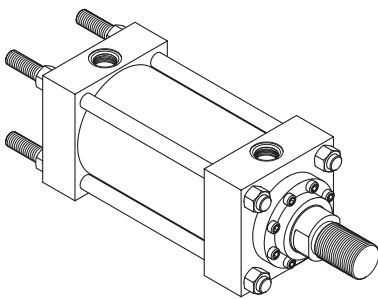

**Tie Rods Extended Head End Mount
NFFA Style MX3**

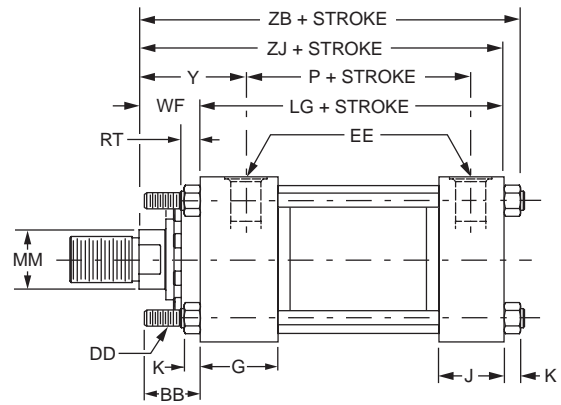
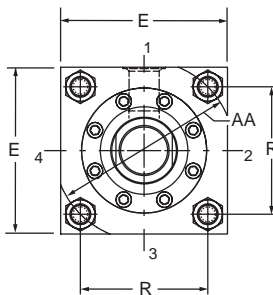
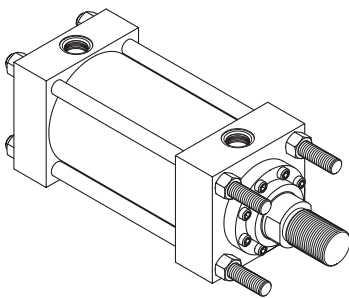

Rod End Dimensions for Full Face Retainers – See Table 2

See gland retainer style chart to determine which bore, rod and mount combinations have this feature.

**Thread Style 2
Small Male**

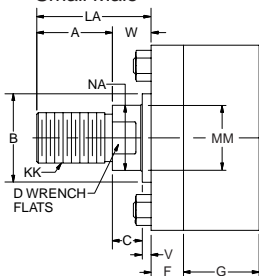

**Thread Style 4
Intermediate Male**

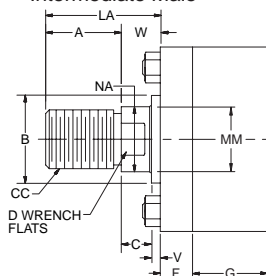

**Thread Style 3
Short Female**

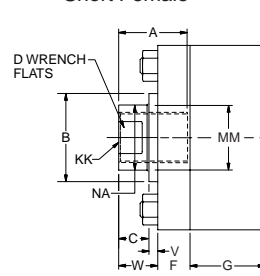

Style 3 stroke restrictions may apply. See Style 3 Minimum Stroke page for details.

“Special” Thread Style 0

Special thread, extension, rod eye, blank, etc., are also available.

To order, specify “Style 0” and give desired dimensions for KK, A and W. If otherwise special, furnish dimensioned sketch.

A high strength rod end stud is supplied on thread style 2 through 2" diameter rods. Larger sizes or special rod ends are cut threads. Style 2 rod ends are recommended where the workpiece is secured against the rod shoulder. When the workpiece is not shouldered, style 2 rod ends are recommended through 2"

piston rod diameters and style 4 rod ends are recommended on larger diameters. Use style 3 for applications where female rod end threads are required. If rod end is not specified, style 2 will be supplied.

Mounting Information – 1½" to 6" Bore

Table 1—Envelope and Mounting Dimensions

Bore	AA	BB	DD	E	EE		F	G	J	K	R	Add Stroke	
					NPTF [⊖]	SAE* [⊕]						LG	P
1½	2.3	1⅜ [†]	⅜-24	2½	½	10	⅜	1¾	1½	⅜	1.63	4⅝	2⅞
2	2.9	1⅓ [†]	½-20	3	½	10	⅝	1¾	1½	⅞ ₁₆	2.05	4⅝	2⅞
2½	3.6	1⅓ ₁₆	½-20	3½	½	10	⅝	1¾	1½	⅞ ₁₆	2.55	4¾	3
3¼	4.6	2⅝ ₁₆	⅝-18	4½	¾	12	¾	2	1¾	⅑ ₁₆	3.25	5½	3½
4	5.4	2⅝ ₁₆	⅝-18	5	¾	12	⅞	2	1¾	⅑ ₁₆	3.82	5¾	3¾
5	7.0	3⅓ ₁₆	⅞-14	6½	¾	12	⅞	2	1¾	⅓ ₁₆	4.95	6¼	4¼
6	8.1	3⅝	1-14	7½	1	16	1	2¼	2¼	⅞	5.73	7⅝	4⅞

* SAE straight thread ports are standard and are indicated by port number.

⊖ NPTF ports are available at no extra charge.

† 1½" and 2" bore Styles MX1 and MX3 are only available with full face retainer construction (see gland retainer style chart). Head end 'BB' dimension for these bores is referenced from the front of full square retainer that is 'F' dimension thick.

Table 2—Rod Dimensions

Bore	Rod Dia. MM	Thread		Rod Extensions and Pilot Dimensions														Add Stroke		
		Style 4 CC	Style 2 & 3 KK	A	+0.000 -0.002 B	C	D	LA	LAF	NA	RD (Max.)	RT	V	VF	VH	W	WF	Y	ZB	ZJ
1½	⅝	½-20	⅞-20	¾	1.124	⅜	½	1⅜	1¾	⅑ ₁₆	1⅓ ₁₆	⅜	¼	¼	⅜ ₁₆	⅝	1	2	6	5⅝
	1	⅞-14	¾-16	1⅞	1.499	½	⅞	2⅞	2½	⅓ ₁₆	2⅓ ₁₆	⅜	½	½	⅜ ₁₆	1	1⅓	2⅞	6⅞	6
2	1	⅞-14	¾-16	1⅞	1.499	½	⅞	1⅞	2½	⅓ ₁₆	2⅓ ₁₆	⅜	¼	½	⅜ ₁₆	¾	1⅓	2⅞	6⅞	6
	1⅜	1¼-12	1-14	1⅝	1.999	⅝	1⅞	2⅝	3¼	⅓ ₁₆	2⅞	⅜	⅜	⅝	⅜ ₁₆	1	1⅝	2⅝	6⅓ ₁₆	6¼
2½	1	⅞-14	¾-16	1⅞	1.499	½	⅞	—	2½	⅓ ₁₆	2⅓ ₁₆	⅜	¼	½	⅜ ₁₆	—	1⅓	2⅞	6⅓ ₁₆	6⅞
	1⅜	1¼-12	1-14	1⅝	1.999	⅝	1⅞	—	3¼	⅓ ₁₆	2⅞	⅜	⅜	⅝	⅜ ₁₆	—	1⅝	2⅝	6⅓ ₁₆	6⅞
3¼	1⅜	1¼-12	1¼-12	2	2.374	¾	1½	—	3⅞	1⅓ ₁₆	3⅓ ₁₆	⅝	½	½	⅜ ₁₆	—	1⅞	2⅞	7⅓ ₁₆	6⅝
	1⅜	1¼-12	1¼-12	2	2.374	¾	1½	—	3⅞	1⅓ ₁₆	3⅓ ₁₆	⅝	½	½	⅜ ₁₆	—	1⅞	2⅞	7⅓ ₁₆	6⅝
4	2	1¾-12	1½-12	2¼	2.624	⅞	1⅓ ₁₆	—	4¼	1⅓ ₁₆	3⅓ ₁₆	⅝	⅜	½	¼	—	2	3⅞	8⅓ ₁₆	7½
	2½	2¼-12	1⅞-12	3	3.124	1	2⅓ ₁₆	—	5¼	2⅓ ₁₆	4¼	⅝	⅜	⅝	¼	—	2¼	3⅞	8⅓ ₁₆	8
5	2	1¾-12	1½-12	2¼	2.624	⅞	1⅓ ₁₆	—	4¼	1⅓ ₁₆	3⅓ ₁₆	⅝	¼	½	¼	—	2	3⅞	9⅓ ₁₆	8¼
	2½	2¼-12	1⅞-12	3	3.124	1	2⅓ ₁₆	—	5¼	3⅓ ₁₆	4¼	⅝	⅜	⅝	¼	—	2¼	3⅞	9⅓ ₁₆	8½
6	3	2⅜-12	2¼-12	3½	3.749	1	2⅝	—	5¾	2⅞	5⅞	⅞	⅜	⅝ ₁₆	—	—	2¼	3⅞	9⅓ ₁₆	8½
	3½	3¼-12	2½-12	3½	4.249	1	3	—	5¾	2⅞	5⅞	⅞	⅜	⅝ ₁₆	—	—	2¼	3⅞	9⅓ ₁₆	8½
6	2½	2¼-12	1⅞-12	3	3.124	1	2⅓ ₁₆	—	5¼	2⅓ ₁₆	4¼	⅝	¼	⅝	¼	—	2¼	3½	10½	9⅝
	3	2⅜-12	2¼-12	3½	3.749	1	2⅝	—	5¾	2⅞	5⅞	⅞	¼	⅝ ₁₆	—	—	2¼	3½	10½	9⅝
6	3½	3¼-12	2½-12	3½	4.249	1	3	—	5¾	3⅓ ₁₆	5⅞	⅞	¼	⅝ ₁₆	—	—	2¼	3½	10½	9⅝
	4	3⅜-12	3-12	4	4.749	1	3⅝	—	6¼	3⅞	6⅓ ₁₆	⅞	¼	⅝ ₁₆	—	—	2¼	3½	10½	9⅝

Table 3—Envelope and Mounting Dimensions

Rod End Dimensions for Bolted Retainers – See Table 2

See gland retainer style chart to determine which bore, rod and mount combinations have this feature.

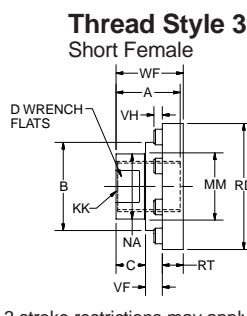
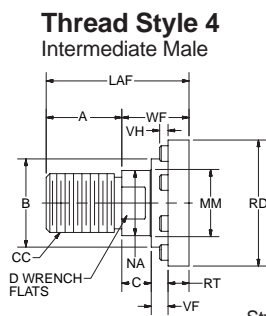
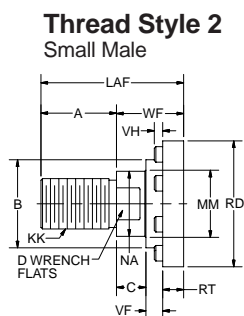

Style 3 stroke restrictions may apply. See Style 3 Minimum Stroke page for details.

A high strength rod end stud is supplied on thread style 2 through 2" diameter rods. Larger sizes or special rod ends are cut threads. Style 2 rod ends are recommended where the workpiece is secured against the rod shoulder. When the workpiece is not shouldered, style 2 rod ends are recommended through 2" piston rod diameters and style 4 rod ends are recommended on larger diameters. Use style 3 for applications where female rod end threads are required. If rod end is not specified, style 2 will be supplied.

"Special" Thread Style 0

Special thread, extension, rod eye, blank, etc., are also available.

To order, specify "Style 0" and give desired dimensions for KK, A and WF. If otherwise special, furnish dimensioned sketch.

**Head Rectangular
Flange Mount
NFFPA Style MF1**

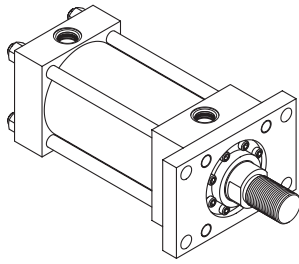

Maximum Pressure Rating - PSI
Push Application

Bore	Rod Dia				
	5/8	1	1 3/8	1 3/4	2
1 1/2	1400	1000	-	-	-
2	-	2000	1200	-	-
2 1/2	-	700	700	1000	-
3 1/4	-	-	800	800	600
4	-	-	-	1000	1000
5	-	-	-	-	850
Bore	Rod Dia				
	2 1/2	3	3 1/2	4	5
4	700	-	-	-	-
5	850	450	800	-	-
6	650	650	400	400	-

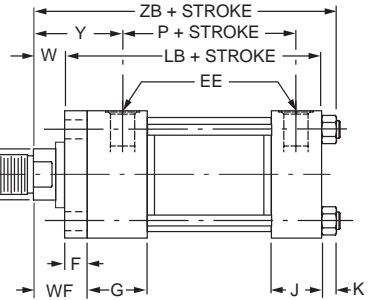
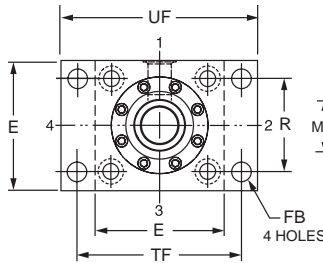

**Head Square
Flange Mount
NFFPA Style MF5**

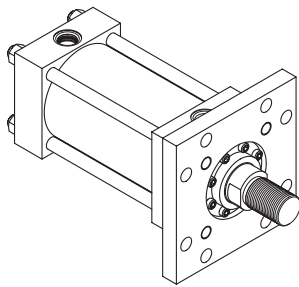

Maximum Pressure Rating - PSI
Push Application

Bore	Rod Dia				
	5/8	1	1 3/8	1 3/4	2
1 1/2	3000	3000	-	-	-
2	-	3000	3000	-	-
2 1/2	-	3000	3000	3000	-
3 1/4	-	-	3000	3000	3000
4	-	-	-	3000	3000
5	-	-	-	-	2500
Bore	Rod Dia				
	2 1/2	3	3 1/2	4	5
4	3000	-	-	-	-
5	2500	1800	2300	-	-
6	2000	2000	1600	1600	-

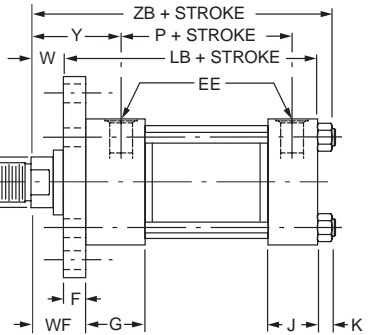
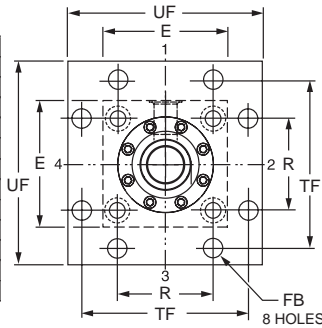

**Head Rectangular Mount
NFFPA Style ME5**

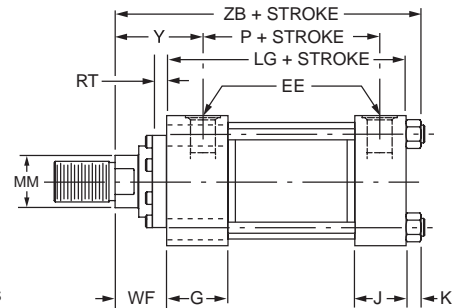
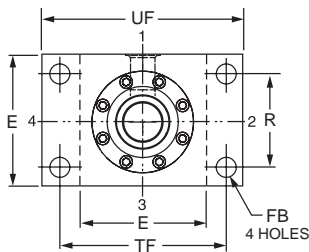
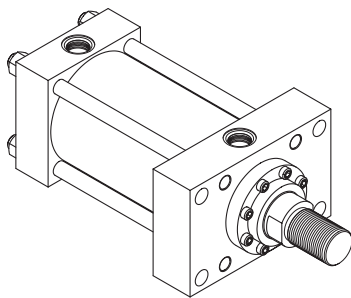

Rod End Dimensions for Full Face Retainers – See Table 2

See gland retainer style chart to determine which bore, rod and mount combinations have this feature.

**Thread Style 2
Small Male**

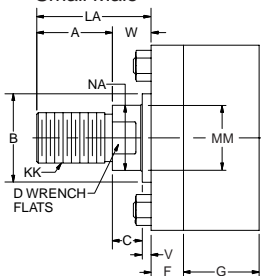

**Thread Style 4
Intermediate Male**

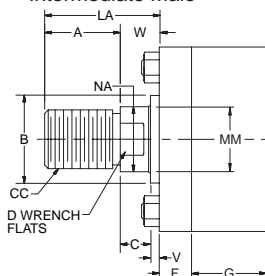

**Thread Style 3
Short Female**

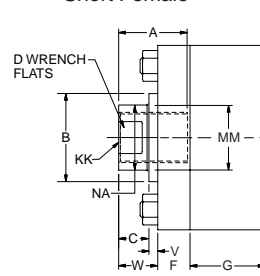

**“Special” Thread
Style 0**

Special thread, extension, rod eye, blank, etc., are also available.

To order, specify “Style 0” and give desired dimensions for KK, A and W. If otherwise special, furnish dimensioned sketch.

Style 3 stroke restrictions may apply. See Style 3 Minimum Stroke page for details.

A high strength rod end stud is supplied on thread style 2 through 2" diameter rods. Larger sizes or special rod ends are cut threads. Style 2 rod ends are recommended where the workpiece is secured against the rod shoulder. When the workpiece is not shouldered, style 2 rod ends are recommended through 2"

piston rod diameters and style 4 rod ends are recommended on larger diameters. Use style 3 for applications where female rod end threads are required. If rod end is not specified, style 2 will be supplied.

Mounting Information – 1½" to 6" Bore

Table 1—Envelope and Mounting Dimensions

Bore	E	EE		F	FB	G	J	K	R	TF	UF	Add Stroke		
		NPTF [⊖]	SAE ⁺									LB	LG	P
1½	2½	½	10	¾	7/16	1¾	1½	¾	1.63	37/16	4¼	5	4⅝	27/8
2	3	½	10	⅝	9/16	1¾	1½	7/16	2.05	4⅞	5⅞	5¼	4⅝	27/8
2½	3½	½	10	⅝	9/16	1¾	1½	7/16	2.55	4⅝	5⅝	5⅝	4¾	3
3¼	4½	¾	12	¾	11/16	2	1¾	9/16	3.25	57/8	7⅞	6¼	5½	3½
4	5	¾	12	7/8	11/16	2	1¾	9/16	3.82	6⅜	7⅝	6⅝	5¾	3¾
5	6½	¾	12	7/8	15/16	2	1¾	13/16	4.95	83/16	9¾	7⅞	6¼	4¼
6	7½	1	16	1	11/16	2¼	2¼	7/8	5.73	97/16	11¼	8⅜	7⅜	47/8

* SAE straight thread ports are standard and are indicated by port number.

⊖ NPTF ports are available at no extra charge.

Table 2—Rod Dimensions

Bore	Rod Dia. MM	Thread		Rod Extensions and Pilot Dimensions														Y	ZB	Add Stroke
		Style 4 CC	Style 2 & 3 KK	A	+0.000 -0.002 B	C	D	LA	LAF	NA	RD (Max.)	RT	V	VF	VH	W	WF			
1½	5/8	1/2-20	7/16-20	¾	1.124	¾	1/2	1¾	1¾	9/16	115/16	¾	1/4	1/4	3/16	5/8	1	2	6	
	1	7/8-14	¾-16	1⅞	1.499	1/2	7/8	2⅞	2½	15/16	23/8	¾	1/2	1/2	3/16	1	13/8	23/8	63/8	
2	1	7/8-14	¾-16	1⅞	1.499	1/2	7/8	17/8	2½	15/16	23/8	¾	1/4	1/2	3/16	¾	13/8	23/8	67/16	
	13/8	1¼-12	1-14	15/8	1.999	5/8	1⅞	25/8	3¼	15/16	27/8	¾	3/8	5/8	3/16	1	15/8	25/8	611/16	
2½	1	7/8-14	¾-16	1⅞	1.499	1/2	7/8	17/8	2½	15/16	23/8	¾	1/4	1/2	3/16	¾	13/8	23/8	69/16	
	13/8	1¼-12	1-14	15/8	1.999	5/8	1⅞	25/8	3¼	15/16	27/8	¾	3/8	5/8	3/16	1	15/8	25/8	613/16	
3¼	13/8	1¼-12	1-14	15/8	1.999	5/8	1⅞	2½	3¼	11/16	315/32	5/8	1/2	1/2	3/16	1¼	17/8	27/8	71/16	
	1¾	1½-12	1¼-12	2	2.374	¾	1½	3¼	37/8	11/16	315/32	5/8	3/8	1/2	3/16	11/8	17/8	3	715/16	
4	1¾	1½-12	1¼-12	2	2.374	¾	1½	3	37/8	11/16	315/32	5/8	1/4	1/2	3/16	1	17/8	3	83/16	
	2	1¾-12	1½-12	2¼	2.624	7/8	11/16	33/8	4¼	15/16	323/32	5/8	1/4	1/2	1/4	11/8	2	31/8	85/16	
5	2½	2¼-12	17/8-12	3	3.124	1	21/16	43/8	5¼	23/8	4¼	5/8	3/8	5/8	1/4	13/8	2¼	33/8	89/16	
	2	1¾-12	1½-12	2¼	2.624	7/8	11/16	33/8	4¼	15/16	323/32	5/8	1/4	1/2	1/4	11/8	2	31/8	91/16	
6	2½	2¼-12	17/8-12	3	3.124	1	21/16	4¼	5¼	23/8	4¼	5/8	1/4	5/8	1/4	11/4	2¼	3½	10½	
	3	2¾-12	2¼-12	3½	3.749	1	25/8	47/8	5¾	27/8	57/16	7/8	3/8	5/16	—	13/8	2¼	33/8	95/16	
6	3½	3¼-12	2½-12	3½	4.249	1	3	47/8	5¾	33/8	515/16	15/16	3/8	5/16	—	13/8	2¼	33/8	95/16	
	2½	2¼-12	17/8-12	3	3.124	1	21/16	4¼	5¼	23/8	4¼	5/8	1/4	5/8	1/4	11/4	2¼	3½	10½	
6	3	2¾-12	2¼-12	3½	3.749	1	25/8	4¾	5¾	27/8	57/16	7/8	1/4	5/16	—	11/4	2¼	3½	10½	
	3½	3¼-12	2½-12	3½	4.249	1	3	4¾	5¾	33/8	515/16	15/16	1/4	5/16	—	11/4	2¼	3½	10½	
6	4	3¾-12	3-12	4	4.749	1	33/8	5¼	6¼	37/8	65/16	15/16	1/4	5/16	—	11/4	2¼	3½	10½	

Table 3 — Envelope and Mounting Dimensions

Rod End Dimensions for Bolted Retainers – See Table 2

See gland retainer style chart to determine which bore, rod and mount combinations have this feature.

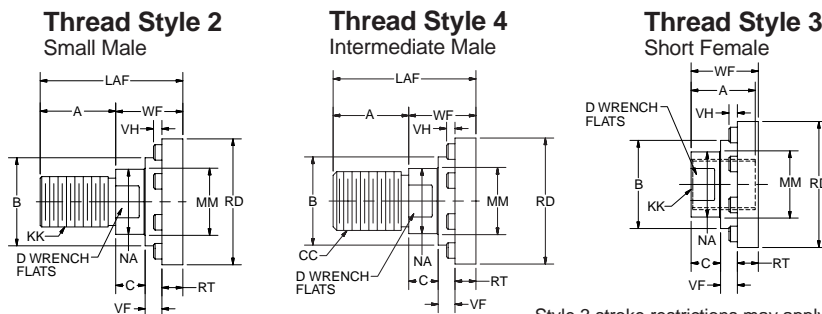

Style 3 stroke restrictions may apply. See Style 3 Minimum Stroke page for details.

A high strength rod end stud is supplied on thread style 2 through 2" diameter rods. Larger sizes or special rod ends are cut threads. Style 2 rod ends are recommended where the workpiece is secured against the rod shoulder. When the workpiece is not shouldered, style 2 rod ends are recommended through 2" piston rod diameters and style 4 rod ends are recommended on larger diameters. Use style 3 for applications where female rod end threads are required. If rod end is not specified, style 2 will be supplied.

“Special” Thread Style 0

Special thread, extension, rod eye, blank, etc., are also available.

To order, specify “Style 0” and give desired dimensions for KK, A and WF. If otherwise special, furnish dimensioned sketch.

Cap Rectangular
Flange Mount
NFFA Style MF2

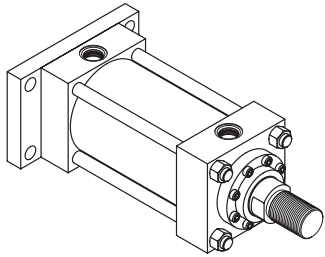

Maximum Pressure Rating - PSI
Pull Application

Bore	Rod Dia				
	5/8	1	1 3/8	1 3/4	2
1 1/2	2500	3000	-	-	-
2	-	3000	3000	-	-
2 1/2	-	3000	3000	3000	-
3 1/4	-	-	3000	3000	3000
4	-	-	-	3000	3000
5	-	-	-	-	2000
Bore	Rod Dia				
	2 1/2	3	3 1/2	4	5
4	3000	-	-	-	-
5	2000	2500	3000	-	-
6	1800	2000	2000	2500	-

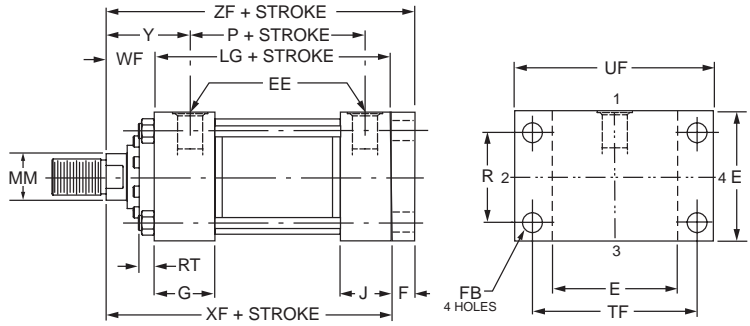

Cap Square Flange Mount
NFFA Style MF6

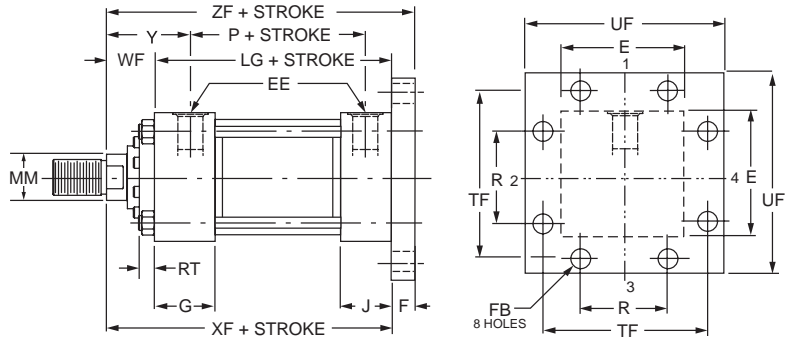
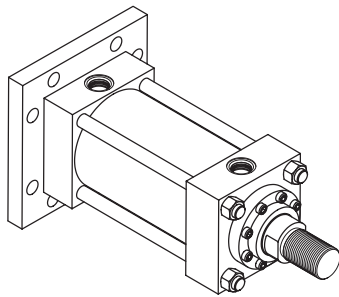

Cap Rectangular Mount
NFFA Style ME6

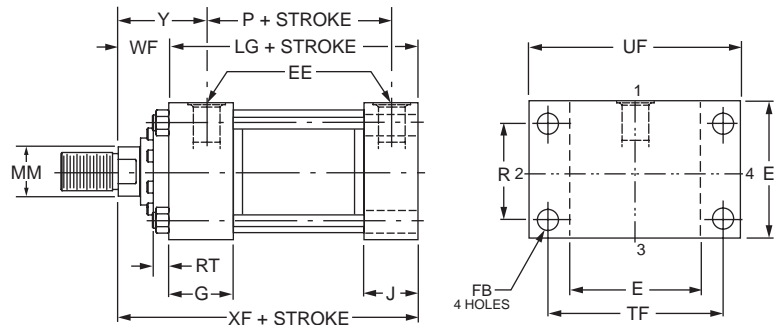
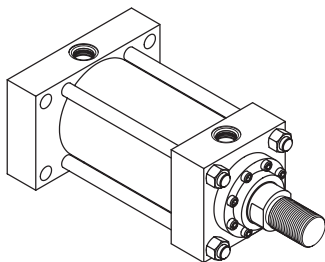

Rod End Dimensions for Full Face Retainers – See Table 2

See gland retainer style chart to determine which bore, rod and mount combinations have this feature.

Thread Style 2
Small Male

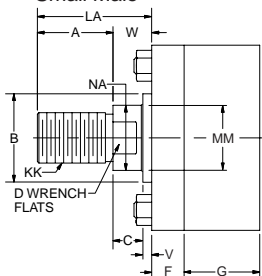

Thread Style 4
Intermediate Male

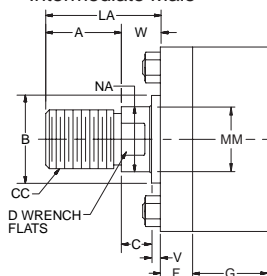

Thread Style 3
Short Female

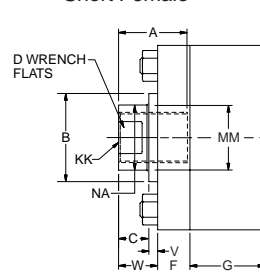

“Special” Thread
Style 0

Special thread, extension, rod eye, blank, etc., are also available.

To order, specify “Style 0” and give desired dimensions for KK, A and W. If otherwise special, furnish dimensioned sketch.

Style 3 stroke restrictions may apply. See Style 3 Minimum Stroke page for details.

A high strength rod end stud is supplied on thread style 2 through 2" diameter rods. Larger sizes or special rod ends are cut threads. Style 2 rod ends are recommended where the workpiece is secured against the rod shoulder. When the workpiece is not shouldered, style 2 rod ends are recommended through 2"

piston rod diameters and style 4 rod ends are recommended on larger diameters. Use style 3 for applications where female rod end threads are required. If rod end is not specified, style 2 will be supplied.

Mounting Information – 1 1/2" to 6" Bore

Table 1—Envelope and Mounting Dimensions

Bore	E	EE		F	FB	G	J	K	R	TF	UF	Add Stroke	
		NPTF [⊖]	SAE*									LG	P
1 1/2	2 1/2	1/2	10	3/8	7/16	1 3/4	1 1/2	3/8	1.63	3 7/16	4 1/4	4 5/8	2 7/8
2	3	1/2	10	5/8	9/16	1 3/4	1 1/2	7/16	2.05	4 1/8	5 1/8	4 5/8	2 7/8
2 1/2	3 1/2	1/2	10	5/8	9/16	1 3/4	1 1/2	7/16	2.55	4 5/8	5 5/8	4 3/4	3
3 1/4	4 1/2	3/4	12	3/4	1 1/16	2	1 3/4	9/16	3.25	5 7/8	7 1/8	5 1/2	3 1/2
4	5	3/4	12	7/8	1 1/16	2	1 3/4	9/16	3.82	6 3/8	7 5/8	5 3/4	3 3/4
5	6 1/2	3/4	12	7/8	1 5/16	2	1 3/4	1 3/16	4.95	8 3/16	9 3/4	6 1/4	4 1/4
6	7 1/2	1	16	1	1 1/16	2 1/4	2 1/4	7/8	5.73	9 7/16	11 1/4	7 3/8	4 7/8

* SAE straight thread ports are standard and are indicated by port number.

⊖ NPTF ports are available at no extra charge.

Table 2—Rod Dimensions

Bore	Rod Dia. MM	Thread		Rod Extensions and Pilot Dimensions													Add Stroke			
		Style 4 CC	Style 2 & 3 KK	A	+0.000 -0.002 B	C	D	LA	LAF	NA	RD (Max.)	RT	V	VF	VH	W	WF	Y	XF	ZF
1 1/2	5/8	1/2-20	7/16-20	3/4	1.124	3/8	1/2	—	1 3/4	9/16	1 15/16	3/8	1/4	1/4	3/16	—	1	2	5 5/8	6
	1	7/8-14	3/4-16	1 1/8	1.499	1/2	7/8	2 1/8	2 1/2	1 5/16	2 3/8	3/8	1/2	1/2	3/16	1	1 3/8	2 3/8	6	6 3/8
2	1	7/8-14	3/4-16	1 1/8	1.499	1/2	7/8	—	2 1/2	1 5/16	2 3/8	3/8	1/4	1/2	3/16	—	1 3/8	2 3/8	6	6 5/8
	1 3/8	1 1/4-12	1-14	1 5/8	1.999	5/8	1 1/8	2 5/8	3 1/4	1 5/16	2 7/8	3/8	3/8	5/8	3/16	1	1 5/8	2 5/8	6 1/4	6 7/8
2 1/2	1	7/8-14	3/4-16	1 1/8	1.499	1/2	7/8	—	2 1/2	1 5/16	2 3/8	3/8	1/4	1/2	3/16	—	1 3/8	2 3/8	6 1/8	6 3/4
	1 3/8	1 1/4-12	1-14	1 5/8	1.999	5/8	1 1/8	—	3 1/4	1 5/16	2 7/8	3/8	3/8	5/8	3/16	—	1 5/8	2 5/8	6 3/8	7
3 1/4	1 3/8	1 1/4-12	1-14	1 5/8	1.999	5/8	1 1/8	—	3 1/4	1 5/16	2 7/8	3/8	1/4	1/2	3/16	—	1 5/8	2 3/4	7 1/8	7 7/8
	1 3/4	1 1/2-12	1 1/4-12	2	2.374	3/4	1 1/2	—	3 7/8	1 11/16	3 15/32	5/8	1/2	1/2	3/16	—	1 7/8	2 7/8	6 5/8	7 1/4
4	1 3/4	1 1/2-12	1 1/4-12	2	2.374	3/4	1 1/2	—	3 7/8	1 11/16	3 15/32	5/8	3/8	1/2	3/16	—	1 7/8	3	7 3/8	8 1/8
	2	1 3/4-12	1 1/2-12	2 1/4	2.624	7/8	1 11/16	—	4 1/4	1 15/16	3 23/32	5/8	3/8	1/2	1/4	—	2	3 1/8	7 1/2	8 1/4
5	1 3/4	1 1/2-12	1 1/4-12	2	2.374	3/4	1 1/2	—	3 7/8	1 11/16	3 15/32	5/8	1/4	1/2	3/16	—	1 7/8	3	7 5/8	8 1/2
	2	1 3/4-12	1 1/2-12	2 1/4	2.624	7/8	1 11/16	—	4 1/4	1 15/16	3 23/32	5/8	1/4	1/2	1/4	—	2	3 1/8	7 3/4	8 5/8
6	2 1/2	2 1/4-12	1 7/8-12	3	3.124	1	2 1/16	—	5 1/4	2 3/8	4 1/4	5/8	3/8	5/8	1/4	—	2 1/4	3 3/8	8	8 7/8
	2	1 3/4-12	1 1/2-12	2 1/4	2.624	7/8	1 11/16	—	4 1/4	1 15/16	3 23/32	5/8	1/4	1/2	1/4	—	2	3 1/8	8 1/4	9 1/8
5	2 1/2	2 1/4-12	1 7/8-12	3	3.124	1	2 1/16	—	5 1/4	2 3/8	4 1/4	5/8	3/8	5/8	1/4	—	2 1/4	3 3/8	8 1/2	9 3/8
	3	2 3/4-12	2 1/4-12	3 1/2	3.749	1	2 5/8	—	5 3/4	2 7/8	5 7/16	7/8	3/8	5/16	—	—	2 1/4	3 3/8	8 1/2	9 3/8
6	3 1/2	3 1/4-12	2 1/2-12	3 1/2	4.249	1	3	—	5 3/4	3 3/8	5 15/16	1 5/16	3/8	5/16	—	—	2 1/4	3 3/8	8 1/2	9 3/8
	2 1/2	2 1/4-12	1 7/8-12	3	3.124	1	2 1/16	—	5 1/4	2 3/8	4 1/4	5/8	1/4	5/8	1/4	—	2 1/4	3 1/2	9 5/8	10 5/8
6	3	2 3/4-12	2 1/4-12	3 1/2	3.749	1	2 5/8	—	5 3/4	2 7/8	5 7/16	7/8	1/4	5/16	—	—	2 1/4	3 1/2	9 5/8	10 5/8
	3 1/2	3 1/4-12	2 1/2-12	3 1/2	4.249	1	3	—	5 3/4	3 3/8	5 15/16	1 5/16	1/4	5/16	—	—	2 1/4	3 1/2	9 5/8	10 5/8
6	4	3 3/4-12	3-12	4	4.749	1	3 3/8	—	6 1/4	3 7/8	6 5/16	1 5/16	1/4	5/16	—	—	2 1/4	3 1/2	9 5/8	10 5/8

Rod End Dimensions for Bolted Retainers – See Table 2

See gland retainer style chart to determine which bore, rod and mount combinations have this feature.

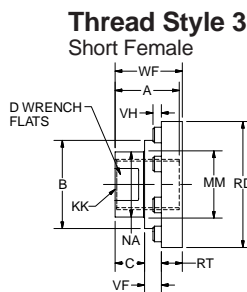
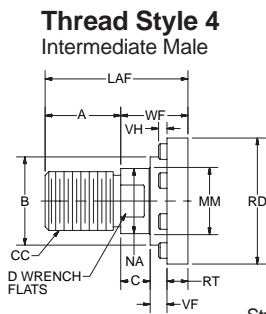
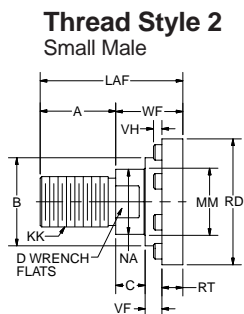

Style 3 stroke restrictions may apply. See Style 3 Minimum Stroke page for details.

A high strength rod end stud is supplied on thread style 2 through 2" diameter rods. Larger sizes or special rod ends are cut threads. Style 2 rod ends are recommended where the workpiece is secured against the rod shoulder. When the workpiece is not shouldered, style 2 rod ends are recommended through 2" piston rod diameters and style 4 rod ends are recommended on larger diameters. Use style 3 for applications where female rod end threads are required. If rod end is not specified, style 2 will be supplied.

“Special” Thread Style 0

Special thread, extension, rod eye, blank, etc., are also available.

To order, specify “Style 0” and give desired dimensions for KK, A and WF. If otherwise special, furnish dimensioned sketch.

**Side Lug Mount
NFPA Style MS2**

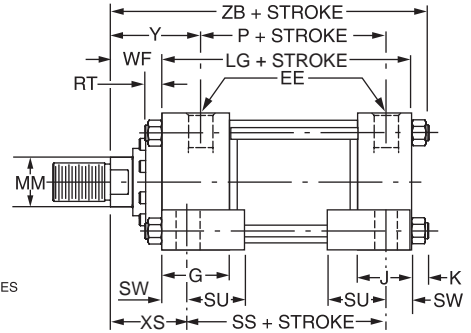
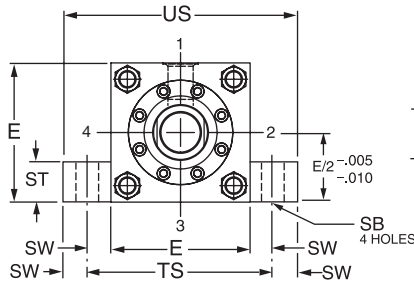
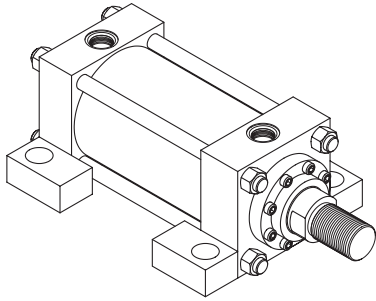

Style MS2 cylinders have mounting lugs welded to the head and cap, and are considered to be a fixed mount that does not absorb force on its centerline. The plane of the mounting surface is not through the centerline of the cylinder, and for this reason Style MS2 cylinders produce a turning moment as the cylinder applies force to the load. This turning moment tends to rotate the

cylinder about its mounting bolts. If the cylinder is not well secured to the machine member on which it is mounted or the load is not well-guided, this turning moment results in side load applied to rod gland and piston bearings. **To avoid this problem, Style MS2 cylinders should be specified with a stroke length at least equal to the bore size.**

**Side Tap Mount
NFPA Style MS4**

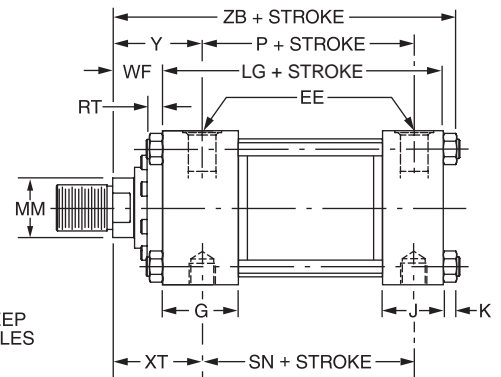
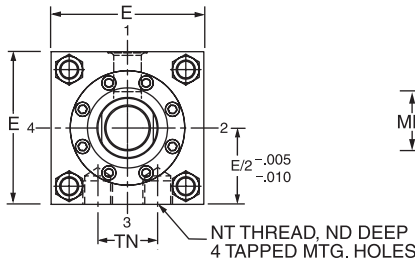
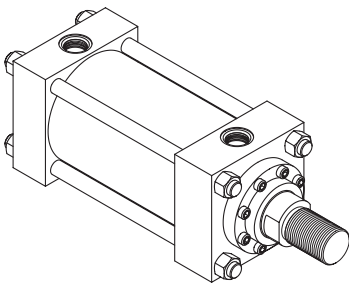

Style MS4 cylinders have side tapped holes for flush mounting, and are considered to be a fixed mount that does not absorb force on its centerline. The plane of the mounting surface is not through the centerline of the cylinder, and for this reason Style MS4 cylinders produce a turning moment as the cylinder applies force to the load. This turning moment tends to rotate the cylinder

about its mounting bolts. If the cylinder is not well secured to the machine member on which it is mounted or the load is not well-guided, this turning moment results in side load applied to rod gland and piston bearings. **To avoid this problem, Style MS4 cylinders should be specified with a stroke length at least equal to the bore size.**

Rod End Dimensions for Full Face Retainers – See Table 2

See gland retainer style chart to determine which bore, rod and mount combinations have this feature.

**Thread Style 2
Small Male**

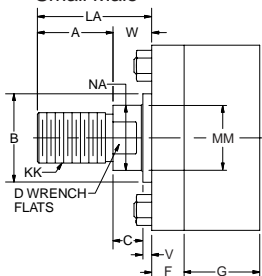

**Thread Style 4
Intermediate Male**

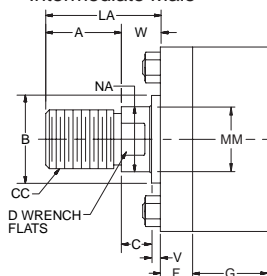

**Thread Style 3
Short Female**

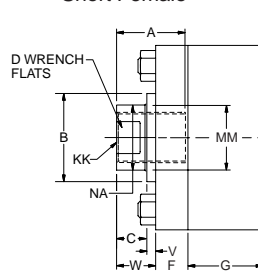

A high strength rod end stud is supplied on thread style 2 through 2" diameter rods. Larger sizes or special rod ends are cut threads. Style 2 rod ends are recommended where the workpiece is secured against the rod shoulder. When the workpiece is not shouldered, style 2 rod ends are recommended through 2"

piston rod diameters and style 4 rod ends are recommended on larger diameters. Use style 3 for applications where female rod end threads are required. If rod end is not specified, style 2 will be supplied.

"Special" Thread Style 0

Special thread, extension, rod eye, blank, etc., are also available.

To order, specify "Style 0" and give desired dimensions for KK, A and W. If otherwise special, furnish dimensioned sketch.

Style 3 stroke restrictions may apply. See Style 3 Minimum Stroke page for details.

Table 1—Envelope and Mounting Dimensions

Bore	E	EE		F	G	J	K	L	NT	R	SB	ST	SU	SW	TN	TS	US	Add Stroke			
		NPTF [⊖]	SAE*															LG	P	SN	SS
1½	2½	½	10	¾	1¾	1½	¾	¾	¾-16	1.63	7/16	½	15/16	¾	¾	¾	4	4 ⁵ / ₈	2 ⁷ / ₈	2 ⁷ / ₈	3 ⁷ / ₈
2	3	½	10	5/8	1¾	1½	7/16	1¼	½-13	2.05	9/16	¾	1¼	½	15/16	4	5	4 ⁵ / ₈	2 ⁷ / ₈	2 ⁷ / ₈	3 ⁵ / ₈
2½	3½	½	10	5/8	1¾	1½	7/16	1¼	5/8-11	2.55	13/16	1	1 ⁹ / ₁₆	11/16	15/16	4 ⁷ / ₈	6 ¹ / ₄	4 ³ / ₄	3	3	3 ³ / ₈
3¼	4½	¾	12	¾	2	1¾	9/16	1½	¾-10	3.25	13/16	1	1 ⁹ / ₁₆	11/16	1½	5 ⁷ / ₈	7¼	5½	3½	3½	4 ¹ / ₈
4	5	¾	12	7/8	2	1¾	9/16	2½	1-8	3.82	1½/16	1¼	2	7/8	2 ¹ / ₁₆	6¾	8½	5¾	3¾	3¾	4
5	6½	¾	12	7/8	2	1¾	13/16	2¼	1-8	4.95	1½/16	1¼	2	7/8	2 ¹⁵ / ₁₆	8¼	10	6¼	4¼	4¼	4½
6	7½	1	16	1	2¼	2¼	7/8	2½	1¼-7	5.73	15/16	1½	2½	1½	35/16	9¾	12	7¾	4¾	5½	5½

* SAE straight thread ports are standard and are indicated by port number.

⊖ NPTF ports are available at no extra charge.

Table 2—Rod Dimensions

Bore	Rod Dia. MM	Thread		Rod Extensions and Pilot Dimensions																	Add Stroke	
		Style 4 CC	Style 2 & 3 KK	A	+0.000 -0.002 B	C	D	LA	LAF	NA	RD (Max.)	RT	V	VF	VH	W	WF	ND	XS	XT	Y	ZB
1½	5/8	1/2-20	7/16-20	3/4	1.124	3/8	1/2	—	1¾	9/16	1 ¹⁵ / ₁₆	3/8	¼	¼	3/16	—	1	3/8	1¾	2	2	6
	1	7/8-14	¾-16	1½	1.499	½	7/8	2½	2½	15/16	2¾	3/8	½	½	3/16	1	1¾	3/8	1¾	2¾	2¾	6¾
2	1	7/8-14	¾-16	1½	1.499	½	7/8	—	2½	15/16	2¾	3/8	¼	½	3/16	—	1¾	7/16	1 ⁷ / ₈	2¾	2¾	6 ⁷ / ₁₆
	1¾	1¼-12	1-14	1½	1.999	5/8	1½	2½	3¼	15/16	2 ⁷ / ₈	3/8	3/8	5/8	3/16	1	1 ⁵ / ₈	7/16	2½	2½	2½	6 ¹¹ / ₁₆
2½	1	7/8-14	¾-16	1½	1.499	½	7/8	—	2½	15/16	2¾	3/8	¼	½	3/16	—	1¾	1/2	2½	2¾	2¾	6 ⁹ / ₁₆
	1¾	1¼-12	1-14	1½	1.999	5/8	1½	—	3¼	15/16	2 ⁷ / ₈	3/8	3/8	5/8	3/16	—	1 ⁵ / ₈	1/2	2 ⁵ / ₁₆	2½	2½	6 ¹³ / ₁₆
3¼	1¾	1¼-12	1-14	1½	1.999	5/8	1½	—	3¼	15/16	2¾	3/8	¼	5/8	3/16	—	1 ⁵ / ₈	11/16	2½	2¾	2¾	7 ¹¹ / ₁₆
	1¾	1¼-12	1-14	2	2.374	¾	1½	—	3¾	11/16	3 ¹⁵ / ₃₂	5/8	3/8	1/2	3/16	—	1 ⁷ / ₈	11/16	2 ⁹ / ₁₆	3	3	7 ¹⁵ / ₁₆
4	2	1¾-12	1¼-12	2	2.374	¾	1½	—	3¾	11/16	3 ¹⁵ / ₃₂	5/8	¼	1/2	3/16	—	1 ⁷ / ₈	11/16	2¾	3	3	8 ³ / ₁₆
	2½	2¼-12	1¾-12	3	3.124	1	2½	—	5¼	2¾	4¼	5/8	3/8	5/8	¼	—	2¼	11/16	3½	3¾	3¾	8 ⁹ / ₁₆
5	2	1¾-12	1¼-12	2	2.374	¾	1½	—	4¼	15/16	3 ²³ / ₃₂	5/8	¼	1/2	3/16	—	2	1	2¾	3½	3½	9 ¹ / ₁₆
	2½	2¼-12	1¾-12	3	3.124	1	2½	—	5¼	3¾	4¼	5/8	3/8	5/8	¼	—	2¼	1	3½	3¾	3¾	9 ⁵ / ₁₆
6	3	2¾-12	2¼-12	3½	3.749	1	2 ⁵ / ₈	—	5¾	2¾	5 ⁷ / ₁₆	7/8	3/8	5/16	—	—	2¼	1	3½	3¾	3¾	9 ⁵ / ₁₆
	3½	3¼-12	2½-12	3½	4.249	1	3	—	5¾	2¾	5 ¹⁵ / ₁₆	15/16	3/8	5/16	—	—	2¼	1	3½	3¾	3¾	9 ⁵ / ₁₆
6	2½	2¼-12	1¾-12	3	3.124	1	2½	—	5¼	2¾	4¼	5/8	¼	5/8	¼	—	2¼	1¼	3¾	3½	3½	10½
	3	2¾-12	2¼-12	3½	3.749	1	2 ⁵ / ₈	—	5¾	2¾	5 ⁷ / ₁₆	7/8	¼	5/16	—	—	2¼	1¼	3¾	3½	3½	10½
6	3½	3¼-12	2½-12	3½	4.249	1	3	—	5¾	3¾	5 ¹⁵ / ₁₆	15/16	¼	5/16	—	—	2¼	1¼	3¾	3½	3½	10½
	4	3¾-12	3-12	4	4.749	1	3¾	—	6¼	3¾	6 ⁵ / ₁₆	15/16	¼	5/16	—	—	2¼	1¼	3¾	3½	3½	10½

Rod End Dimensions for Bolted Retainers – See Table 2

See gland retainer style chart to determine which bore, rod and mount combinations have this feature.

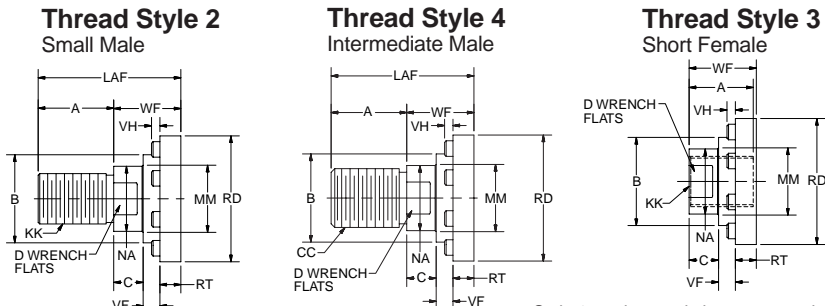

Style 3 stroke restrictions may apply. See Style 3 Minimum Stroke page for details.

A high strength rod end stud is supplied on thread style 2 through 2" diameter rods. Larger sizes or special rod ends are cut threads. Style 2 rod ends are recommended where the workpiece is secured against the rod shoulder. When the workpiece is not shouldered, style 2 rod ends are recommended through 2" piston rod diameters and style 4 rod ends are recommended on larger diameters. Use style 3 for applications where female rod end threads are required. If rod end is not specified, style 2 will be supplied.

"Special" Thread Style 0

Special thread, extension, rod eye, blank, etc., are also available.

To order, specify "Style 0" and give desired dimensions for KK, A and WF. If otherwise special, furnish dimensioned sketch.

B
PL-2
PH-2
PH-3
PHX
SHM
CHE/CHD

Cap Fixed Clevis Mount
NFPA Style MP1

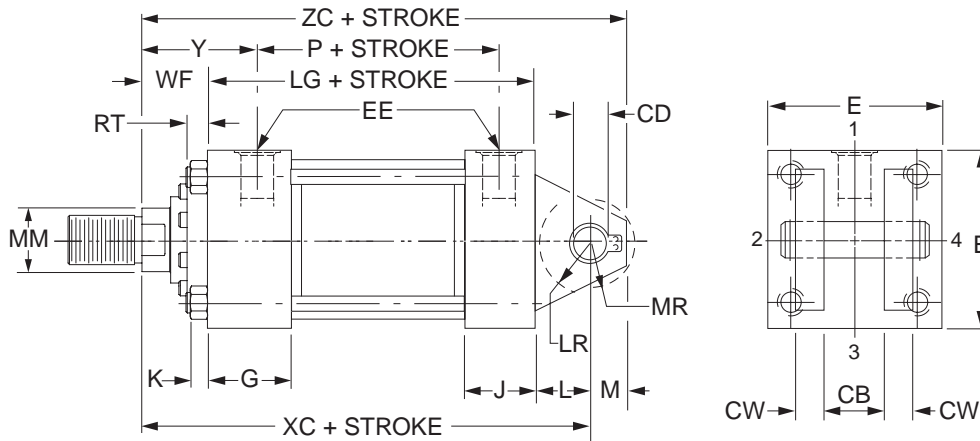
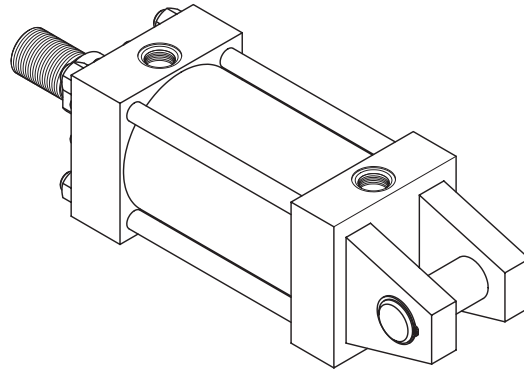

Rod End Dimensions for Full Face Retainers – See Table 2

See gland retainer style chart to determine which bore, rod and mount combinations have this feature.

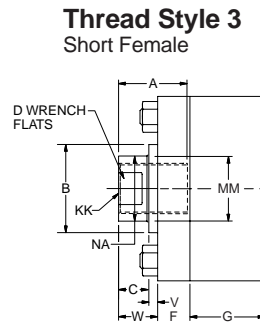
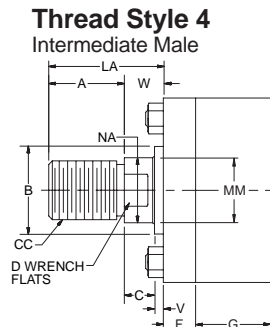
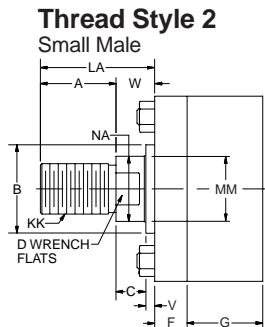

A high strength rod end stud is supplied on thread style 2 through 2" diameter rods. Larger sizes or special rod ends are cut threads. Style 2 rod ends are recommended where the workpiece is secured against the rod shoulder. When the workpiece is not shouldered, style 2 rod ends are recommended through 2"

piston rod diameters and style 4 rod ends are recommended on larger diameters. Use style 3 for applications where female rod end threads are required. If rod end is not specified, style 2 will be supplied.

"Special" Thread Style 0

Special thread, extension, rod eye, blank, etc., are also available.

To order, specify "Style 0" and give desired dimensions for KK, A and W. If otherwise special, furnish dimensioned sketch.

Style 3 stroke restrictions may apply. See Style 3 Minimum Stroke page for details.

Mounting Information – 1½" to 6" Bore

Table 1—Envelope and Mounting Dimensions

Bore	CB	+.000 -.002 CD†	CW	E	EE		F	G	J	K	L	LR	M	MR	Add Stroke	
					NPTF⊕	SAE*									LG	P
1½	¾	.501	½	2½	½	10	¾	1¾	1½	¾	¾	9/16	½	5/8	4⅝	2⅞
2	1¼	.751	5/8	3	½	10	5/8	1¾	1½	7/16	1¼	1	¾	15/16	4⅝	2⅞
2½	1¼	.751	5/8	3½	½	10	5/8	1¾	1½	7/16	1¼	15/16	¾	15/16	4¾	3
3¼	1½	1.001	¾	4½	¾	12	¾	2	1¾	9/16	1½	1¼	1	13/16	5½	3½
4	2	1.376	1	5	¾	12	7/8	2	1¾	9/16	2⅛	1¾	13/8	1⅝	5¾	3¾
5	2½	1.751	1¼	6½	¾	12	7/8	2	1¾	13/16	2¼	2⅛	1¾	2⅛	6¼	4¼
6	2½	2.001	1¼	7½	1	16	1	2¼	2¼	7/8	2½	2⅝	2	2⅝	7⅝	4⅞

* SAE straight thread ports are standard and are indicated by port number.

⊕ NPTF ports are available at no extra charge.

† Dimension CD is pin diameter.

Table 3 —
Envelope and
Mounting Dimensions

Table 2—Rod Dimensions

Bore	Rod Dia. MM	Thread		Rod Extensions and Pilot Dimensions														Add Stroke		
		Style 4 CC	Style 2 & 3 KK & B	A	+.000 -.002 B	C	D	LA	LAF	NA	RD (Max.)	RT	V	VF	VH	W	WF	Y	XC	ZC
1½	5/8	1/2-20	7/16-20	3/4	1.124	3/8	1/2	—	1¾	9/16	115/16	3/8	1/4	1/4	3/16	—	1	2	63/8	67/8
	1	7/8-14	3/4-16	11/8	1.499	1/2	7/8	21/8	21/2	15/16	23/8	3/8	1/2	1/2	3/16	1	13/8	23/8	63/4	71/4
2	1	7/8-14	3/4-16	11/8	1.499	1/2	7/8	—	21/2	15/16	23/8	3/8	1/4	1/2	3/16	—	13/8	23/8	71/4	8
	13/8	1¼-12	1-14	15/8	1.999	5/8	11/8	25/8	3¼	15/16	27/8	3/8	3/8	5/8	3/16	1	15/8	25/8	71/2	8¼
2½	1	7/8-14	3/4-16	11/8	1.499	1/2	7/8	—	21/2	15/16	23/8	3/8	1/4	1/2	3/16	—	13/8	23/8	73/8	81/8
	13/8	1¼-12	1-14	15/8	1.999	5/8	11/8	—	3¼	15/16	27/8	3/8	3/8	5/8	3/16	—	15/8	25/8	75/8	83/8
	1¾	1½-12	1¼-12	2	2.374	3/4	1½	—	37/8	111/16	315/32	5/8	1/2	1/2	3/16	—	17/8	27/8	77/8	85/8
3¼	13/8	1¼-12	1-14	15/8	1.999	5/8	11/8	—	3¼	15/16	27/8	3/8	1/4	5/8	3/16	—	15/8	23/4	85/8	95/8
	1¾	1½-12	1¼-12	2	2.374	3/4	1½	—	37/8	111/16	315/32	5/8	3/8	1/2	3/16	—	17/8	3	87/8	97/8
	2	1¾-12	1½-12	2¼	2.624	7/8	11/16	—	4¼	115/16	323/32	5/8	3/8	1/2	1/4	—	2	31/8	9	10
4	1¾	1½-12	1¼-12	2	2.374	3/4	1½	—	37/8	111/16	315/32	5/8	1/4	1/2	3/16	—	17/8	3	93/4	111/8
	2	1¾-12	1½-12	2¼	2.624	7/8	11/16	—	4¼	115/16	323/32	5/8	1/4	1/2	1/4	—	2	31/8	97/8	11¼
	2½	2¼-12	17/8-12	3	3.124	1	21/16	—	5¼	23/8	4¼	5/8	3/8	5/8	1/4	—	2¼	33/8	107/8	11½
5	2	1¾-12	1½-12	2¼	2.624	7/8	11/16	—	4¼	115/16	323/32	5/8	1/4	1/2	1/4	—	2	31/8	10½	12¼
	2½	2¼-12	17/8-12	3	3.124	1	21/16	—	5¼	33/8	4¼	5/8	3/8	5/8	1/4	—	2¼	33/8	10¾	12½
	3	2¾-12	2¼-12	3½	3.749	1	25/8	—	5¾	27/8	57/16	7/8	3/8	5/16	—	—	2¼	33/8	10¾	12½
	3½	3¼-12	2½-12	3½	4.249	1	3	—	5¾	23/8	515/16	15/16	3/8	5/16	—	—	2¼	33/8	10¾	12½
6	2½	2¼-12	17/8-12	3	3.124	1	21/16	—	5¼	23/8	4¼	5/8	1/4	5/8	1/4	—	2¼	3½	127/8	141/8
	3	2¾-12	2¼-12	3½	3.749	1	25/8	—	5¾	27/8	57/16	7/8	1/4	5/16	—	—	2¼	3½	127/8	141/8
	3½	3¼-12	2½-12	3½	4.249	1	3	—	5¾	33/8	515/16	15/16	1/4	5/16	—	—	2¼	3½	127/8	141/8
	4	3¾-12	3-12	4	4.749	1	33/8	—	6¼	37/8	65/16	15/16	1/4	5/16	—	—	2¼	3½	127/8	141/8

Rod End Dimensions for Bolted Retainers – See Table 2

See gland retainer style chart to determine which bore, rod and mount combinations have this feature.

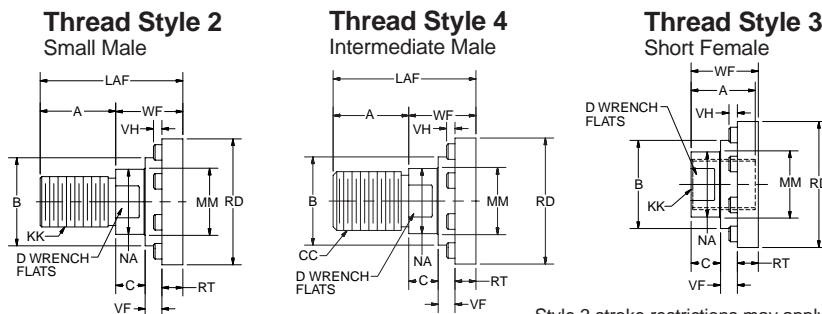

Style 3 stroke restrictions may apply. See Style 3 Minimum Stroke page for details.

A high strength rod end stud is supplied on thread style 2 through 2" diameter rods. Larger sizes or special rod ends are cut threads. Style 2 rod ends are recommended where the workpiece is secured against the rod shoulder. When the workpiece is not shouldered, style 2 rod ends are recommended through 2" piston rod diameters and style 4 rod ends are recommended on larger diameters. Use style 3 for applications where female rod end threads are required. If rod end is not specified, style 2 will be supplied.

“Special” Thread Style 0

Special thread, extension, rod eye, blank, etc., are also available.

To order, specify “Style 0” and give desired dimensions for KK, A and WF. If otherwise special, furnish dimensioned sketch.

**Head Trunnion Mount
NFFPA Style MT1**

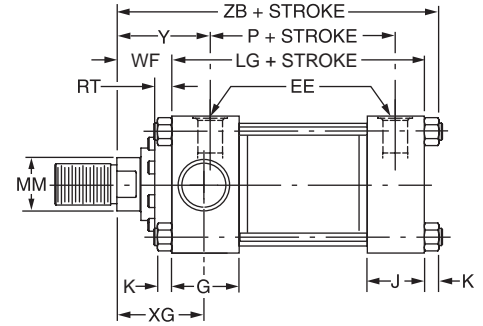
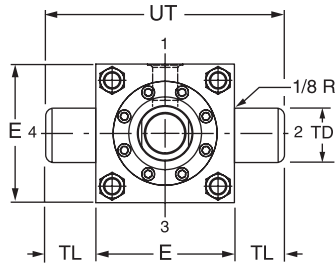
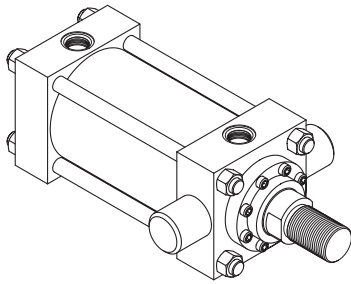

**Cap Trunnion Mount
NFFPA Style MT2**

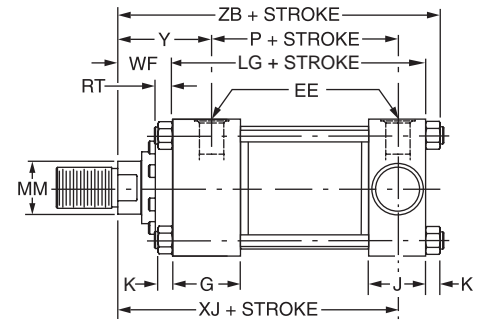
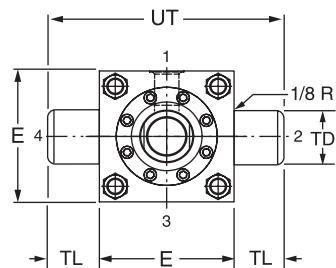
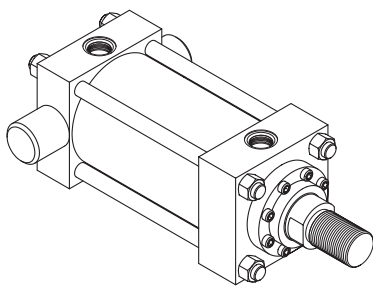

**Intermediate Trunnion Mount
NFFPA Style MT4**

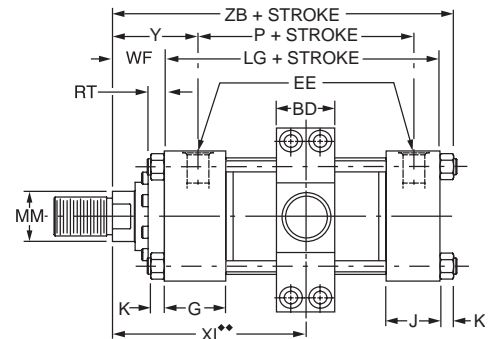
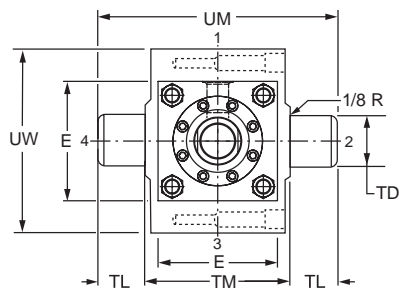
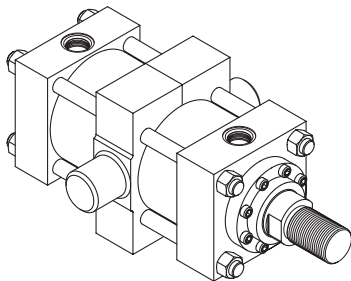

♦♦Dimension XI to be specified by customer.

Rod End Dimensions for Full Face Retainers – See Table 2

See gland retainer style chart to determine which bore, rod and mount combinations have this feature.

**Thread Style 2
Small Male**

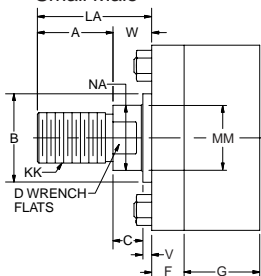

**Thread Style 4
Intermediate Male**

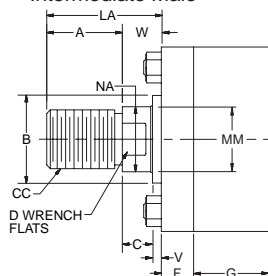

**Thread Style 3
Short Female**

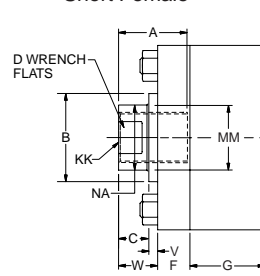

**“Special” Thread
Style 0**

Special thread, extension, rod eye, blank, etc., are also available.

To order, specify “Style 0” and give desired dimensions for KK, A and W. If otherwise special, furnish dimensioned sketch.

Style 3 stroke restrictions may apply. See Style 3 Minimum Stroke page for details.

A high strength rod end stud is supplied on thread style 2 through 2" diameter rods. Larger sizes or special rod ends are cut threads. Style 2 rod ends are recommended where the workpiece is secured against the rod shoulder. When the workpiece is not shouldered, style 2 rod ends are recommended through 2"

piston rod diameters and style 4 rod ends are recommended on larger diameters. Use style 3 for applications where female rod end threads are required. If rod end is not specified, style 2 will be supplied.

Mounting Information – 1½" to 6" Bore

Table 1—Envelope and Mounting Dimensions

Bore	BD	E	EE		F	G	J	K	+0.000 -0.001 TD	TL	TM	UM	UT	UW	Add Stroke		Style MT4 Minimum Stroke
			NPTF [⊖]	SAE ⁺											LG	P	
1½	1¼	2½	½	10	¾	1¾	1½	¾	1.000	1	3	5	4½	3¾	4⅝	2⅞	0
2	1½	3	½	10	⅝	1¾	1½	⅞	1.375	1⅜	3½	6¼	5¾	4⅞	4⅝	2⅞	¼
2½	1½	3½	½	10	⅝	1¾	1½	⅞	1.375	1⅜	4	6¾	6¼	4⅝	4¾	3	⅞
3¼	2	4½	¾	12	¾	2	1¾	⅞	1.750	1¾	5	8½	8	5⅜	5½	3½	¾
4	2	5	¾	12	⅞	2	1¾	⅞	1.750	1¾	5½	9	8½	6⅜	5¾	3¾	⅞
5	2	6½	¾	12	⅞	2	1¾	⅞	1.750	1¾	7	10½	10	7¾	6¼	4¼	0
6	3	7½	1	16	1	2¼	2¼	⅞	2.000	2	8½	12½	11½	10⅜	7⅜	4⅞	¼

* SAE straight thread ports are standard and are indicated by port number.

⊖ NPTF ports are available at no extra charge.

Table 2—Rod Dimensions

Bore	Rod Dia. MM	Thread		Rod Extensions and Pilot Dimensions														Add Stroke				
		Style 4 CC	Style 2 & 3 KK	A	+0.000 -0.002 B	C	D	LA	LAF	NA	RD (Max.)	RT	V	VF	VH	W	WF	XG	Min. XI **	Y	XJ	ZB
1½	⅝	1/2-20	7/16-20	¾	1.124	¾	1/2	—	1¾	9/16	1 ¹⁵ / ₁₆	¾	1/4	1/4	3/16	—	1	1 ⁷ / ₈	3 ⁷ / ₁₆	2	4 ⁷ / ₈	6
	1	7/8-14	3/4-16	1⅞	1.499	1/2	7/8	2⅞	2½	15/16	2 ³ / ₈	¾	1/2	1/2	3/16	1	1 ³ / ₈	2¼	3 ¹³ / ₁₆	2 ³ / ₈	5¼	6 ³ / ₈
2	1	7/8-14	3/4-16	1⅞	1.499	1/2	7/8	—	2½	15/16	2 ³ / ₈	¾	1/4	1/2	3/16	—	1 ³ / ₈	2¼	3 ¹⁵ / ₁₆	2 ³ / ₈	5¼	6 ⁷ / ₁₆
	1⅜	1¼-12	1-14	1⅝	1.999	⅝	1⅞	2⅝	3¼	1 ⁵ / ₁₆	2 ⁷ / ₈	¾	3/8	5/8	3/16	1	1 ⁵ / ₈	2½	4 ³ / ₁₆	2 ⁵ / ₈	5½	6 ¹¹ / ₁₆
2½	1	7/8-14	3/4-16	1⅞	1.499	1/2	7/8	—	2½	15/16	2 ³ / ₈	¾	1/4	1/2	3/16	—	1 ³ / ₈	2¼	3 ¹⁵ / ₁₆	2 ³ / ₈	5 ³ / ₈	6 ⁹ / ₁₆
	1⅜	1¼-12	1¼-12	2	2.374	¾	1½	—	3 ⁷ / ₈	1 ¹¹ / ₁₆	3 ¹⁵ / ₃₂	5/8	1/2	1/2	3/16	—	1 ⁷ / ₈	2 ³ / ₄	4 ⁷ / ₁₆	2 ⁷ / ₈	5 ⁷ / ₈	7 ¹ / ₁₆
3¼	1⅜	1¼-12	1-14	1⅝	1.999	⅝	1⅞	—	3¼	1 ⁵ / ₁₆	2 ⁷ / ₈	¾	1/4	5/8	3/16	—	1 ⁵ / ₈	2 ⁵ / ₈	4 ¹¹ / ₁₆	2 ³ / ₄	6¼	7 ¹¹ / ₁₆
	1⅜	1¼-12	1¼-12	2	2.374	¾	1½	—	3 ⁷ / ₈	1 ¹¹ / ₁₆	3 ¹⁵ / ₃₂	5/8	3/8	1/2	3/16	—	1 ⁷ / ₈	2 ⁷ / ₈	4 ¹⁵ / ₁₆	3	6½	7 ¹⁵ / ₁₆
4	1¾	1½-12	1¼-12	2	2.374	¾	1½	—	4¼	1 ¹⁵ / ₁₆	3 ²³ / ₃₂	5/8	3/8	1/2	1/4	—	2	3	5 ¹ / ₁₆	3 ¹ / ₈	5 ⁵ / ₈	8 ¹ / ₁₆
	2	1¾-12	1½-12	2¼	2.624	⅞	1 ¹¹ / ₁₆	—	4¼	1 ¹⁵ / ₁₆	3 ²³ / ₃₂	5/8	1/4	1/2	1/4	—	2	3	5 ¹ / ₁₆	3 ¹ / ₈	6 ⁷ / ₈	8 ⁵ / ₁₆
5	2½	2¼-12	1⅞-12	3	3.124	1	2 ¹ / ₁₆	—	5¼	2 ³ / ₈	4¼	5/8	3/8	5/8	1/4	—	2¼	3¼	5 ⁵ / ₁₆	3 ³ / ₈	7 ¹ / ₈	8 ⁹ / ₁₆
	2	1¾-12	1½-12	2¼	2.624	⅞	1 ¹¹ / ₁₆	—	4¼	1 ¹⁵ / ₁₆	3 ²³ / ₃₂	5/8	1/4	1/2	1/4	—	2	3	5 ¹ / ₁₆	3 ¹ / ₈	7 ³ / ₈	9 ¹ / ₁₆
6	2½	2¼-12	1⅞-12	3	3.124	1	2 ¹ / ₁₆	—	5¼	2 ³ / ₈	4¼	5/8	1/4	5/8	1/4	—	2¼	3¼	5 ⁵ / ₁₆	3 ³ / ₈	7 ⁵ / ₈	9 ⁵ / ₁₆
	3	2¾-12	2¼-12	3½	3.749	1	2 ⁵ / ₈	—	5¾	2 ⁷ / ₈	5 ⁷ / ₁₆	7/8	3/8	5/16	—	—	2¼	3¼	5 ⁵ / ₁₆	3 ³ / ₈	7 ⁵ / ₈	9 ⁵ / ₁₆
6	2½	2¼-12	1⅞-12	3	3.124	1	2 ¹ / ₁₆	—	5¼	2 ³ / ₈	4¼	5/8	1/4	5/8	1/4	—	2¼	3 ³ / ₈	6 ¹ / ₁₆	3½	8 ³ / ₈	10½
	3	2¾-12	2¼-12	3½	3.749	1	2 ⁵ / ₈	—	5¾	2 ⁷ / ₈	5 ⁷ / ₁₆	7/8	1/4	5/16	—	—	2¼	3 ³ / ₈	6 ¹ / ₁₆	3½	8 ³ / ₈	10½
6	3½	3¼-12	2½-12	3½	4.249	1	3	—	5¾	3 ³ / ₈	5 ¹⁵ / ₁₆	15/16	1/4	5/16	—	—	2¼	3 ³ / ₈	6 ¹ / ₁₆	3½	8 ³ / ₈	10½
	4	3¾-12	3-12	4	4.749	1	3 ³ / ₈	—	6¼	3 ⁷ / ₈	6 ⁵ / ₁₆	15/16	1/4	5/16	—	—	2¼	3 ³ / ₈	6 ¹ / ₁₆	3½	8 ³ / ₈	10½

Rod End Dimensions for Bolted Retainers – See Table 2

See gland retainer style chart to determine which bore, rod and mount combinations have this feature.

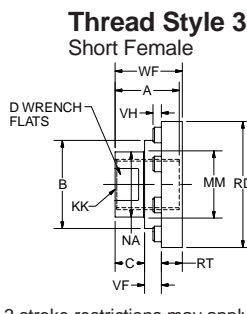
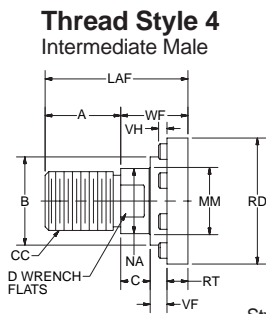
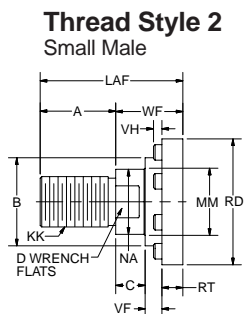

Style 3 stroke restrictions may apply. See Style 3 Minimum Stroke page for details.

A high strength rod end stud is supplied on thread style 2 through 2" diameter rods. Larger sizes or special rod ends are cut threads. Style 2 rod ends are recommended where the workpiece is secured against the rod shoulder. When the workpiece is not shouldered, style 2 rod ends are recommended through 2" piston rod diameters and style 4 rod ends are recommended on larger diameters. Use style 3 for applications where female rod end threads are required. If rod end is not specified, style 2 will be supplied.

“Special” Thread Style 0

Special thread, extension, rod eye, blank, etc., are also available.

To order, specify “Style 0” and give desired dimensions for KK, A and WF. If otherwise special, furnish dimensioned sketch.

Mounting Information – 1½" to 6" Bore

Spherical Bearing Mounting – Style MPU3

Bore Ø	Maximum Operating psi ¹
1.50	1500
2.00	2200
2.50	1450
3.25	1500
4.00	1850
5.00	2000
6.00	1800

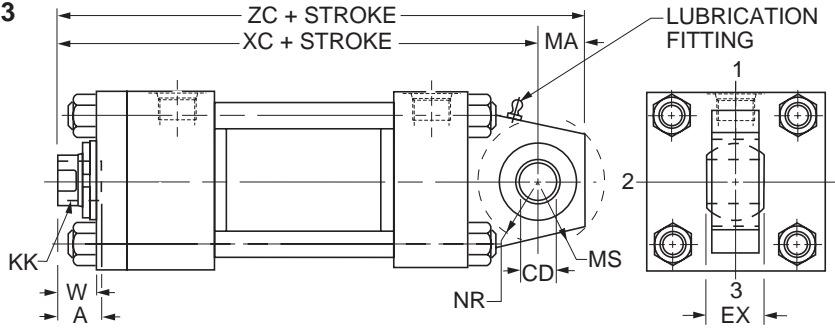

Table 1 — Dimensional and Mounting Data

Bore Ø	Rod No.	MM Rod Ø	Thread		A	CD ² Ø	EX	MA	MS	NR	W	Add Stroke		
			Style 9 KK ³	Style 7 KK ³								XC	ZC	
1.50	1 (Std.)	0.625	7/16-20	—	0.75	-.0005	0.44	0.75	0.94	0.63	0.63	6.38	7.13	
	2	1.000	—	7/16-20	0.75	.5000						1.00	6.75	7.50
2.00	1 (Std.)	1.000	3/4-16	—	1.13	-.0005	0.66	1.00	1.38	1.00	0.75	7.25	8.25	
	2	1.375	—	3/4-16	1.13	.7500						1.00	7.50	8.50
2.50	1 (Std.)	1.000	3/4-16	—	1.13	-.0005	0.66	1.00	1.38	1.00	0.75	7.38	8.38	
	2	1.750	—	3/4-16	1.13							1.25	7.88	8.88
	3	1.375	—	3/4-16	1.13							1.00	7.63	8.63
3.25	1 (Std.)	1.375	1-14	—	1.63	-.0005	0.88	1.25	1.69	1.25	0.88	8.63	9.88	
	2	2.000	—	1-14	1.63							1.25	9.00	10.25
	3	1.750	—	1-14	1.63							1.13	8.88	10.13
4.00	1 (Std.)	1.750	1 1/4-12	—	2.00	-.0005	1.19	1.88	2.44	1.63	1.00	9.75	11.63	
	2	2.500	—	1 1/4-12	2.00							1.38	10.13	12.00
	3	2.000	—	1 1/4-12	2.00							1.13	9.88	11.75
5.00	1 (Std.)	2.000	1 1/2-12	—	2.25	-.0005	1.53	2.50	2.88	2.06	1.13	10.50	13.00	
	2	3.500	—	1 1/2-12	2.25							1.38	10.75	13.25
	3	2.500	—	1 1/2-12	2.25							1.38	10.75	13.25
	4	3.000	—	1 1/2-12	2.25							1.38	10.75	13.25
6.00	1 (Std.)	2.500	1 7/8-12	—	3.00	-.0005	1.75	2.50	3.31	2.38	1.25	12.13	14.63	
	2	4.000	—	1 7/8-12	3.00							1.25	12.13	14.63
	3	3.000	—	1 7/8-12	3.00							1.25	12.13	14.63
	4	3.500	—	1 7/8-12	3.00							1.25	12.13	14.63

Note: for additional dimensions see Series PH-2 NFPA MP1 mount.

¹ Maximum operating pressure at 4:1 design factor is based on tensile strength of material. Pressure ratings are based on standard commercial bearing ratings.

² Dimension "CD" is hole diameter.

³ Threads listed are also for a spherical rod eye which match style 9 or style 7. The spherical rod eye pin diameter matches the cap pin and (if required) needs to be purchased separately; see PH-2 mounting accessories for detailed information.

Mounting Information

Recommended maximum swivel angle on each side of the cylinder centerline.

Head End Mounting

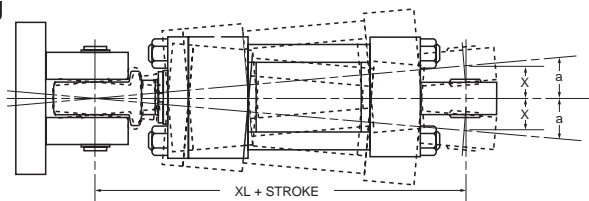

Cap End Mounting

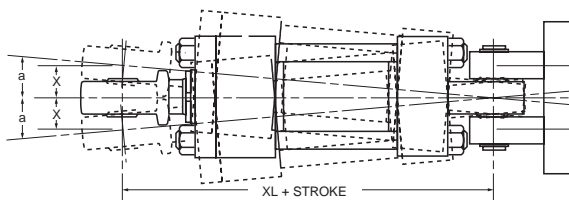

Bore	Head End Mounted		Cap End Mounted	
	Angle a	Tan. of a	Angle a	Tan. of a
1½	2°	.035	2°	.035
2	2½°	.044	4½°	.079
2½	2½°	.044	4½°	.079
3¼	3°	.052	3°	.052
4	2½°	.044	3°	.052
5	3°	.052	3°	.052
6	3°	.052	3°	.052

Note: Dimension X is the maximum off center mounting of the cylinder. To determine dimension X for various stroke lengths multiply the distance between pivot pin holes by tangent of angle a. For extended position use X = XL + 2X stroke.

Schrader Bellows offers a complete range of Cylinder Accessories to assure you of the greatest versatility in present or future cylinder applications. Accessories offered

for the respective cylinder include the Rod Eye, Pivot Pin and Clevis Bracket. To select the proper part number for any desired accessory refer to the charts below.

Spherical Rod Eye

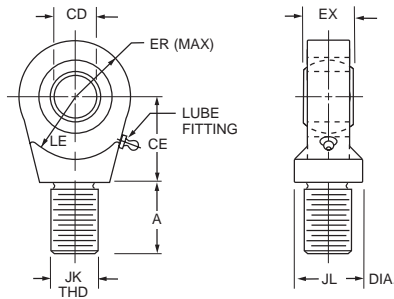

Bore Sizes	PH-2 Series	1 1/2	2 & 2 1/2	3 1/4	4	5	6
Rod Eye	Part No.	1322900000	1322910000	1322920000	1322930000	1322940000	1322950000
	CD	.5000-.0005	.7500-.0005	1.0000-.0005	1.3750-.0005	1.7500-.0005	2.0000-.0005
	A	1 1/16	1	1 1/2	2	2 1/8	2 7/8
	CE	7/8	1 1/4	1 7/8	2 1/8	2 1/2	2 3/4
	EX	7/16	2 1/32	7/8	1 3/16	1 17/32	1 3/4
	ER	7/8	1 1/4	1 3/8	1 13/16	2 3/16	2 5/8
	LE	3/4	1 1/16	1 7/16	1 7/8	2 1/8	2 1/2
	JK	7/16-20	3/4-16	1-14	1 1/4-12	1 1/2-12	1 7/8-12
	JL	7/8	1 5/16	1 1/2	2	2 1/4	2 3/4
	LOAD CAPACITY LBS.	2644	9441	16860	28562	43005	70193

Order to fit Piston Rod Thread Size.

Pivot Pin

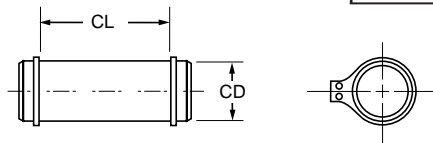

Bore Sizes	PH-2 Series	1 1/2	2 & 2 1/2	3 1/4	4	5	6
Pivot Pin	Part No.	0839620000	0839630000	0839640000	0839650000	0839660000	0839670000
	CD	.4997-.0004	.7497-.0005	.9997-.0005	1.3746-.0006	1.7496-.0006	1.9996-.0007
	CL	1 9/16	2 1/32	2 1/2	3 5/16	4 7/32	4 15/16
	SHEAR CAPACITY LBS.	8600	19300	34300	65000	105200	137400

Pivot Pins are furnished with (2) Retainer Rings.

Clevis Bracket

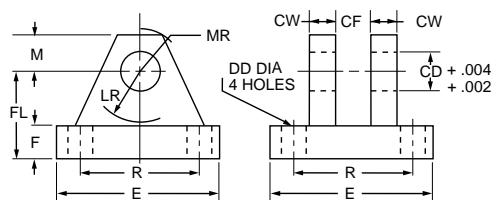

Bore Sizes	PH-2 Series	1 1/2	2 & 2 1/2	3 1/4	4	5	6
Clevis Bracket	Part No.	0839470000	0839480000	0839490000	0839500000	0839510000	0839520000
	CD	1/2	3/4	1	1 3/8	1 3/4	2
	CF	7/16	2 1/32	7/8	1 3/16	1 17/32	1 3/4
	CW	1/2	5/8	3/4	1	1 1/4	1 1/2
	DD	13/32	17/32	17/32	2 1/32	2 9/32	2 9/32
	E	3	3 3/4	5 1/2	6 1/2	8 1/2	10 5/8
	F	1/2	5/8	3/4	7/8	1 1/4	1 1/2
	FL	1 1/2	2	2 1/2	3 1/2	4 1/2	5
	LR	15/16	1 3/8	1 11/16	2 7/16	2 7/8	3 5/16
	M	1/2	7/8	1	1 3/8	1 3/4	2
	MR	5/8	1	1 3/16	1 5/8	2 1/16	2 3/8
	R	2.05	2.76	4.10	4.95	6.58	7.92
	LOAD CAPACITY LBS.	5770	9450	14300	20322	37800	50375

Order to fit Cap or Rod Eye.

How to Use Double Rod Cylinder Dimension Drawings

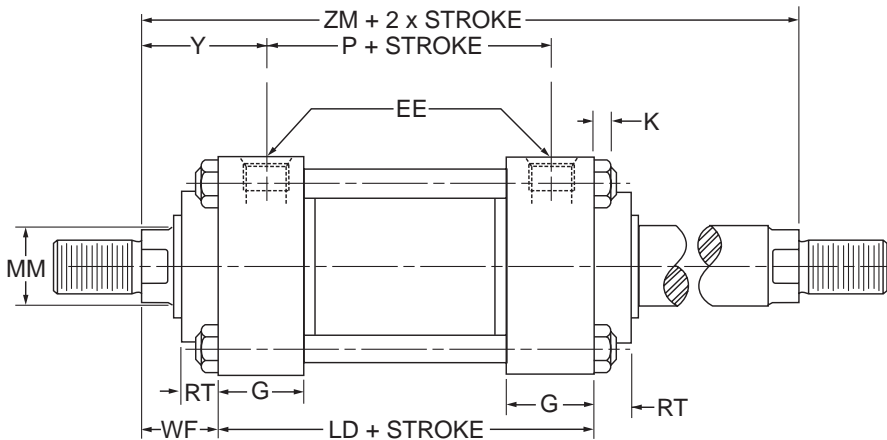

Bore	Rod Dia. MM	Add Stroke			Add 2X Stroke ZM
		LD	Style MDS4 SN	Style MDS2 SS	
1 1/2	5/8	4 7/8	2 7/8	4 1/8	6 7/8
2	1	4 7/8	2 7/8	3 7/8	7 5/8
2 1/2	1	5	3	3 5/8	7 3/4
3 1/4	1 3/8	5 3/4	3 1/2	4 3/8	9
4	1 3/4	6	3 3/4	4 1/4	9 3/4
5	2	6 1/2	4 1/4	4 3/4	10 1/2
6	2 1/2	7 3/8	4 7/8	5 1/8	11 7/8

To determine dimensions for a double rod cylinder, first refer to the desired single rod mounting style cylinder shown on preceding pages of this catalog. After selecting necessary dimensions from that drawing return to this page, supplement the single rod dimensions with those shown on drawing and dimension table. Note that double rod cylinders have a head (Dim. G) at both ends and that dimension LD replaces LG. The double rod dimensions differ from, or are in addition to, those for single rod cylinders shown on preceding pages and provide the information needed to completely dimension a double rod cylinder.

On a double rod cylinder where the two rod ends are different, be sure to clearly state which rod end is to be assembled at which

end. Port position 1 is standard. If other than standard, specify pos. 2, 3 or 4 when viewed from one end only.

All dimensions are in inches and apply to smallest rod sizes only. For alternate rod sizes, determine all envelope dimensions (within LD dim.) as described above and then use appropriate rod end dimensions for proper rod size from single rod cylinder.

Gland Retainer Styles

Bore	Rod Dia.	MX2, MF2, MF6, ME6, MS2, MS4, MT1, MT2, MT4, MP1, MPU3	MX1, MX3	MF1, MF5	ME5
1 1/2	5/8	B	R	R	B
	1	R	R	R	B
2	1	B	R	R	B
	1 3/8	R	R	R	B
2 1/2	1	B	B	B	B
	1 3/8	B	B	B	B
	1 3/4	B	B	R	B
3 1/4	1 3/8	B	B	B	B
	1 3/4	B	B	B	B
	2	B	B	B	B
4	1 3/4	B	B	B	B
	2	B	B	B	B
	2 1/2	B	B	B	B
5	2	B	B	B	B
	2 1/2	B	B	B	B
	3	B	B	B	B
6	3 1/2	B	B	R	B
	2 1/2	B	B	B	B
	3	B	B	B	B
	3 1/2	B	B	B	B
	4	B	B	B	B

The chart at left specifies the gland retainer construction – Bolted Retainer or Full Face Retainer – that will be supplied based on the bore, rod diameter and mounting combination selected in the cylinder model number.

Rod Gland Construction
 B = Bolted Retainer
 R = Full Face Retainer

Linear Alignment Couplers are available in 12 standard thread sizes...

Cost Saving Features and Benefits Include:

- Maximum reliability for trouble-free operation, long life and lower operating costs
- Increased cylinder life by reducing wear on piston and rod bearings
- Simplified cylinder installation and reduced assembly costs
- Increased rod bearing and rod seal life for lower maintenance costs

Alignment Coupler

See Table 1 for Part Numbers and Dimensions

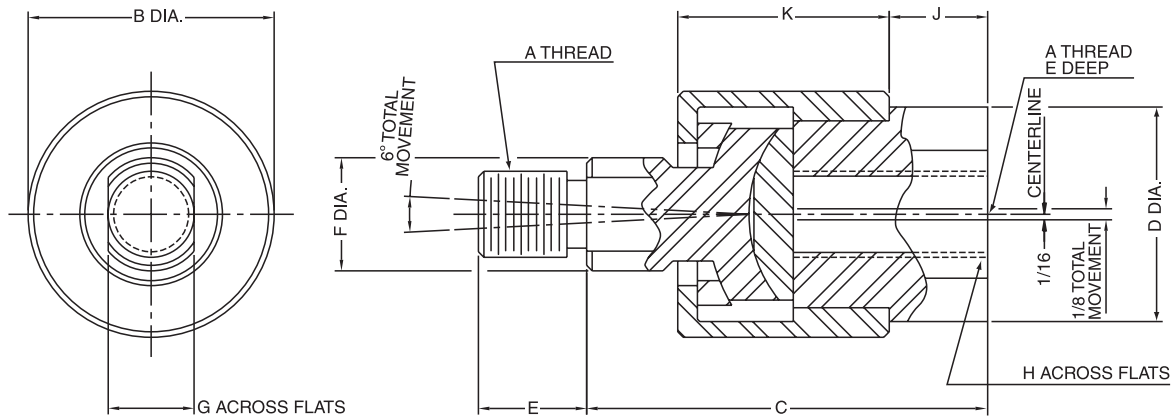

Table 1 — Part Numbers and Dimensions

Part No.	A	B	C	D	E	F	G	H	J	K	Max. Pull Load (lbs.)	Approx. Weight (lbs.)
1347570031	5/16-24	1 1/8	1 3/4	15/16	1/2	1/2	3/8	3/4	3/8	15/16	1200	.35
1347570038	3/8-24	1 1/8	1 3/4	15/16	1/2	1/2	3/8	3/4	3/8	15/16	2425	.35
1347570044	7/16-20	1 3/8	2	1 1/8	3/4	5/8	1/2	7/8	3/8	1 3/32	3250	.55
1347570050	1/2-20	1 3/8	2	1 1/8	3/4	5/8	1/2	7/8	3/8	1 3/32	4450	.55
1347570063	5/8-18	1 3/8	2	1 1/8	3/4	5/8	1/2	7/8	3/8	1 3/32	6800	.55
1347570075	3/4-16	2	2 5/16	1 5/8	1 1/8	15/16	3/4	1 5/16	7/16	1 9/32	9050	1.4
1347570088	7/8-14	2	2 5/16	1 5/8	1 1/8	15/16	3/4	1 5/16	7/16	1 9/32	14450	1.4
1347570100	1-14	3 1/8	3	2 3/8	1 5/8	1 7/16	1 1/4	1 7/8	3/4	1 25/32	19425	4.8
1347570125	1 1/4-12	3 1/8	3	2 3/8	1 5/8	1 7/16	1 1/4	1 7/8	3/4	1 25/32	30500	4.8
1337390125	1 1/4-12	3 1/2	4	2	2	1 1/2	1 1/4	1 11/16	3/4	2 1/2	30500	6.9
1337390150	1 1/2-12	4	4 3/8	2 1/4	2 1/4	1 3/4	1 1/2	1 15/16	7/8	2 3/4	45750	9.8
1337390175	1 3/4-12	4	4 3/8	2 1/4	2 1/4	1 3/4	1 1/2	1 15/16	7/8	2 3/4	58350	9.8
1337390188	1 7/8-12	5	5 5/8	3	3	2 1/4	1 15/16	2 5/8	1 3/8	3 3/8	67550	19.8

How to Order Linear Alignment Couplers — When ordering a cylinder with a threaded male rod end, specify the coupler of equal thread size by part number as listed in Table 1, i.e.; Piston Rod "KK" dimension is 3/4" - 16", specify coupler part number 1347570075.

Cylinder Accessories

Schrader Bellows offers a complete range of cylinder accessories to assure you of the greatest versatility in present and future cylinder applications.

Rod End Accessories

Accessories offered for the rod end of the cylinder include Rod Clevis, Eye Bracket, Knuckle, Clevis Bracket, and Pivot Pin. To select the proper part number for any desired accessory, refer to the table below or on the opposite page and look in the row to the right of the rod thread in the first column. For economical accessory selection, it is recommended that rod end style 2 be specified on your cylinder order.

Accessory Load Capacity

The various accessories have been load rated for your convenience. The load Capacity in lbs. is the recommended maximum load for that accessory based on a 4:1 design factor in tension. (Pivot Pin is rated in shear.) Before specifying, compare the actual load or the tension (pull) force at maximum operating pressure of the cylinder with the load capacity of the accessory you plan to use. If load or pull force of cylinder exceeds load capacity of accessory, consult factory.

Thread Size	Rod Clevis		Mounting Plate or Eye Bracket		Pivot Pin	
	Part Number	Load Capacity (Lbs.)	Part Number	Load Capacity (Lbs.)	Part Number	Shear Capacity (Lbs.)
5/16-24	0512210000†	2600	0740770000	1700	—	—
7/16-20	0509400000	4250	0691950000	4100	0683680000	8600
1/2-20	0509410000	4900	0691950000	4100	0683680000	8600
3/4-16	0509420000	11200	0691960000	10500	0683690000	19300
3/4-16	1332840000	11200	0691960000	10500	0683690000	19300
7/8-14	0509430000	18800	*0853610000	20400	0683700000	34300
1-14	0509440000	19500	*0853610000	20400	0683700000	34300
1-14	1332850000	19500	*0853610000	20400	0683700000	34300
1 1/4-12	0509450000	33500	0691980000	21200	0683710000	65000
1 1/4-12	1332860000	33500	0691980000	21200	0683710000	65000
1 1/2-12	0509460000	45600	*0853620000	49480	0683720000	105200
1 3/4-12	0509470000	65600	*0853630000	70000	0683730000	137400
1 7/8-12	0509480000	65600	*0853630000	70000	0683730000	137400
2 1/4-12	0509490000	98200	*0853640000	94200	0683740000	214700
2 1/2-12	0509500000	98200	*0853650000	121900	0683750000	309200
2 3/4-12	0509510000	98200	*0853650000	121900	0683750000	309200
3 1/4-12	0509520000	156700	0735380000	57400	0735450000	420900
3 1/2-12	0509530000	193200	0735390000	75000	0735470000	565800
4-12	0509540000	221200	0735390000	75000	0735470000	565800

† Includes pivot pin.

* Cylinder accessory dimensions conform to NFPA recommended standard NFPA/T3.6.8 R1-1984, NFPA recommended standard fluid power systems – cylinder – dimensions for accessories for cataloged square head industrial cylinders.

Rod Clevis Dimensions

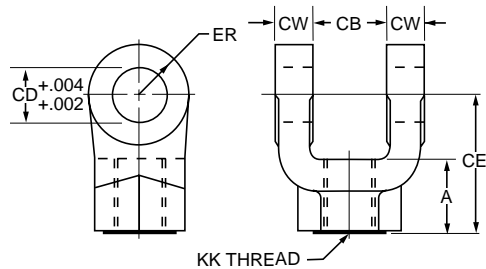

Pivot Pin Dimensions

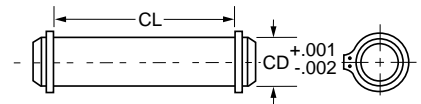

Part Number	A	CB	CD	CE	CW	ER	KK
0512210000†	13/16	11/32	5/16	2 1/4	13/64	19/64	5/16-24
0509400000	3/4	3/4	1/2	1 1/2	1/2	1/2	7/16-20
0509410000	3/4	3/4	1/2	1 1/2	1/2	1/2	1/2-20
0509420000	1 1/8	1 1/4	3/4	2 1/8	5/8	3/4	3/4-16
1332840000	1 1/8	1 1/4	3/4	2 3/8	5/8	3/4	3/4-16
0509430000	1 5/8	1 1/2	1	2 15/16	3/4	1	7/8-14
0509440000	1 5/8	1 1/2	1	2 15/16	3/4	1	1-14
1332850000	1 5/8	1 1/2	1	3 1/8	3/4	1	1-14
0509450000	1 7/8	2	1 3/8	3 3/4	1	1 3/8	1 1/4-12
1332860000	2	2	1 3/8	4 1/8	1	1 3/8	1 1/4-12
0509460000	2 1/4	2 1/2	1 3/4	4 1/2	1 1/4	1 3/4	1 1/2-12
0509470000	3	2 1/2	2	5 1/2	1 1/4	2	1 3/4-12
0509480000	3	2 1/2	2	5 1/2	1 1/4	2	1 7/8-12
0509490000	3 1/2	3	2 1/2	6 1/2	1 1/2	2 1/2	2 1/4-12
0509500000	3 1/2	3	3	6 3/4	1 1/2	2 3/4	2 1/2-12
0509510000	3 1/2	3	3	6 3/4	1 1/2	2 3/4	2 3/4-12
0509520000	3 1/2‡	4	3 1/2	7 3/4	2	3 1/2	3 1/4-12
0509530000	4‡	4 1/2	4	8 13/16	2 1/4	4	3 1/2-12
0509540000	4‡	4 1/2	4	8 13/16	2 1/4	4	4-12

Part Number	CD	CL
0683680000	1/2	1 7/8
0683690000	3/4	2 5/8
0683700000	1	3 1/8
0683710000	1 3/8	4 1/8
0683720000	1 3/4	5 3/16
0683730000	2	5 3/16
0683740000	2 1/2	6 3/16
0683750000	3	6 1/4
0735450000	3 1/2	8 1/4
0735470000*	4	9

* This size supplied with cotter pins.

1. Pivot Pins are furnished with Clevis Mounted Cylinders as standard.
2. Pivot Pins are furnished with (2) Retainer Rings.
3. Pivot Pins must be ordered as a separate item if to be used with Knuckles, Rod Clevises, or Clevis Brackets.

† Includes Pivot Pin

‡ Consult appropriate cylinder rod end dimensions for compatibility.

Mounting Plate or Eye Bracket Dimensions

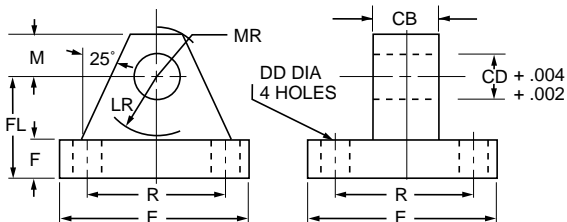

1. When used to mate with the Rod Clevis, select by thread size in table on opposite page.
2. When used to mount the Style MP1 Cylinders, select by bore size below.

Part Number	CB	CD	DD	E	F	FL	LR	M	MR	R	Bore
0740770000	5/16	5/16	17/64	2 1/4	3/8	1	5/8	3/8	1/2	1.75	-
0691950000	3/4	1/2	13/32	2 1/2	3/8	1 1/8	3/4	1/2	9/16	1.63	1 1/2"
0691960000	1 1/4	3/4	17/32	3 1/2	5/8	1 7/8	1 1/4	3/4	7/8	2.55	2", 2 1/2"
*0853610000	1 1/2	1	21/32	4 1/2	7/8	2 3/8	1 1/2	1	1 1/4	3.25	3 1/4"
0691980000	2	1 3/8	21/32	5	7/8	3	2 1/8	1 3/8	1 5/8	3.82	4"
*0853620000	2 1/2	1 3/4	29/32	6 1/2	1 1/8	3 3/8	2 1/4	1 3/4	2 1/8	4.95	5"
*0853630000	2 1/2	2	1 1/16	7 1/2	1 1/2	4	2 1/2	2	2 7/16	5.73	6"
*0853640000	3	2 1/2	1 3/16	8 1/2	1 3/4	4 3/4	3	2 1/2	3	6.58	-
*0853650000	3	3	1 5/16	9 1/2	2	5 1/4	3 1/4	2 3/4	3 1/4	7.50	-
0735380000	4	3 1/2	1 13/16	12 5/8	1 11/16	5 11/16	4	3 1/2	4 1/8	9.62	-
0735390000	4 1/2	4	2 1/16	14 7/8	1 15/16	6 7/16	4 1/2	4	5 1/4	11.45	-

* Cylinder accessory dimensions conform to NFPA recommended standard NFPA/T3.6.8 R1-1984, NFPA recommended standard fluid power systems - cylinder - dimensions for accessories for cataloged square head industrial cylinders.

Rod End Accessories

Accessories offered for the rod end of the cylinder include Rod Clevis, Eye Bracket, Knuckle, Clevis Bracket, and Pivot Pin. To select the proper part number for any desired accessory, refer to the table below or on the opposite page and look in the row to the right of the rod thread in the first column. For economical accessory selection, it is recommended that rod end style 2 be specified on your cylinder order.

Accessory Load Capacity

The various accessories have been load rated for your convenience. The load Capacity in lbs. is the recommended maximum load for that accessory based on a 4:1 design factor in tension. (Pivot Pin is rated in shear.) Before specifying, compare the actual load or the tension (pull) force at the maximum operating pressure of the cylinder with the load capacity of the accessory you plan to use. If load or pull force of cylinder exceeds load capacity of accessory, consult factory.

Thread Size	Knuckle		Clevis Bracket		Pivot Pin	
	Part Number	Load Capacity (Lbs.)	Part Number	Load Capacity (Lbs.)	Part Number	Shear Capacity (Lbs.)
5/16-24	0740750000	3300	0740760000	3600	0740780000	6600
7/16-20	0690890000	5000	0692050000	7300	0683680000	8600
1/2-20	0690900000	5700	0692050000	7300	0683680000	8600
3/4-16	0690910000	12100	0692060000	14000	0683690000	19300
7/8-14	0690920000	13000	0692070000	19200	0683700000	34300
1-14	0690930000	21700	0692070000	19200	0683700000	34300
1 1/4-12	0690940000	33500	0692080000	36900	0683710000	65000
1 1/2-12	0690950000	45000	0692090000	34000	0683720000	105200
1 3/4-12	0690960000	53500	0692100000	33000	0692150000	137400
1 7/8-12	0690970000	75000	0692100000	33000	0692150000	137400
2 1/4-12	0690980000	98700	0692110000	34900	0683740000	214700
2 1/2-12	0690990000	110000	0692120000	33800	0683750000	309200
2 3/4-12	0691000000	123300	0692130000	36900	0692160000	309200
3 1/4-12	0735360000	161300	0735420000	83500	0735450000	420900
3 1/2-12	0734370000	217300	0735420000	83500	0735450000	420900
4-12	0734380000	273800	0735430000	102600	0821810000	565800
4 1/2-12	0734390000	308500	0735440000	108400	0735470000•	565800

- This size supplied with cotter pins.

Knuckle Dimensions

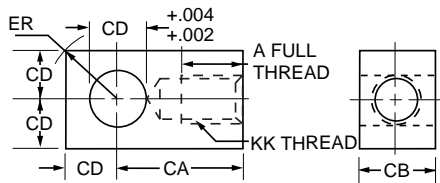

Pivot Pin Dimensions

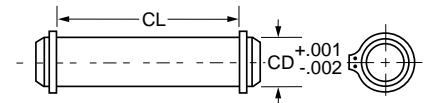

Part Number	A	CA	CB	CD	ER	KK
0740750000	3/4	1 1/2	7/16	7/16	19/32	5/16-24
0690890000	3/4	1 1/2	3/4	1/2	23/32	7/16-20
0690900000	3/4	1 1/2	3/4	1/2	23/32	1/2-20
0690910000	1 1/8	2 1/16	1 1/4	3/4	1 1/16	3/4-16
0690920000	1 1/8	2 3/8	1 1/2	1	1 7/16	7/8-14
0690930000	1 5/8	2 13/16	1 1/2	1	1 7/16	1-14
0690940000	2	3 7/16	2	1 3/8	1 31/32	1 1/4-12
0690950000	2 1/4	4	2 1/2	1 3/4	2 1/2	1 1/2-12
0690960000	2 1/4	4 3/8	2 1/2	2	2 27/32	1 3/4-12
0690970000	3	5	2 1/2	2	2 27/32	1 7/8-12
0690980000	3 1/2	5 13/16	3	2 1/2	3 9/16	2 1/4-12
0690990000	3 1/2	6 1/8	3	3	4 1/4	2 1/2-12
0691000000	3 5/8	6 1/2	3 1/2	3	4 1/4	2 3/4-12
0735360000	4 1/2	7 5/8	4	3 1/2	4 31/32	3 1/4-12
0734370000	5	7 5/8	4	3 1/2	4 31/32	3 1/2-12
0734380000	5 1/2	9 1/8	4 1/2	4	5 11/16	4-12
0734390000	5 1/2	9 1/8	5	4	5 11/16	4 1/2-12

Part Number	CD	CL
0740780000	7/16	1 5/16
0683680000	1/2	1 7/8
0683690000	3/4	2 5/8
0683700000	1	3 1/8
0683710000	1 3/8	4 1/8
0683720000	1 3/4	5 3/16
0692150000	2	5 11/16
0683740000	2 1/2	6 3/16
0683750000	3	6 1/4
0692160000	3	6 3/4
0735450000	3 1/2	8 1/4
0821810000	4	8 5/8
0735470000*	4	9

- * This size supplied with cotter pins.
1. Pivot Pins are furnished with Clevis Mounted Cylinders as standard.
 2. Pivot Pins are furnished with (2) Retainer Rings.
 3. Pivot Pins must be ordered as a separate item if to be used with Knuckles, Rod Clevises, or Clevis Brackets.

Clevis Bracket Dimensions

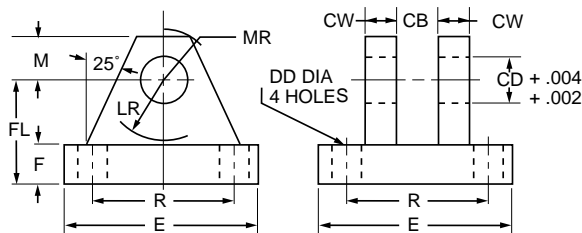

Part Number	CB	CD	CW	DD	E	F	FL	LR	M	MR	R
0740760000	15/32	7/16	3/8	17/64	2 1/4	3/8	1	5/8	3/8	1/2	1.75
0692050000	3/4	1/2	1/2	13/32	3 1/2	1/2	1 1/2	3/4	1/2	5/8	2.55
0692060000	1 1/4	3/4	5/8	17/32	5	5/8	1 7/8	1 3/16	3/4	29/32	3.82
0692070000	1 1/2	1	3/4	21/32	6 1/2	3/4	2 1/4	1 1/2	1	1 1/4	4.95
0692080000	2	1 3/8	1	21/32	7 1/2	7/8	3	2	1 3/8	1 21/32	5.73
0692090000	2 1/2	1 3/4	1 1/4	29/32	9 1/2	7/8	3 5/8	2 3/4	1 3/4	2 7/32	7.50
0692100000	2 1/2	2	1 1/2	1 1/16	12 3/4	1	4 1/4	3 3/16	2 1/4	2 25/32	9.40
0692110000	3	2 1/2	1 1/2	1 3/16	12 3/4	1	4 1/2	3 1/2	2 1/2	3 1/8	9.40
0692120000	3	3	1 1/2	1 5/16	12 3/4	1	6	4 1/4	3	3 19/32	9.40
0692130000	3 1/2	3	1 1/2	1 5/16	12 3/4	1	6	4 1/4	3	3 19/32	9.40
0735420000	4	3 1/2	2	1 13/16	15 1/2	1 11/16	6 11/16	5	3 1/2	4 1/8	12.00
0735430000	4 1/2	4	2	2 1/16	17 1/2	1 15/16	7 11/16	5 3/4	4	4 7/8	13.75
0735440000	5	4	2	2 1/16	17 1/2	1 15/16	7 11/16	5 3/4	4	4 7/8	13.75

Cylinder accessory dimensions conform to NFPA recommended standard NFPT/T3.6.8 R1-1984, NFPA recommended standard fluid power systems - cylinder - dimensions for accessories for cataloged square head industrial cylinders.

B
 PL-2
 PH-2
 PH-3
 PHX
 SHM
 CHE/CHD

Schrader Bellows "Style 6" Piston Rod End

Rod end flange coupling for Schrader Bellows PH-2 Series Hydraulic Cylinders

- Simplifies alignment
- Reduces assembly time
- Allows full rated hydraulic pressure in push and pull directions

Style 6 Rod End

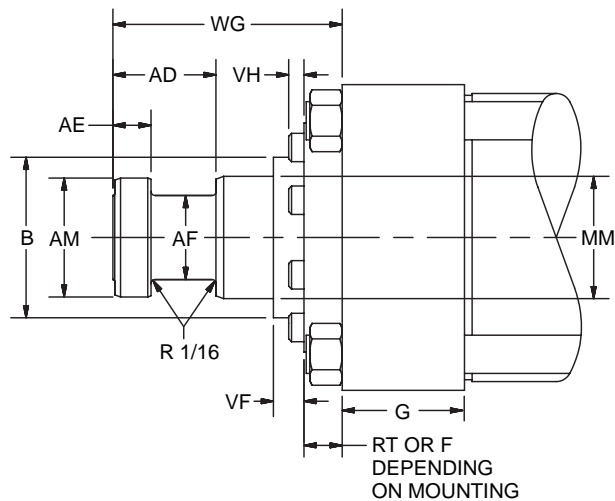

Dimensions Style 6 Rod End

MM Rod Dia.	AD	AE	AF	AM	WG
$\frac{5}{8}$	$\frac{5}{8}$	$\frac{1}{4}$	$\frac{3}{8}$.57	$1\frac{3}{4}$
1	$\frac{15}{16}$	$\frac{3}{8}$	$\frac{11}{16}$.95	$2\frac{3}{8}$
$1\frac{3}{8}$	$\frac{11}{16}$	$\frac{3}{8}$	$\frac{7}{8}$	1.32	$2\frac{3}{4}$
$1\frac{3}{4}$	$\frac{15}{16}$	$\frac{1}{2}$	$1\frac{1}{8}$	1.70	$3\frac{1}{8}$
2	$1\frac{11}{16}$	$\frac{5}{8}$	$1\frac{3}{8}$	1.95	$3\frac{3}{4}$
$2\frac{1}{2}$	$1\frac{15}{16}$	$\frac{3}{4}$	$1\frac{3}{4}$	2.45	$4\frac{1}{2}$
3	$2\frac{7}{16}$	$\frac{7}{8}$	$2\frac{1}{4}$	2.95	$4\frac{7}{8}$
$3\frac{1}{2}$	$2\frac{11}{16}$	1	$2\frac{1}{2}$	3.45	$5\frac{5}{8}$
4	$2\frac{11}{16}$	1	3	3.95	$5\frac{3}{4}$

See Cylinder Catalog for B, F, G, RT, VF and VH per bore and rod diameter.

Consult Factory for availability of mounting accessories and Hardware.

How To Order

Complete Model Number and place a "6" in the Piston Rod End designator position.

Example: PHEA32165x12.0

Schrader Bellows “Style 6” Piston Rod End

Split Couplers and Weld Plates

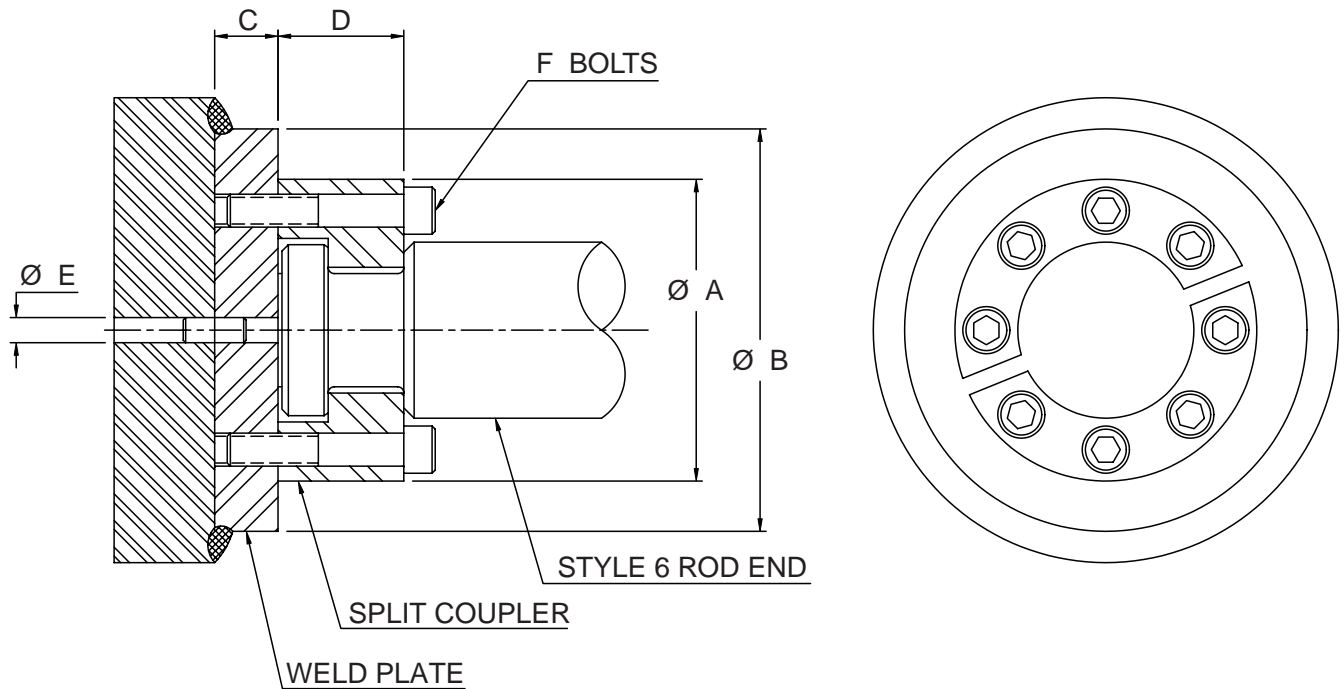

⚠ WARNING: Piston rod separation from the machine member can result in severe personal injury or even death to nearby personnel. The cylinder user must make sure the weld holding the weld plate to the machine is of sufficient quality and size to hold the intended load. The cylinder user must also make sure the bolts holding split coupler to the weld plate are of sufficient strength to hold the intended load and installed in such a way that they will not become loose during the machine's operation.

Table 1 — Part Numbers and Dimensions

Rod Dia.	A	B	C	D	E	F	Bolt Size	Bolt Circle	Split Coupler Part No.	Weld Plate Part No.
5/8	1.50	2.00	.50	.56	.250	4	#10-24 x .94 LG	1.125	1472340062	1481740062
1	2.00	2.50	.50	.88	.250	6	.250-20 x 1.25 LG	1.500	1472340100	1481740100
1 3/8	2.50	3.00	.63	1.00	.250	6	.312-18 x 1.50 LG	2.000	1472340138	1481740138
1 3/4	3.00	4.00	.63	1.25	.250	8	.312-18 x 1.75 LG	2.375	1472340175	1481740175
2	3.50	4.00	.75	1.63	.375	12	.375-16 x 2.25 LG	2.687	1472340200	1481740200
2 1/2	4.00	4.50	.75	1.88	.375	12	.375-16 x 2.50 LG	3.187	1472340250	1481740250
3	5.00	5.50	1.00	2.38	.375	12	.500-13 x 3.25 LG	4.000	1472340300	1481740300
3 1/2	5.88	7.00	1.00	2.63	.375	12	.625-11 x 3.50 LG	4.687	1472340350	1481740350
4	6.38	7.00	1.00	2.63	.375	12	.625-11 x 3.50 LG	5.187	1472340400	1481740400

Note: Screws are not included with split coupler or weld plate.

How to Order PH-2 Series Cylinders

When ordering PH-2 Series cylinders, please review the following:

Note: Duplicate cylinders can be ordered by giving the SERIAL NUMBER from the nameplate of the original cylinder. Factory records supply a quick positive identification.

Piston Rods: Specify model number code based on bore size and rod diameter. Give thread style number for a standard thread or specify dimensions. See "Style 0 Rod End" below.

Cushions: If cushions are required specify according to the model number on the next page. If the cylinder is to have a double rod and only one cushion is required, be sure to specify clearly which end of the cylinder is to be cushioned.

Special Modifications: Additional information is required on orders for cylinders with special modifications. This is best handled with descriptive notes. For further information, consult factory.

Lipseal™ Piston (if desired): Schrader Bellows Lipseal™ pistons are offered as an option at no extra cost in the PH-2 Series cylinders. With this feature, zero leakage under static holding conditions is attained. Hi Load piston seals are available for an additional charge.

Fluid Medium: PH-2 Series hydraulic cylinders are equipped with seals for use with hydraulic oil. If other than hydraulic oil will be used, specify class of fluid (See Catalog section C.)

Water Service Modifications

When requested, Schrader Bellows can supply PH-2 Series cylinders with standard modifications that make the cylinders suitable for use with water as the fluid medium. The modifications include chrome-plated cylinder bore; electroless nickel-plated, non-wearing internal surfaces; Lipseal style piston, Buna N Seals and chrome-plated, precipitation hardened stainless steel piston rod.

Warranty – Schrader Bellows will warrant Series PH-2 cylinders modified for water or high water content fluid service to be free of defects in materials or workmanship, but cannot accept responsibility for premature failure due to excessive wear resulting from lack of lubricity, where failure is caused by corrosion, electrolysis or mineral deposits within the cylinder.

Class 1 Seals

Class 1 seals are the seals provided as standard in a cylinder assembly unless otherwise specified. For further information on fluid compatibility or operating limitations of all components, see section C.

For the PH-2 series cylinders the following make-up Class 1 Seals:
Primary Piston Rod Seal – Enhanced Polyurethane

Piston Rod Wiper – Nitrile
Piston Seals – Nitrile lipseals with polymyte back-up washers
Option – Nitrile lipseals with polymyte back-up washers
Option – Hi-Load. Filled P.T.F.E. seals with a nitrile expander
O-Rings – Nitrile (nitrile back-up washer when used)

Style 0 Rod End

A style 0 rod end indicates a special rod end configuration. All special piston rod dimensions must have **all three:** KK; A and W/WF specified with the rod fully retracted. A sketch or drawing should be submitted for rod ends requiring special machining such as snap ring grooves, keyways, tapers, multiple diameters, etc. It is good design practice to have this machining done on a diameter at least 0.065 inches smaller than the piston rod diameter. This allows the piston rod to have a chamfer preventing rod seal damage

during assembly or maintenance. Standard style 6 rod ends with a longer than standard WG dimension should call out a style 0 rod end and the note: **same as 6 except WG= ____**. A drawing should be submitted for special 6 rod ends that have specific tolerances or special radii. Special rod ends that have smaller than standard male threads, larger than standard female threads, or style 6 rod ends with smaller than standard AF or AE dimensions are to be reviewed by Engineering for proper strength at operating pressure.

Service Policy

On cylinders returned to the factory for repairs, it is standard policy for the Industrial Cylinder Division to make such part replacements as will put the cylinder in as good as new condition. Should the condition of the returned cylinder be such that expenses for repair would exceed the costs of a new one, you will be notified.

Address all correspondence and make shipments to, Service Department at your nearest regional plant.

Certified Dimensions

Schrader Bellows Industrial Cylinder Division guarantees that all cylinders ordered from this catalog will be built to dimensions shown. All dimensions are certified to be correct, and thus it is not necessary to request certified drawings.

How To Order

How To Order By Model Number

PH-2 Hydraulic Cylinders can be specified by model number by using the tables shown at right.

1. Type

Select the Model Number Code which identifies single, double end and port specification.

2. Bore & Rod Diameter

Select the Model Number Code which identifies the desired bore size and rod diameter combination.

3. Mounting & Cushioning

Select the Model Number Code which identifies the desired mounting style and cushioning option.

4. Rod End Style

Select the Model Number Code which identifies the desired rod end thread style.

5. Seal Type

Complete the Model Number by selecting the type of seals desired. Piston rings standard, Lip Seals optional.

6. Stroke Length

It is necessary to specify the stroke length desired following the Model Number. For example: PHAA00823 with 6" stroke.

Specifying the Desired Trunnion Location

For cylinders with intermediate trunnion mounting, the dimension specified should be the distance from the piston rod reference point to the center-line of the pin.

The Example Would Identify:

A single end hydraulic cylinder, 1-1/2" bore size, 5/8" piston rod diameter, side lug mount, cushioned both ends, with a small male rod thread, Piston Rings with Buna N Seals, a 6" stroke, and S.A.E. Ports.

Optional Mounting Accessories

Specify separately the part number for desired optional mounting accessories.

Note: For special modifications other than piston rod ends use S in the tenth position of the model number and describe special features required.

Example: PHAA00823S 6" Stroke
 Ports to be position 2.

1	Model Number
Type	PH-2 Series Hydraulic
Single Rod End with SAE Straight Thread Ports	PH
Double Rod End with SAE Straight Thread Ports	PJ
Single Rod End with NPTF Ports	PF
Double Rod End with NPTF Ports	PK
Single End with SAE Flange Ports*	PX
Double End with SAE Flange Ports*	PY

*SAE Flange Ports not available in 1 1/2" & 2" bore sizes.

2	Bore Size	Rod Dia.	Model Number Code	Bore Size	Rod Dia.	Model Number Code
1 1/2"	5/8"	AA0	4"	1 3/4"	EA3	
	1"	AA1		2"	EA4	
2"	1"	BA1	5"	2 1/2"	EA5	
	1 3/8"	BA2		2"	FA4	
2 1/2"	1"	CA1	6"	2 1/2"	FA5	
	1 3/8"	CA2		3"	FA6	
	1 3/4"	CA3		3 1/2"	FA7	
3 1/4"	1 3/8"	DA2	6"	2 1/2"	GA5	
	1 3/4"	DA3		3"	GA6	
	2"	DA4		3 1/2"	GA7	
				4"	GA8	

3	Mounting Style	Model Number Code				
		NFPA Style	Non-Cush.	Cush. Head	Cush. Cap	Cush. Both
	Side Lug	MS2	05	06	07	08
	Side Tap	MS4	13	14	15	16
	Head Rectangular Flange	MF1	21	22	23	24
	Cap Rectangular Flange	MF2	25	26	27	28
	Head Square Flange	MF5	29	30	31	32
	Cap Square Flange	MF6	33	34	35	36
	Head Rectangular	ME5	45	46	47	48
	Cap Rectangular	ME6	49	50	51	52
	Tie Rods Extended Both Ends	MX1	53	54	55	56
	Tie Rods Extended Cap End	MX2	57	58	59	60
	Tie Rods Extended Head End	MX3	61	62	63	64
	Head Trunnion	MT1	69	70	71	72
	Cap Trunnion	MT2	73	74	75	76
	Intermediate Fixed Trunnion	MT4	77	78	79	80
	Cap Fixed Clevis	MP1	81	82	83	84
	Spherical Bearing	MPU3	89	90	91	92
	No Mount	MX0	93	94	95	96

4	Rod End Style	Model Number Code
	Small Male	2
	Short Female	3
	Intermediate Male	4
	Flange Coupling	6
	Female Thread for Spherical Rod Eye	7
	Special Specify	0

5	Seal Type**	Model Number Code
	Buna N Seals	1
	Fluorocarbon Seals	2
	Buna N Seals w/Piston Rings	3
	Fluorocarbon Seals w/Piston Rings	4
	Buna N with Hi-Load	5
	Fluorocarbon with Hi-Load	6
	High Water Content	7

6	Specify Stroke Length	6.00"
----------	------------------------------	--------------

Model Number Example:

PH AA0 08 2 3 W/6" Stroke

**Piston Rings are recommended for maximum seal life, but slight hydraulic bypass should be expected.

NOTES



Contents

Features	80	Cylinder Accessories	96-99
Specifications / Mountings	81	"Style 6" Piston Rod End.....	100-101
Mounting Information	82-93	How to Order.....	102-103
Double Rod Cylinders	94	Parts I.D. and Seal Kits.....	Sec. C, pgs. 40-41
Linear Alignment Couplers	95	Application Engineering Data	Sec. C, pgs. 49-85

B

PL-2

PH-2

PH-3

PHX

SHM

CHE/CHD

PH-3 Series 7" and 8" Bore Heavy Duty High Pressure Hydraulic Cylinders

- Bolt-on gland retainer for ease of maintenance.
- Hi-Load piston is standard.
- Cylinder body seal grooves and high-strength tie rods ensure trouble-free performance even in severe applications.
- Floating cushions with float-check action and positive metal-to-metal seal.

Every cylinder is *individually* tested before it leaves our plant. Schrader Bellows meets all of your heavy-duty hydraulic cylinder needs.

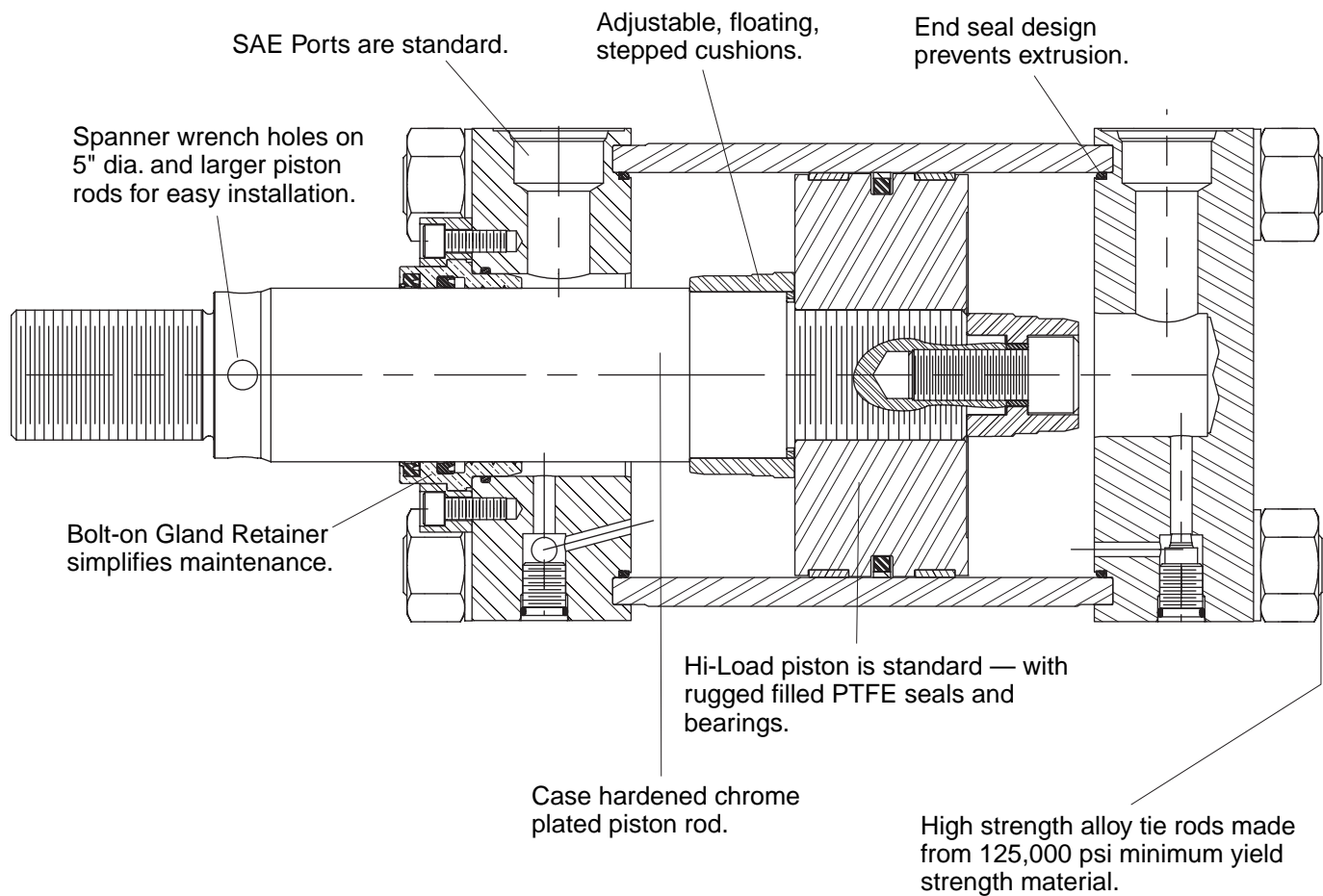

Standard Specifications

- Heavy Duty Service — ANSI/NFPA T.3.6.7R2-1996 specifications and mounting dimension standards
- Standard Construction — Square Head – Tie Rod Design
- Nominal Pressure — 3000 PSI*
- Standard Fluid — Hydraulic Oil
- Standard Temperature — -10° F. to +165° F.
- Piston Rod Diameter — 3" through 5 1/2"

- Mounting Styles — 15 standard styles at various application ratings
- Strokes — Available in any practical stroke length
- Cushions — Optional at either end or both ends of stroke
- Rod Ends — Three Standard Choices — specials to order

*If hydraulic operating pressure exceeds 3000 PSI, send application data for engineering evaluation and recommendation.
In line with our policy of continuing product improvement, specifications in this catalog are subject to change.

Available Mounting Styles

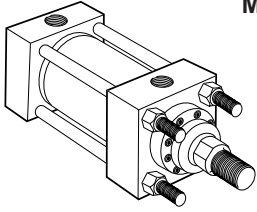
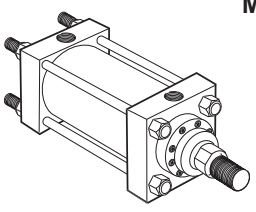
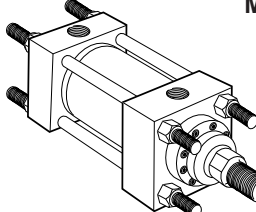
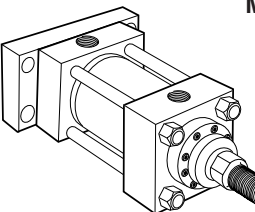
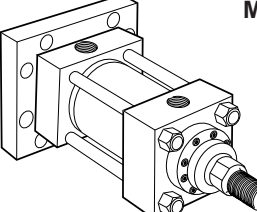
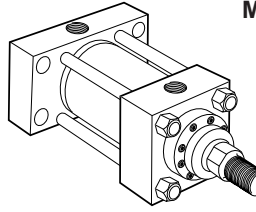
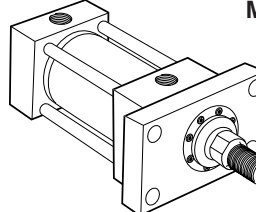
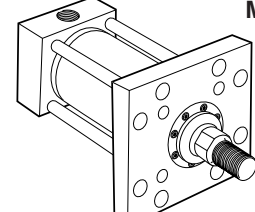
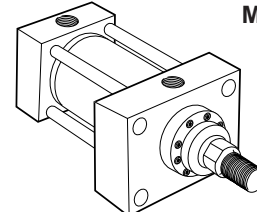
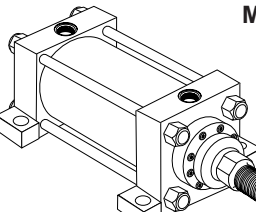
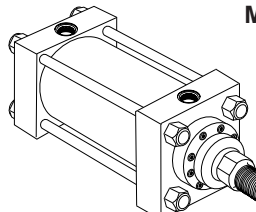
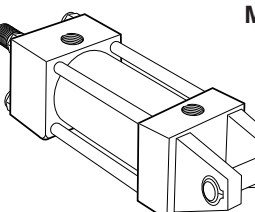
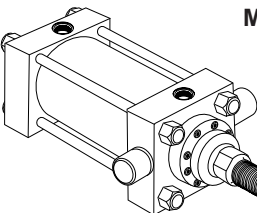
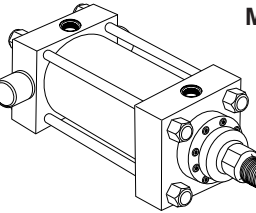
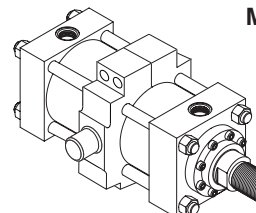
 <p>Model MX3 Tie Rods Extended Head End</p>	 <p>Model MX2 Tie Rods Extended Cap End</p>	 <p>Model MX1 Tie Rods Extended Both Ends</p>	 <p>Model MF2 Cap Rectangular Flange</p>
 <p>Model MF6 Cap Square Flange</p>	 <p>Model ME6 Cap Rectangular</p>	 <p>Model MF1 Head Rectangular Flange</p>	 <p>Model MF5 Head Square Flange</p>
 <p>Model ME5 Head Rectangular</p>	 <p>Model MS2 Side Lug</p>	 <p>Model MS4 Side Tap</p>	 <p>Model MP1 Cap Fixed Clevis</p>
 <p>Model MT1 Head Trunnion</p>	 <p>Model MT2 Cap Trunnion</p>	 <p>Model MT4 Intermediate Fixed Trunnion</p>	<p>Double Rod Cylinders Most of the above illustrated mounting styles are available in double rod cylinders. See double rod page.</p>

B
PL-2
PH-2
PH-3
PHX
SHM
CHE/CHD

**Tie Rods Extended Head End Mount
NFPA Style MX3**

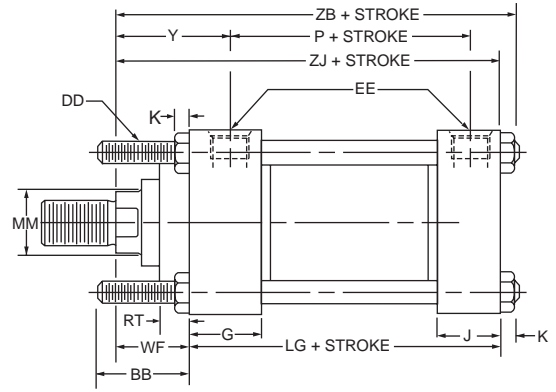
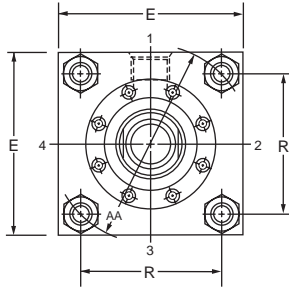
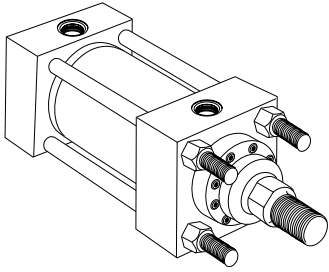

**Tie Rods Extended Cap End Mount
NFPA Style MX2**

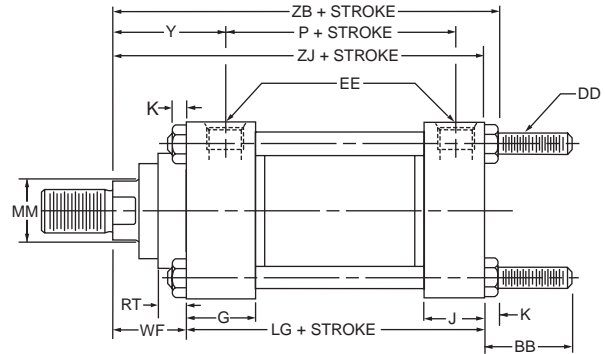
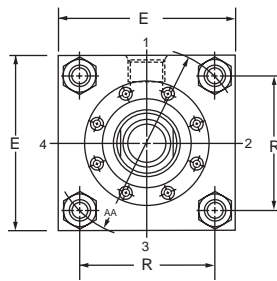
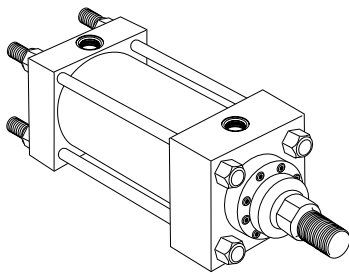

**Tie Rods Extended Both Ends Mount
NFPA Style MX1**

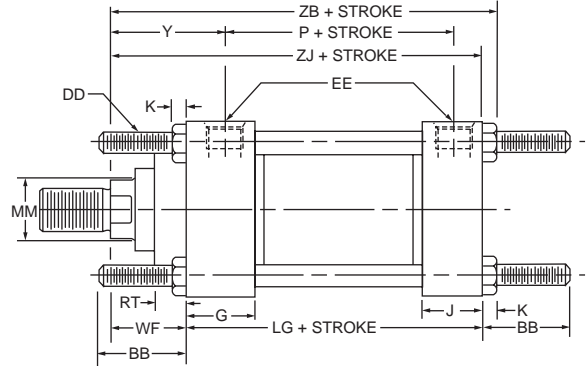
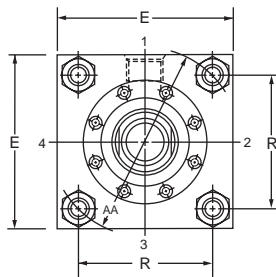
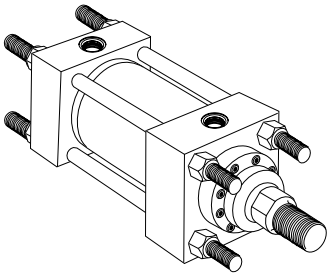

Rod End Dimensions — see Table 2

**Thread Style 2
Small Male**

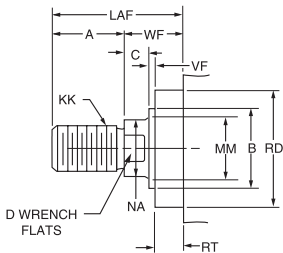

**Thread Style 4
Intermediate Male**

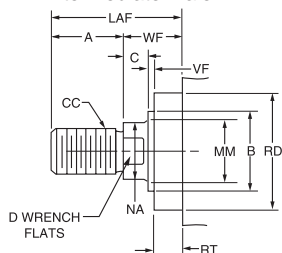

**Thread Style 3
Short Female**

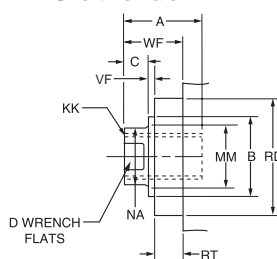

Style 3 stroke restrictions may apply. See Style 3 Minimum Stroke page for details.

“Special” Thread Style 0

Special thread, extension, rod eye, blank, etc., are also available.

To order, specify “Style 0” and give desired dimensions for KK, A and WF. If otherwise special, furnish dimensioned sketch.

Over 2" rod sizes or special rod ends are cut threads. Style 2 rod ends are recommended where the workpiece is secured against the rod shoulder. When the workpiece is not shouldered, style 4 rod ends are recommended over 2" piston rod diameters. Use

style 3 for applications where female rod end threads are required. If rod end is not specified, style 2 will be supplied. On 5" rods and above, (4) .515 dia. spanner wrench holes will be provided instead of wrench flats.

Table 1—Envelope and Mounting Dimensions

Bore	AA	BB	DD	E	EE		G	J	K	R	Add Stroke	
					NPTF [⊖]	SAE*					LG	P
7	9.3	4 ¹ / ₈	1 ¹ / ₈ -12	8 ¹ / ₂	1 ¹ / ₄	20	2 ³ / ₄	2 ³ / ₄	1 ¹ / ₄	6.58	8 ¹ / ₂	5 ¹ / ₂
8	10.6	4 ¹ / ₂	1 ¹ / ₄ -12	9 ¹ / ₂	1 ¹ / ₂	24	3	3	1 ¹ / ₂	7.50	9 ¹ / ₂	6 ¹ / ₄

* SAE straight thread ports are standard and are indicated by port number.

⊖ NPTF ports are available at no extra charge.

Table 2—Rod Dimensions

Bore	Rod Dia. MM	Thread		Rod Extensions and Pilot Dimensions										Add Stroke		
		Style 4 CC	Style 2 & 3 KK	A	+0.000 -.002 B	C	D	LAF	NA	RD (Max.)	RT	VF	WF	Y	ZB	ZJ
7	3	2 ³ / ₄ -12	2 ¹ / ₄ -12	3 ¹ / ₂	3.749	1	2 ⁵ / ₈	5 ³ / ₄	2 ⁷ / ₈	5 ⁷ / ₁₆	7 ⁷ / ₈	5 ⁵ / ₁₆	2 ¹ / ₄	3 ³ / ₄	12	10 ³ / ₄
	5	4 ³ / ₄ -12	3 ¹ / ₂ -12	5	5.749	1	—	7 ¹ / ₄	4 ⁷ / ₈	7 ⁷ / ₁₆	1 ⁵ / ₁₆	5 ⁵ / ₁₆	2 ¹ / ₄	3 ³ / ₄	12	10 ³ / ₄
	3 ¹ / ₂	3 ¹ / ₄ -12	2 ¹ / ₂ -12	3 ¹ / ₂	4.249	1	3	5 ³ / ₄	3 ³ / ₈	5 ¹⁵ / ₁₆	1 ⁵ / ₁₆	5 ⁵ / ₁₆	2 ¹ / ₄	3 ³ / ₄	12	10 ³ / ₄
	4	3 ³ / ₄ -12	3-12	4	4.749	1	3 ³ / ₈	6 ¹ / ₄	3 ⁷ / ₈	6 ⁵ / ₁₆	1 ⁵ / ₁₆	5 ⁵ / ₁₆	2 ¹ / ₄	3 ³ / ₄	12	10 ³ / ₄
8	3 ¹ / ₂	3 ¹ / ₄ -12	2 ¹ / ₂ -12	3 ¹ / ₂	4.249	1	3	5 ³ / ₄	3 ³ / ₈	5 ¹⁵ / ₁₆	1 ⁵ / ₁₆	5 ⁵ / ₁₆	2 ¹ / ₄	3 ⁷ / ₈	13 ¹ / ₄	11 ³ / ₄
	5 ¹ / ₂	5 ¹ / ₄ -12	4-12	5 ¹ / ₂	6.249	1	—	7 ³ / ₄	5 ³ / ₈	7 ¹⁵ / ₁₆	1 ⁵ / ₁₆	5 ⁵ / ₁₆	2 ¹ / ₄	3 ⁷ / ₈	13 ¹ / ₄	11 ³ / ₄
	4	3 ³ / ₄ -12	3-12	4	4.749	1	3 ³ / ₈	6 ¹ / ₄	3 ⁷ / ₈	6 ⁵ / ₁₆	1 ⁵ / ₁₆	5 ⁵ / ₁₆	2 ¹ / ₄	3 ⁷ / ₈	13 ¹ / ₄	11 ³ / ₄
	5	4 ³ / ₄ -12	3 ¹ / ₂ -12	5	5.749	1	—	7 ¹ / ₄	4 ⁷ / ₈	7 ⁷ / ₁₆	1 ⁵ / ₁₆	5 ⁵ / ₁₆	2 ¹ / ₄	3 ⁷ / ₈	13 ¹ / ₄	11 ³ / ₄

**Table 3 —
Envelope and
Mounting
Dimensions**

B

PL-2

PH-2

PH-3

PHX

SHM

CHE/CHD

**Head Rectangular
Flange Mount
NFFPA Style MF1**

Maximum Pressure Rating - PSI
Push Application

Bore	Rod Dia				
	3	3 1/2	4	5	5 1/2
7	1000	800	400	400	—
8	—	800	700	400	400

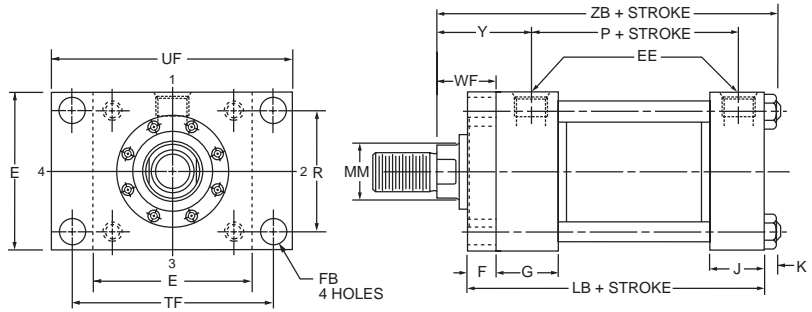
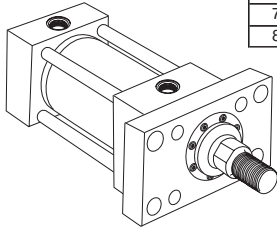

For pressures exceeding those shown use Style MF5 or Style ME5.

**Head Square Flange Mount
NFFPA Style MF5**

Maximum Pressure Rating - PSI
Push Application

Bore	Rod Dia				
	3	3 1/2	4	5	5 1/2
7	2500	2200	1500	1500	—
8	—	2000	2000	1400	1400

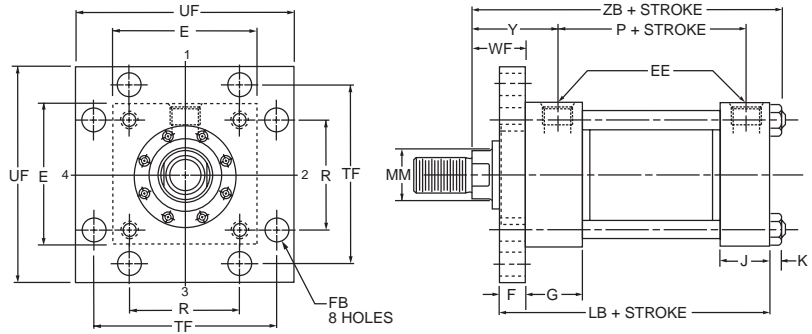
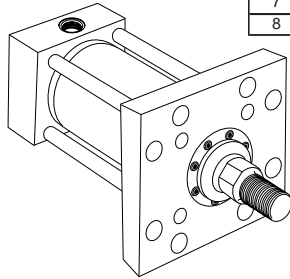

**Head Rectangular Mount
NFFPA Style ME5**

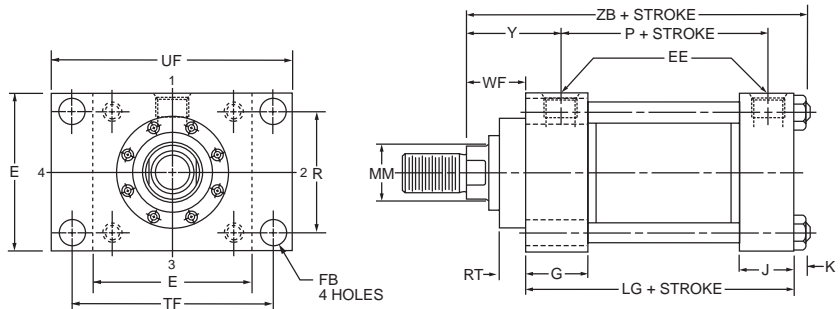
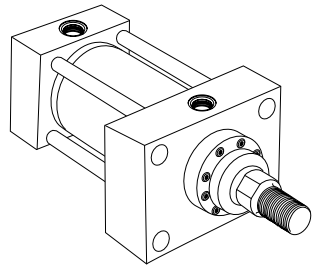

Rod End Dimensions — see Table 2

**Thread Style 2
Small Male**

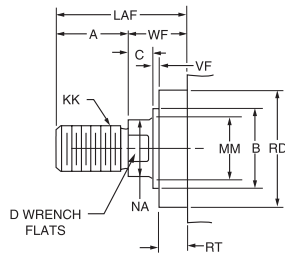

**Thread Style 4
Intermediate Male**

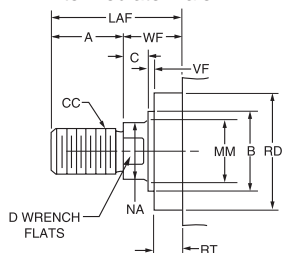

**Thread Style 3
Short Female**

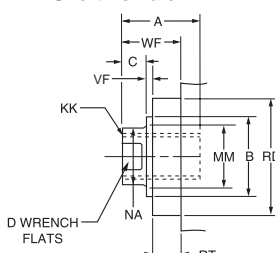

**“Special” Thread
Style 0**

Special thread, extension, rod eye, blank, etc., are also available.

To order, specify “Style 0” and give desired dimensions for KK, A and WF. If otherwise special, furnish dimensioned sketch.

Style 3 stroke restrictions may apply. See Style 3 Minimum Stroke page for details.

Over 2" rod sizes or special rod ends are cut threads. Style 2 rod ends are recommended where the workpiece is secured against the rod shoulder. When the workpiece is not shouldered, style 4 rod ends are recommended over 2" piston rod diameters. Use

style 3 for applications where female rod end threads are required. If rod end is not specified, style 2 will be supplied. On 5" rods and above, (4) .515 dia. spanner wrench holes will be provided instead of wrench flats.

Table 1—Envelope and Mounting Dimensions

Bore	E	EE		F	FB	G	J	K	R	TF	UF	Add Stroke		
		NPTF [Ⓟ]	SAE*									LB	LG	P
7	8½	1¼	20	1	1⅜	2¾	2¾	1¼	6.58	10⅝	12⅝	9½	8½	5½
8	9½	1½	24	1	1⅝	3	3	1½	7.50	11⅓	14	10½	9½	6¼

* SAE straight thread ports are standard and are indicated by port number.

Ⓟ NPTF ports are available at no extra charge.

Table 2—Rod Dimensions

Bore	Rod Dia. MM	Thread		Rod Extensions and Pilot Dimensions										Add Stroke		
		Style 4 CC	Style 2 & 3 KK	A	+0.000 -0.002 B	C	D	LAF	NA	RD (Max.)	RT	VF	WF	Y	ZB	
7	3	2¾-12	2¼-12	3½	3.749	1	2⅝	5¾	2⅞	5⅞	7⅞	7⅞	5⅞	2¼	3¾	12
	5	4¾-12	3½-12	5	5.749	1	–	7¼	4⅞	7⅞	15⅞	5⅞	2¼	3¾	12	
	3½	3¼-12	2½-12	3½	4.249	1	3	5¾	3⅞	5⅞	15⅞	5⅞	2¼	3¾	12	
	4	3¾-12	3-12	4	4.749	1	3⅞	6¼	3⅞	6⅞	15⅞	5⅞	2¼	3¾	12	
8	3½	3¼-12	2½-12	3½	4.249	1	3	5¾	3⅞	5⅞	15⅞	5⅞	2¼	3⅞	13¼	
	5½	5¼-12	4-12	5½	6.249	1	–	7¾	5⅞	7⅞	15⅞	5⅞	2¼	3⅞	13¼	
	4	3¾-12	3-12	4	4.749	1	3⅞	6¼	3⅞	6⅞	15⅞	5⅞	2¼	3⅞	13¼	
	5	4¾-12	3½-12	5	5.749	1	–	7¼	4⅞	7⅞	15⅞	5⅞	2¼	3⅞	13¼	

**Table 3 —
Envelope and
Mounting
Dimensions**

B

PL-2

PH-2

PH-3

PHX

SHM

CHE/CHD

Cap Rectangular
Flange Mount
NFFPA Style MF2

Maximum Pressure Rating - PSI
Pull Application

Bore	Rod Dia				
	3	3 1/2	4	5	5 1/2
7	2000	2000	2500	3000	-
8	-	1700	1700	2200	2500

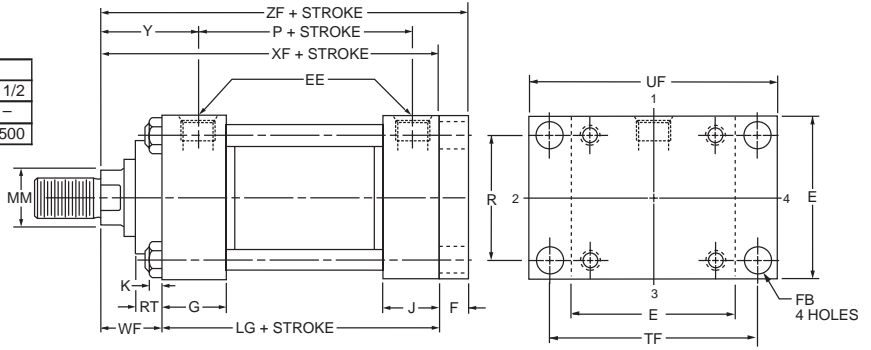
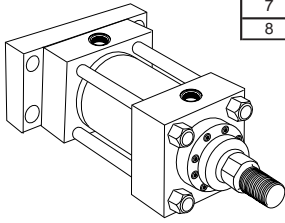

For pressures exceeding those shown use Style MF6 or Style ME6.

Cap Square Flange Mount
NFFPA Style MF6

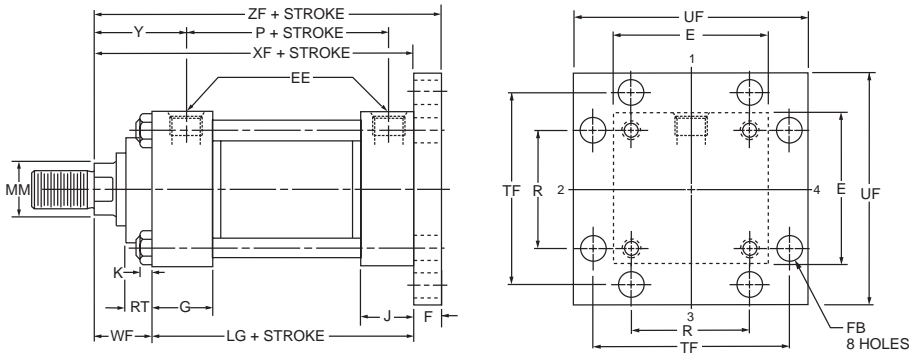
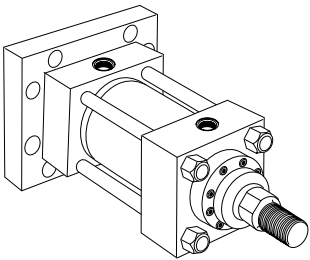

Cap Rectangular Mount
NFFPA Style ME6

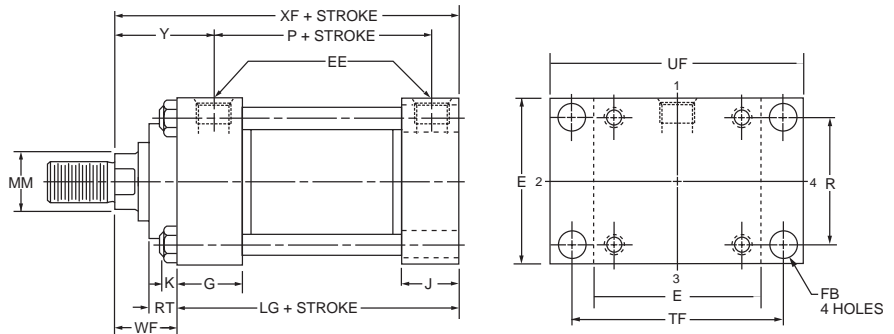
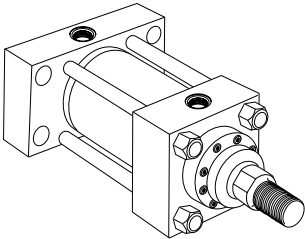

Rod End Dimensions — see Table 2

Thread Style 2
Small Male

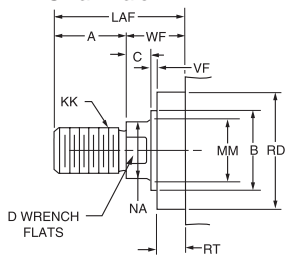

Thread Style 4
Intermediate Male

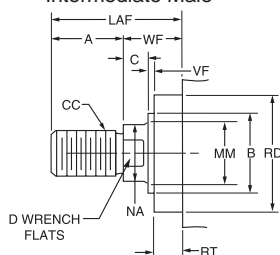

Thread Style 3
Short Female

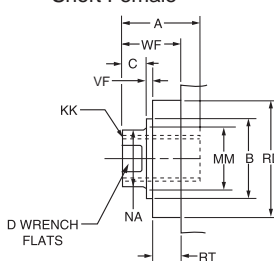

Style 3 stroke restrictions may apply. See Style 3 Minimum Stroke page for details.

“Special” Thread Style 0

Special thread, extension, rod eye, blank, etc., are also available.

To order, specify “Style 0” and give desired dimensions for KK, A and WF. If otherwise special, furnish dimensioned sketch.

Over 2" rod sizes or special rod ends are cut threads. Style 2 rod ends are recommended where the workpiece is secured against the rod shoulder. When the workpiece is not shouldered, style 4 rod ends are recommended over 2" piston rod diameters. Use

style 3 for applications where female rod end threads are required. If rod end is not specified, style 2 will be supplied. On 5" rods and above, (4) .515 dia. spanner wrench holes will be provided instead of wrench flats.

Table 1—Envelope and Mounting Dimensions

Bore	E	EE		F	FB	G	J	K	R	TF	UF	Add Stroke	
		NPTF [⊖]	SAE*									LG	P
7	8½	1¼	20	1	1⅓/16	2¾	2¾	1¼	6.58	10 ⁵ / ₈	12 ⁵ / ₈	8½	5½
8	9½	1½	24	1	1 ⁵ / ₁₆	3	3	1½	7.50	11 ¹³ / ₁₆	14	9½	6¼

* SAE straight thread ports are standard and are indicated by port number.

⊖ NPTF ports are available at no extra charge.

**Table 3 —
Envelope and
Mounting
Dimensions**

Table 2—Rod Dimensions

Bore	Rod Dia. MM	Thread		Rod Extensions and Pilot Dimensions										Add Stroke		
		Style 4 CC	Style 2 & 3 KK	A	+0.000 -0.002 B	C	D	LAF	NA	RD (Max.)	RT	VF	WF	Y	XF	ZF
7	3	2¾-12	2¼-12	3½	3.749	1	2 ⁵ / ₈	5¾	2 ⁷ / ₈	5 ⁷ / ₁₆	7 ⁷ / ₈	5 ⁵ / ₁₆	2¼	3¾	10¾	11¾
	5	4¾-12	3½-12	5	5.749	1	—	7¼	4 ⁷ / ₈	7 ⁷ / ₁₆	15 ¹⁵ / ₁₆	5 ⁵ / ₁₆	2¼	3¾	10¾	11¾
	3½	3¼-12	2½-12	3½	4.249	1	3	5¾	3¾	5 ¹⁵ / ₁₆	15 ¹⁵ / ₁₆	5 ⁵ / ₁₆	2¼	3¾	10¾	11¾
	4	3¾-12	3-12	4	4.749	1	3¾	6¼	3 ⁷ / ₈	6 ⁵ / ₁₆	15 ¹⁵ / ₁₆	5 ⁵ / ₁₆	2¼	3¾	10¾	11¾
8	3½	3¼-12	2½-12	3½	4.249	1	3	5¾	3¾	5 ¹⁵ / ₁₆	15 ¹⁵ / ₁₆	5 ⁵ / ₁₆	2¼	3 ⁷ / ₈	11¾	12¾
	5½	5¼-12	4-12	5½	6.249	1	—	7¾	5¾	7 ¹⁵ / ₁₆	15 ¹⁵ / ₁₆	5 ⁵ / ₁₆	2¼	3 ⁷ / ₈	11¾	12¾
	4	3¾-12	3-12	4	4.749	1	3¾	6¼	3 ⁷ / ₈	6 ⁵ / ₁₆	15 ¹⁵ / ₁₆	5 ⁵ / ₁₆	2¼	3 ⁷ / ₈	11¾	12¾
	5	4¾-12	3½-12	5	5.749	1	—	7¼	4 ⁷ / ₈	7 ⁷ / ₁₆	15 ¹⁵ / ₁₆	5 ⁵ / ₁₆	2¼	3 ⁷ / ₈	11¾	12¾

B

PL-2

PH-2

PH-3

PHX

SHM

CHE/CHD

**Side Lug Mount
NFPA Style MS2**

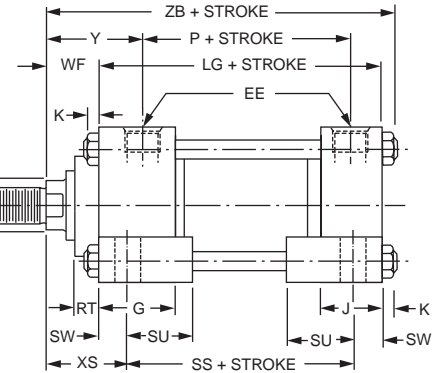
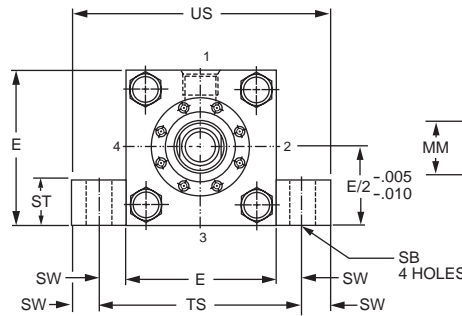
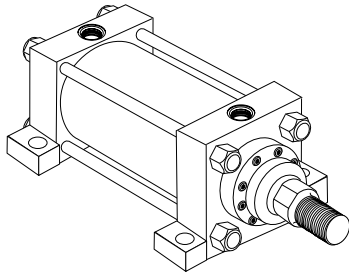

Style MS2 cylinders have mounting lugs welded to the head and cap, and are considered to be a fixed mount that does not absorb force on its centerline. The plane of the mounting surface is not through the centerline of the cylinder, and for this reason Style MS2 cylinders produce a turning moment as the cylinder applies force to the load. This turning moment tends to rotate the

cylinder about its mounting bolts. If the cylinder is not well secured to the machine member on which it is mounted or the load is not well-guided, this turning moment results in side load applied to rod gland and piston bearings. **To avoid this problem, Style MS2 cylinders should be specified with a stroke length at least equal to the bore size.**

**Side Tap Mount
NFPA Style MS4**

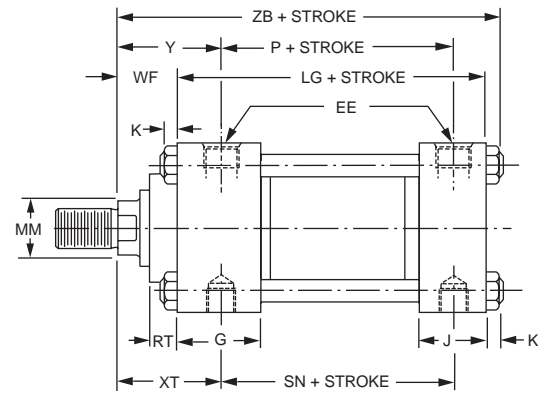
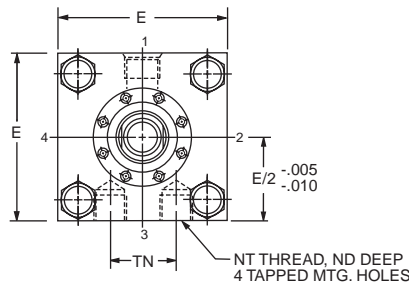
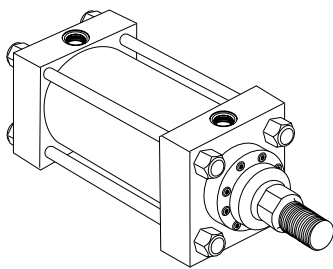

Style MS4 cylinders have side tapped holes for flush mounting, and are considered to be a fixed mount that does not absorb force on its centerline. The plane of the mounting surface is not through the centerline of the cylinder, and for this reason Style MS4 cylinders produce a turning moment as the cylinder applies force to the load. This turning moment tends to rotate the cylinder

about its mounting bolts. If the cylinder is not well secured to the machine member on which it is mounted or the load is not well-guided, this turning moment results in side load applied to rod gland and piston bearings. **To avoid this problem, Style MS4 cylinders should be specified with a stroke length at least equal to the bore size.**

Rod End Dimensions — see Table 2

**Thread Style 2
Small Male**

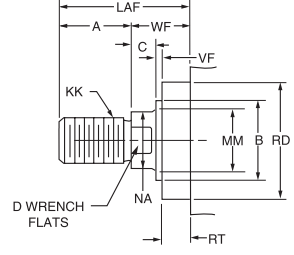

**Thread Style 4
Intermediate Male**

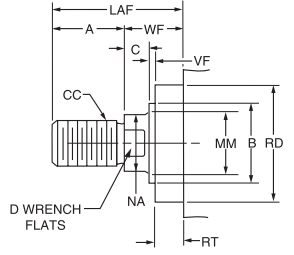

**Thread Style 3
Short Female**

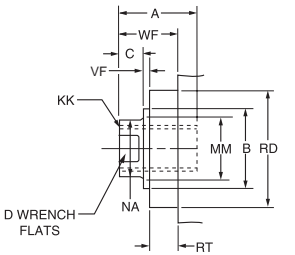

Over 2" rod sizes or special rod ends are cut threads. Style 2 rod ends are recommended where the workpiece is secured against the rod shoulder. When the workpiece is not shouldered, style 4 rod ends are recommended over 2" piston rod diameters. Use

style 3 for applications where female rod end threads are required. If rod end is not specified, style 2 will be supplied. On 5" rods and above, (4) .515 dia. spanner wrench holes will be provided instead of wrench flats.

Style 3 stroke restrictions may apply. See Style 3 Minimum Stroke page for details.

"Special" Thread Style 0

Special thread, extension, rod eye, blank, etc., are also available. To order, specify "Style 0" and give desired dimensions for KK, A and WF. If otherwise special, furnish dimensioned sketch.

Table 1—Envelope and Mounting Dimensions

Bore	E	EE		G	J	K	NT	SB	ST	SU	SW	TN	TS	US	Add Stroke			
		NPTF [⊖]	SAE*												LG	P	SN	SS
7	8 1/2	1 1/4	20	2 3/4	2 3/4	1 1/4	1 1/2-6	1 9/16	1 3/4	2 7/8	1 3/8	3 3/4	11 1/4	14	8 1/2	5 1/2	5 7/8	5 3/4
8	9 1/2	1 1/2	24	3	3	1 1/2	1 1/2-6	1 9/16	1 3/4	2 7/8	1 3/8	4 1/4	12 1/4	15	9 1/2	6 1/4	6 5/8	6 3/4

* SAE straight thread ports are standard and are indicated by port number.

⊖ NPTF ports are available at no extra charge.

**Table 3 —
Envelope and
Mounting
Dimensions**

Table 2—Rod Dimensions

Bore	Rod Dia. MM	Thread		Rod Extensions and Pilot Dimensions										ND	XS	XT	Y	ZB	Add Stroke
		Style 4 CC	Style 2 & 3 KK	A	+0.000 -0.002 B	C	D	LAF	NA	RD (Max.)	RT	VF	WF						
7	3	2 3/4-12	2 1/4-12	3 1/2	3.749	1	2 5/8	5 3/4	2 7/8	5 7/16	7/8	5/16	2 1/4	1 1/8	3 5/8	3 13/16	3 3/4	12	
	5	4 3/4-12	3 1/2-12	5	5.749	1	—	7 1/4	4 7/8	7 7/16	15/16	5/16	2 1/4	1 1/8	3 5/8	3 13/16	3 3/4	12	
	3 1/2	3 1/4-12	2 1/2-12	3 1/2	4.249	1	3	5 3/4	3 3/8	5 15/16	15/16	5/16	2 1/4	1 1/8	3 5/8	3 13/16	3 3/4	12	
	4	3 3/4-12	3-12	4	4.749	1	3 3/8	6 1/4	3 7/8	6 5/16	15/16	5/16	2 1/4	1 1/8	3 5/8	3 13/16	3 3/4	12	
8	3 1/2	3 1/4-12	2 1/2-12	3 1/2	4.249	1	3	5 3/4	3 3/8	5 15/16	15/16	5/16	2 1/4	1 1/2	3 5/8	3 15/16	3 7/8	13 1/4	
	5 1/2	5 1/4-12	4-12	5 1/2	6.249	1	—	7 3/4	5 3/8	7 15/16	15/16	5/16	2 1/4	1 5/16	3 5/8	3 15/16	3 7/8	13 1/4	
	4	3 3/4-12	3-12	4	4.749	1	3 3/8	6 1/4	3 7/8	6 5/16	15/16	5/16	2 1/4	1 1/2	3 5/8	3 15/16	3 7/8	13 1/4	
	5	4 3/4-12	3 1/2-12	5	5.749	1	—	7 1/4	4 7/8	7 7/16	15/16	5/16	2 1/4	1 1/2	3 5/8	3 15/16	3 7/8	13 1/4	

B

PL-2

PH-2

PH-3

PHX

SHM

CHE/CHD

Cap Fixed Clevis Mount
NFA Style MP1

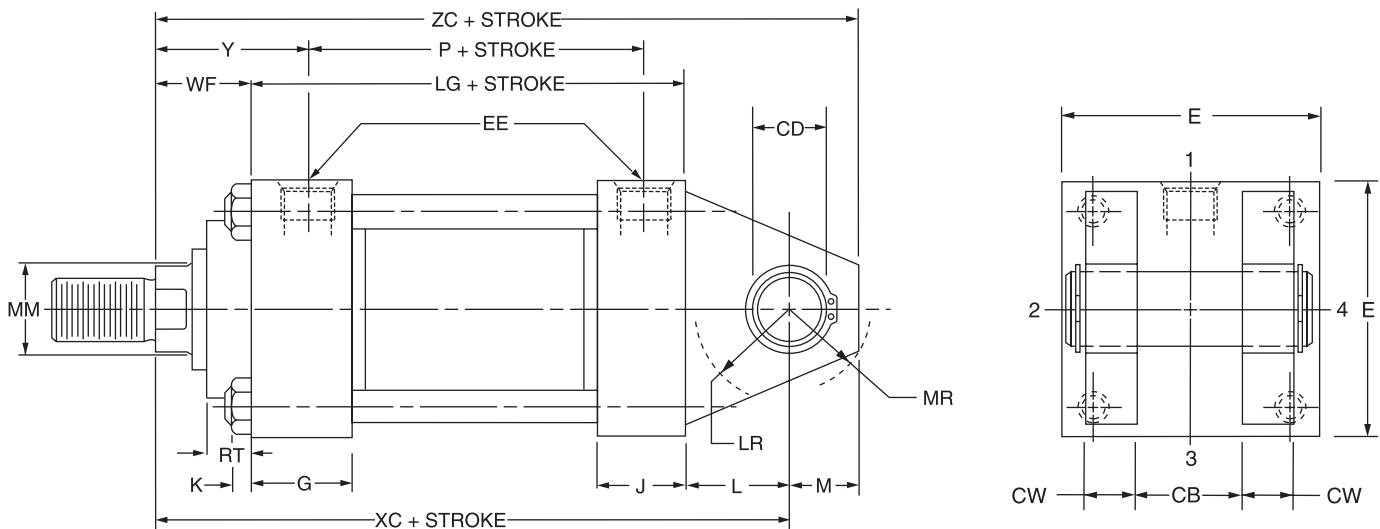
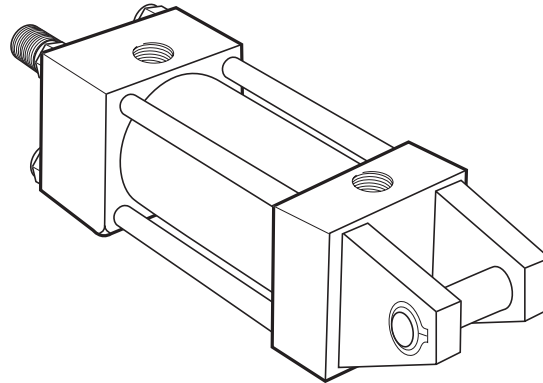

Rod End Dimensions — see Table 2

Thread Style 2
Small Male

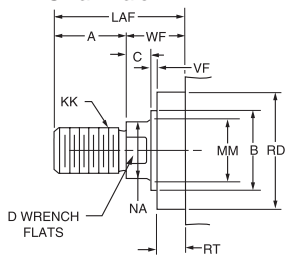

Thread Style 4
Intermediate Male

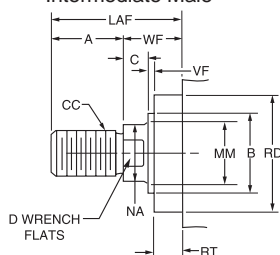

Thread Style 3
Short Female

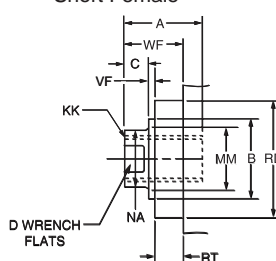

Style 3 stroke restrictions may apply. See Style 3 Minimum Stroke page for details.

“Special” Thread Style 0

Special thread, extension, rod eye, blank, etc., are also available.

To order, specify “Style 0” and give desired dimensions for KK, A and WF. If otherwise special, furnish dimensioned sketch.

Over 2" rod sizes or special rod ends are cut threads. Style 2 rod ends are recommended where the workpiece is secured against the rod shoulder. When the workpiece is not shouldered, style 4 rod ends are recommended over 2" piston rod diameters. Use

style 3 for applications where female rod end threads are required. If rod end is not specified, style 2 will be supplied. On 5" rods and above, (4) .515 dia. spanner wrench holes will be provided instead of wrench flats.

Table 1—Envelope and Mounting Dimensions

Bore	CB	+.000 -.002 CD†	CW	E	EE		G	J	K	L	LR	M	MR	R	Add Stroke	
					NPTF⊖	SAE*									LG	P
7	3	2.501	1½	8½	1¼	20	2¾	2¾	1¼	3	2¾	2½	2⅞	6.58	8½	5½
8	3	3.001	1½	9½	1½	24	3	3	1½	3¼	3¼	2¾	3⅞	7.50	9½	6¼

* SAE straight thread ports are standard and are indicated by port number.

⊖ NPTF ports are available at no extra charge.

† Dimension CD is pin diameter.

**Table 3 —
Envelope and
Mounting
Dimensions**

Table 2—Rod Dimensions

Bore	Rod Dia. MM	Thread		Rod Extensions and Pilot Dimensions										Add Stroke		
		Style 4 CC	Style 2 & 3 KK	A	+.000 -.002 B	C	D	LAF	NA	RD (Max.)	RT	VF	WF	Y	XC	ZC
7	3	2¾-12	2¼-12	3½	3.749	1	2⅝	5¾	2⅞	5⅞	7/8	5/16	2¼	3¾	13¾	16¼
	5	4¾-12	3½-12	5	5.749	1	—	7¼	4⅞	7⅞	15/16	5/16	2¼	3¾	13¾	16¼
	3½	3¼-12	2½-12	3½	4.249	1	3	5¾	3¾	5½	15/16	5/16	2¼	3¾	13¾	16¼
	4	3¾-12	3-12	4	4.749	1	3⅝	6¼	3⅞	6½	15/16	5/16	2¼	3¾	13¾	16¼
8	3½	3¼-12	2½-12	3½	4.249	1	3	5¾	3¾	5½	15/16	5/16	2¼	3⅞	15	17¾
	5½	5¼-12	4-12	5½	6.249	1	—	7¾	5¾	7½	15/16	5/16	2¼	3⅞	15	17¾
	4	3¾-12	3-12	4	4.749	1	3⅝	6¼	3⅞	6½	15/16	5/16	2¼	3⅞	15	17¾
	5	4¾-12	3½-12	5	5.749	1	—	7¼	4⅞	7⅞	15/16	5/16	2¼	3⅞	15	17¾

B

PL-2

PH-2

PH-3

PHX

SHM

CHE/CHD

**Head Trunnion Mount
NFFA Style MT1**

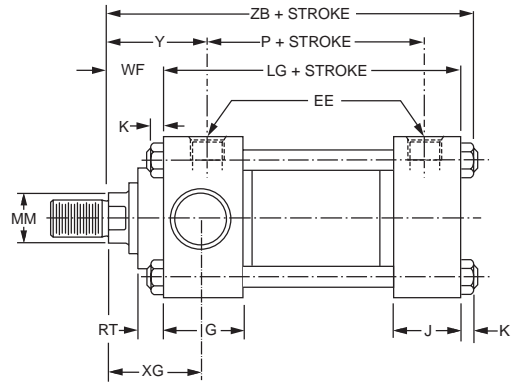
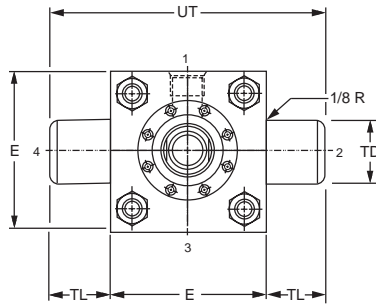
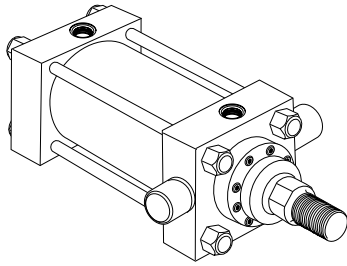

**Cap Trunnion Mount
NFFA Style MT2**

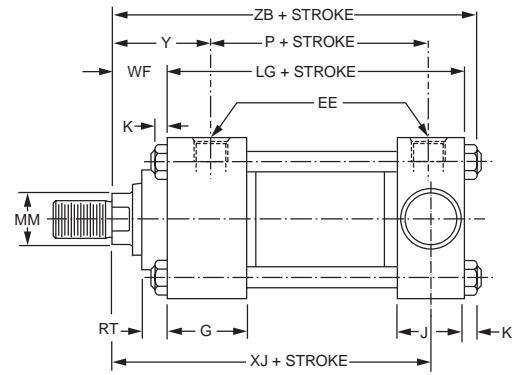
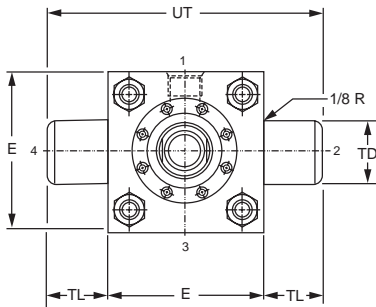
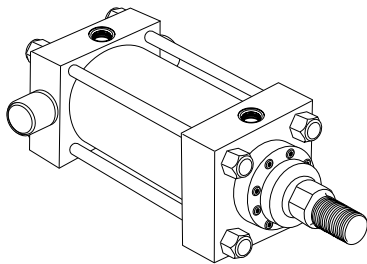

**Intermediate Trunnion Mount
NFFA Style MT4**

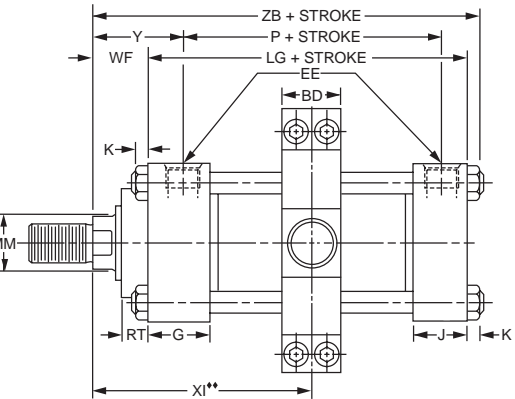
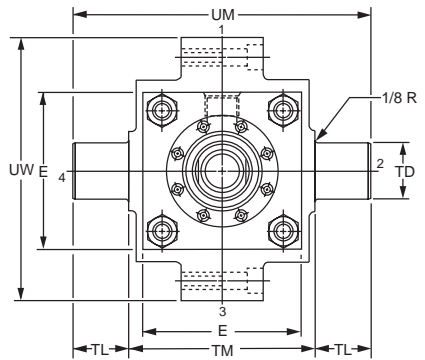
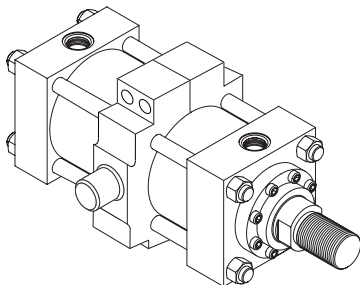

◆◆ Dimension XI to be specified by customer.

Rod End Dimensions — see Table 2

**Thread Style 2
Small Male**

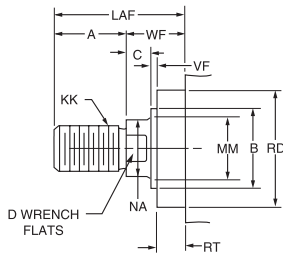

**Thread Style 4
Intermediate Male**

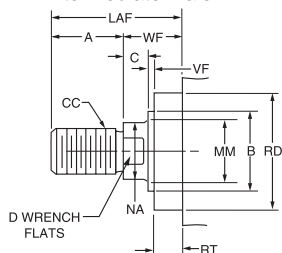

**Thread Style 3
Short Female**

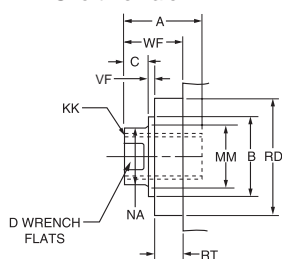

**"Special" Thread
Style 0**

Special thread, extension, rod eye, blank, etc., are also available.

To order, specify "Style 0" and give desired dimensions for KK, A and WF. If otherwise special, furnish dimensioned sketch.

Style 3 stroke restrictions may apply. See Style 3 Minimum Stroke page for details.

Over 2" rod sizes or special rod ends are cut threads. Style 2 rod ends are recommended where the workpiece is secured against the rod shoulder. When the workpiece is not shouldered, style 4 rod ends are recommended over 2" piston rod diameters. Use

style 3 for applications where female rod end threads are required. If rod end is not specified, style 2 will be supplied. On 5" rods and above, (4) .515 dia. spanner wrench holes will be provided instead of wrench flats.

Table 1—Envelope and Mounting Dimensions

Bore	BD	E	EE		G	J	K	+.000 -.002 TD	TL	TM	UM	UT	UW	Add Stroke	
			NPTF [⊖]	SAE*										LG	P
7	3	8½	1¼	20	2¾	2¾	1¼	2.500	2½	9¾	14¾	13½	11½	8½	5½
8	3½	9½	1½	24	3	3	1½	3.000	3	11	17	15½	13¾	9½	6¼

* SAE straight thread ports are standard and are indicated by port number.

⊖ NPTF ports are available at no extra charge.

Table 3 —
Envelope and
Mounting Dimensions

Table 2—Rod Dimensions

Bore	Rod Dia. MM	Thread		Rod Extensions and Pilot Dimensions										Add Stroke				
		Style 4 CC	Style 2 & 3 KK	A	+.000 -.002 B	C	D	LAF	NA	RD (Max.)	RT	VF	WF	XG	Min. XI**	Y	XJ	ZB
7	3	2¾-12	2¼-12	3½	3.749	1	2 ⁵ / ₈	5¾	2 ⁷ / ₈	5 ⁷ / ₁₆	7 ⁸ / ₈	5 ⁵ / ₁₆	2¼	3 ⁵ / ₈	6 ⁹ / ₁₆	3¾	9 ³ / ₈	12
	5	4¾-12	3½-12	5	5.749	1	—	7¼	4 ⁷ / ₈	7 ⁷ / ₁₆	1 ¹⁵ / ₁₆	5 ⁵ / ₁₆	2¼	3 ⁵ / ₈	6 ⁹ / ₁₆	3¾	9 ³ / ₈	12
	3½	3¼-12	2½-12	3½	4.249	1	3	5¾	3¾	5 ¹⁵ / ₁₆	1 ¹⁵ / ₁₆	5 ⁵ / ₁₆	2¼	3 ⁵ / ₈	6 ⁹ / ₁₆	3¾	9 ³ / ₈	12
	4	3¾-12	3-12	4	4.749	1	3 ³ / ₈	6¼	3 ⁷ / ₈	6 ⁵ / ₁₆	1 ¹⁵ / ₁₆	5 ⁵ / ₁₆	2¼	3 ⁵ / ₈	6 ⁹ / ₁₆	3¾	9 ³ / ₈	12
8	3½	3¼-12	2½-12	3½	4.249	1	3	5¾	3¾	5 ¹⁵ / ₁₆	1 ¹⁵ / ₁₆	5 ⁵ / ₁₆	2¼	3¾	7 ¹ / ₁₆	3 ⁷ / ₈	10¼	13¼
	5½	5¼-12	4-12	5½	6.249	1	—	7¾	5¾	7 ¹⁵ / ₁₆	1 ¹⁵ / ₁₆	5 ⁵ / ₁₆	2¼	3¾	7 ¹ / ₁₆	3 ⁷ / ₈	10¼	13¼
	4	3¾-12	3-12	4	4.749	1	3 ³ / ₈	6¼	3 ⁷ / ₈	6 ⁵ / ₁₆	1 ¹⁵ / ₁₆	5 ⁵ / ₁₆	2¼	3¾	7 ¹ / ₁₆	3 ⁷ / ₈	10¼	13¼
	5	4¾-12	3½-12	5	5.749	1	—	7¼	4 ⁷ / ₈	7 ⁷ / ₁₆	1 ¹⁵ / ₁₆	5 ⁵ / ₁₆	2¼	3¾	7 ¹ / ₁₆	3 ⁷ / ₈	10¼	13¼

**Dimension XI to be specified by customer.

B

PL-2

PH-2

PH-3

PHX

SHM

CHE/CHD

How to Use Double Rod Cylinder Dimension Drawings

To determine dimensions for a double rod cylinder, first refer to the desired single rod mounting style cylinder shown on preceding pages of this catalog. After selecting necessary dimensions from that drawing return to this page, supplement the single rod dimensions with those shown on drawing and dimension table below. Note that double rod cylinders have a head (Dim. G) at both ends and that dimension LD replaces LG. The double rod dimensions differ from, or are in addition to, those for single rod cylinders shown on preceding pages and provide the information needed to completely dimension a double rod cylinder.

On a double rod cylinder where the two rod ends are different, be sure to clearly state which rod end is to be assembled at which end. Port position 1 is standard. If other than standard, specify pos. 2, 3 or 4 when viewed from one end only.

All dimensions are in inches and apply to smallest rod sizes only. For alternate rod sizes, determine all envelope dimensions (within LD dim.) as described above and then use appropriate rod end dimensions for proper rod size from single rod cylinder.

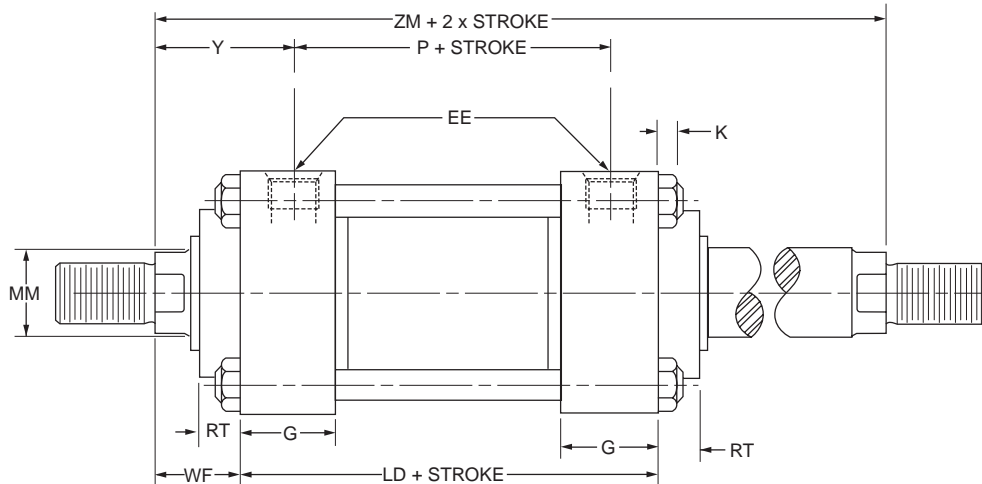

Bore	Rod Dia. MM	Add Stroke			Add 2X Stroke
		LD	Model MDS4 SN	Model MDS2 SS	ZM
7	3	8½	5¾	5¾	13
8	3½	9½	6⅛	6¾	14

Linear Alignment Couplers are available in 12 standard thread sizes...

Cost Saving Features and Benefits Include:

- Maximum reliability for trouble-free operation, long life and lower operating costs
- Increased cylinder life by reducing wear on piston and rod bearings
- Simplified cylinder installation and reduced assembly costs
- Increased rod bearing and rod seal life for lower maintenance costs

Alignment Coupler

See Table 1 for Part Numbers and Dimensions

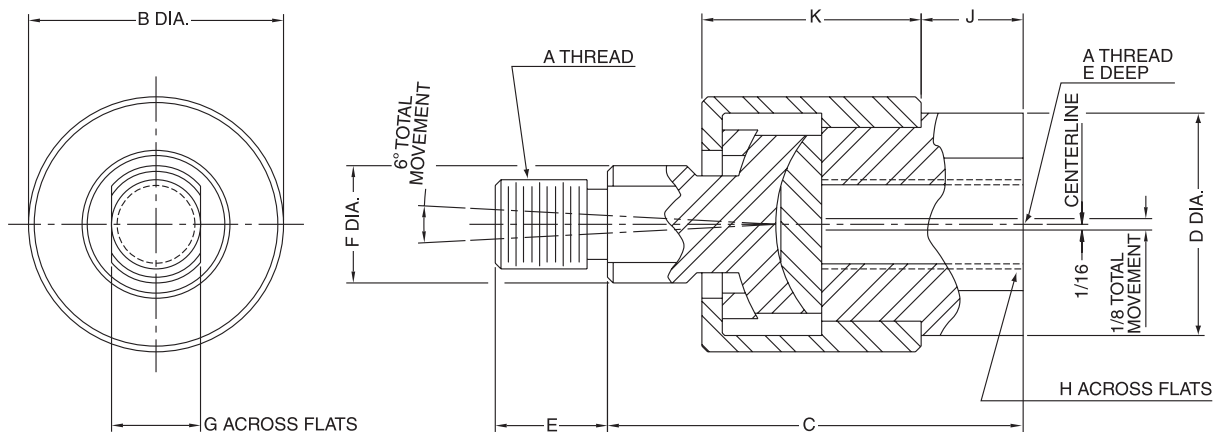

Table 1 — Part Numbers and Dimensions

Part No.	A	B	C	D	E	F	G	H	J	K	Max. Pull Load (lbs.)	Approx. Weight (lbs.)
1347570031	5/16-24	1 1/8	1 3/4	15/16	1/2	1/2	3/8	3/4	3/8	15/16	1200	.35
1347570038	3/8-24	1 1/8	1 3/4	15/16	1/2	1/2	3/8	3/4	3/8	15/16	2425	.35
1347570044	7/16-20	1 3/8	2	1 1/8	3/4	5/8	1/2	7/8	3/8	1 3/32	3250	.55
1347570050	1/2-20	1 3/8	2	1 1/8	3/4	5/8	1/2	7/8	3/8	1 3/32	4450	.55
1347570063	5/8-18	1 3/8	2	1 1/8	3/4	5/8	1/2	7/8	3/8	1 3/32	6800	.55
1347570075	3/4-16	2	2 5/16	1 5/8	1 1/8	15/16	3/4	1 5/16	7/16	1 9/32	9050	1.4
1347570088	7/8-14	2	2 5/16	1 5/8	1 1/8	15/16	3/4	1 5/16	7/16	1 9/32	14450	1.4
1347570100	1-14	3 1/8	3	2 3/8	1 5/8	1 7/16	1 1/4	1 7/8	3/4	1 25/32	19425	4.8
1347570125	1 1/4-12	3 1/8	3	2 3/8	1 5/8	1 7/16	1 1/4	1 7/8	3/4	1 25/32	30500	4.8
1337390125	1 1/4-12	3 1/2	4	2	2	1 1/2	1 1/4	1 11/16	3/4	2 1/2	30500	6.9
1337390150	1 1/2-12	4	4 3/8	2 1/4	2 1/4	1 3/4	1 1/2	1 15/16	7/8	2 3/4	45750	9.8
1337390175	1 3/4-12	4	4 3/8	2 1/4	2 1/4	1 3/4	1 1/2	1 15/16	7/8	2 3/4	58350	9.8
1337390188	1 7/8-12	5	5 5/8	3	3	2 1/4	1 15/16	2 5/8	1 3/8	3 3/8	67550	19.8

How to Order Linear Alignment Couplers — When ordering a cylinder with a threaded male rod end, specify the coupler of equal thread size by part number as listed in Table 1, i.e.; Piston Rod “KK” dimension is 3/4” - 16”, specify coupler part number 1347570075.

Cylinder Accessories

Schrader Bellows offers a complete range of cylinder accessories to assure you of the greatest versatility in present and future cylinder applications.

Rod End Accessories

Accessories offered for the rod end of the cylinder include Rod Clevis, Eye Bracket, Knuckle, Clevis Bracket, and Pivot Pin. To select the proper part number for any desired accessory, refer to the table below or on the opposite page and look in the row to the right of the rod thread in the first column. For economical accessory selection, it is recommended that rod end style 2 be specified on your cylinder order.

Accessory Load Capacity

The various accessories have been load rated for your convenience. The Load Capacity in lbs. is the recommended maximum load for that accessory based on a 4:1 design factor in tension. (Pivot Pin is rated in shear.) Before specifying, compare the actual load or the tension (pull) force at maximum operating pressure of the cylinder with the load capacity of the accessory you plan to use. If load or pull force of cylinder exceeds load capacity of accessory, consult factory.

Thread Size	Rod Clevis		Mounting Plate or Eye Bracket		Pivot Pin	
	Part Number	Load Capacity (Lbs.)	Part Number	Load Capacity (Lbs.)	Part Number	Shear Capacity (Lbs.)
5/16-24	0512210000†	2600	0740770000	1700	—	—
7/16-20	0509400000	4250	0691950000	4100	0683680000	8600
1/2-20	0509410000	4900	0691950000	4100	0683680000	8600
3/4-16	0509420000	11200	0691960000	10500	0683690000	19300
3/4-16	1332840000	11200	0691960000	10500	0683690000	19300
7/8-14	0509430000	18800	*0853610000	20400	0683700000	34300
1-14	0509440000	19500	*0853610000	20400	0683700000	34300
1-14	1332850000	19500	*0853610000	20400	0683700000	34300
1 1/4-12	0509450000	33500	0691980000	21200	0683710000	65000
1 1/4-12	1332860000	33500	0691980000	21200	0683710000	65000
1 1/2-12	0509460000	45600	*0853620000	49480	0683720000	105200
1 3/4-12	0509470000	65600	*0853630000	70000	0683730000	137400
1 7/8-12	0509480000	65600	*0853630000	70000	0683730000	137400
2 1/4-12	0509490000	98200	*0853640000	94200	0683740000	214700
2 1/2-12	0509500000	98200	*0853650000	121900	0683750000	309200
2 3/4-12	0509510000	98200	*0853650000	121900	0683750000	309200
3 1/4-12	0509520000	156700	0735380000	57400	0735450000	420900
3 1/2-12	0509530000	193200	0735390000	75000	0735470000	565800
4-12	0509540000	221200	0735390000	75000	0735470000	565800

† Includes pivot pin.

* Cylinder accessory dimensions conform to NFPA recommended standard NFPA/T3.6.8 R1-1984, NFPA recommended standard fluid power systems – cylinder – dimensions for accessories for cataloged square head industrial cylinders.

Rod Clevis Dimensions

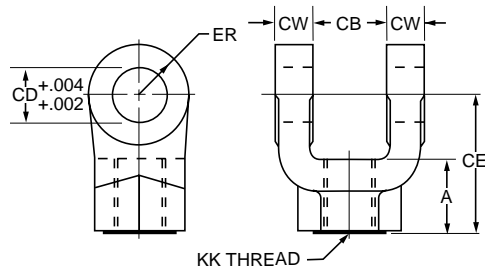

Pivot Pin Dimensions

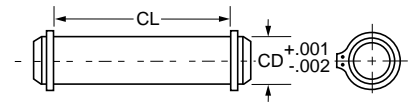

Part Number	A	CB	CD	CE	CW	ER	KK
0512210000†	13/16	11/32	5/16	2 1/4	13/64	19/64	5/16-24
0509400000	3/4	3/4	1/2	1 1/2	1/2	1/2	7/16-20
0509410000	3/4	3/4	1/2	1 1/2	1/2	1/2	1/2-20
0509420000	1 1/8	1 1/4	3/4	2 1/8	5/8	3/4	3/4-16
1332840000	1 1/8	1 1/4	3/4	2 3/8	5/8	3/4	3/4-16
0509430000	1 5/8	1 1/2	1	2 15/16	3/4	1	7/8-14
0509440000	1 5/8	1 1/2	1	2 15/16	3/4	1	1-14
1332850000	1 5/8	1 1/2	1	3 1/8	3/4	1	1-14
0509450000	1 7/8	2	1 3/8	3 3/4	1	1 3/8	1 1/4-12
1332860000	2	2	1 3/8	4 1/8	1	1 3/8	1 1/4-12
0509460000	2 1/4	2 1/2	1 3/4	4 1/2	1 1/4	1 3/4	1 1/2-12
0509470000	3	2 1/2	2	5 1/2	1 1/4	2	1 3/4-12
0509480000	3	2 1/2	2	5 1/2	1 1/4	2	1 7/8-12
0509490000	3 1/2	3	2 1/2	6 1/2	1 1/2	2 1/2	2 1/4-12
0509500000	3 1/2	3	3	6 3/4	1 1/2	2 3/4	2 1/2-12
0509510000	3 1/2	3	3	6 3/4	1 1/2	2 3/4	2 3/4-12
0509520000	3 1/2‡	4	3 1/2	7 3/4	2	3 1/2	3 1/4-12
0509530000	4‡	4 1/2	4	8 13/16	2 1/4	4	3 1/2-12
0509540000	4‡	4 1/2	4	8 13/16	2 1/4	4	4-12

Part Number	CD	CL
0683680000	1/2	1 7/8
0683690000	3/4	2 5/8
0683700000	1	3 1/8
0683710000	1 3/8	4 1/8
0683720000	1 3/4	5 3/16
0683730000	2	5 3/16
0683740000	2 1/2	6 3/16
0683750000	3	6 1/4
0735450000	3 1/2	8 1/4
0735470000	4	9

1. Pivot Pins are furnished with Clevis Mounted Cylinders as standard.
2. Pivot Pins are furnished with (2) Retainer Rings.
3. Pivot Pins must be ordered as a separate item if to be used with Knuckles, Rod Clevises, or Clevis Brackets.

† Includes Pivot Pin

‡ Consult appropriate cylinder rod end dimensions for compatibility.

Mounting Plate or Eye Bracket Dimensions

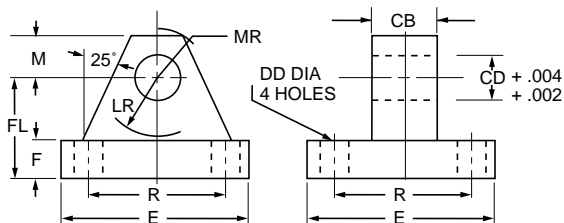

1. When used to mate with the Rod Clevis, select by thread size in table on opposite page.
2. When used to mount the Style PB1 Cylinders, select by bore size below.

Part Number	CB	CD	DD	E	F	FL	LR	M	MR	R	Bore
0740770000	5/16	5/16	17/64	2 1/4	3/8	1	5/8	3/8	1/2	1.75	—
0691950000	3/4	1/2	13/32	2 1/2	3/8	1 1/8	3/4	1/2	9/16	1.63	—
0691960000	1 1/4	3/4	17/32	3 1/2	5/8	1 7/8	1 1/4	3/4	7/8	2.55	—
*0853610000	1 1/2	1	21/32	4 1/2	7/8	2 3/8	1 1/2	1	1 1/4	3.25	—
0691980000	2	1 3/8	21/32	5	7/8	3	2 1/8	1 3/8	1 5/8	3.82	—
*0853620000	2 1/2	1 3/4	29/32	6 1/2	1 1/8	3 3/8	2 1/4	1 3/4	2 1/8	4.95	—
*0853630000	2 1/2	2	1 1/16	7 1/2	1 1/2	4	2 1/2	2	2 7/16	5.73	—
*0853640000	3	2 1/2	1 3/16	8 1/2	1 3/4	4 3/4	3	2 1/2	3	6.58	7"
*0853650000	3	3	1 5/16	9 1/2	2	5 1/4	3 1/4	2 3/4	3 1/4	7.50	8"
0735380000	4	3 1/2	1 13/16	12 5/8	1 11/16	5 11/16	4	3 1/2	4 1/8	9.62	—
0735390000	4 1/2	4	2 1/16	14 7/8	1 15/16	6 7/16	4 1/2	4	5 1/4	11.45	—

* Cylinder accessory dimensions conform to NFPA recommended standard NFPA/T3.6.8 R1-1984, NFPA recommended standard fluid power systems - cylinder - dimensions for accessories for cataloged square head industrial cylinders.

Rod End Accessories

Accessories offered for the rod end of the cylinder include Rod Clevis, Eye Bracket, Knuckle, Clevis Bracket, and Pivot Pin. To select the proper part number for any desired accessory, refer to the table below or on the opposite page and look in the row to the right of the rod thread in the first column. For economical accessory selection, it is recommended that rod end style 2 be specified on your cylinder order.

Accessory Load Capacity

The various accessories have been load rated for your convenience. The Load Capacity in lbs. is the recommended maximum load for that accessory based on a 4:1 design factor in tension. (Pivot Pin is rated in shear.) Before specifying, compare the actual load or the tension (pull) force at the maximum operating pressure of the cylinder with the load capacity of the accessory you plan to use. If load or pull force of cylinder exceeds load capacity of accessory, consult factory.

Thread Size	Knuckle		Clevis Bracket		Pivot Pin	
	Part Number	Load Capacity (Lbs.)	Part Number	Load Capacity (Lbs.)	Part Number	Shear Capacity (Lbs.)
5/16-24	0740750000	3300	0740760000	3600	0740780000	6600
7/16-20	0690890000	5000	0692050000	7300	0683680000	8600
1/2-20	0690900000	5700	0692050000	7300	0683680000	8600
3/4-16	0690910000	12100	0692060000	14000	0683690000	19300
7/8-14	0690920000	13000	0692070000	19200	0683700000	34300
1-14	0690930000	21700	0692070000	19200	0683700000	34300
1 1/4-12	0690940000	33500	0692080000	36900	0683710000	65000
1 1/2-12	0690950000	45000	0692090000	34000	0683720000	105200
1 3/4-12	0690960000	53500	0692100000	33000	0692150000	137400
1 7/8-12	0690970000	75000	0692100000	33000	0692150000	137400
2 1/4-12	0690980000	98700	0692110000	34900	0683740000	214700
2 1/2-12	0690990000	110000	0692120000	33800	0683750000	309200
2 3/4-12	0691000000	123300	0692130000	36900	0692160000	309200
3 1/4-12	0735360000	161300	0735420000	83500	0735450000	420900
3 1/2-12	0734370000	217300	0735420000	83500	0735450000	420900
4-12	0734380000	273800	0735430000	102600	0821810000	565800
4 1/2-12	0734390000	308500	0735440000	108400	0735470000•	565800

• This size supplied with cotter pins.

Knuckle Dimensions

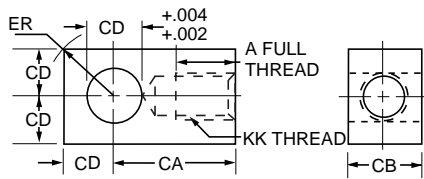

Pivot Pin Dimensions

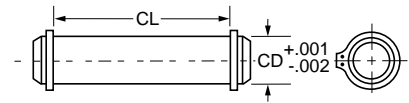

Part Number	A	CA	CB	CD	ER	KK
0740750000	3/4	1 1/2	7/16	7/16	19/32	5/16-24
0690890000	3/4	1 1/2	3/4	1/2	23/32	7/16-20
0690900000	3/4	1 1/2	3/4	1/2	23/32	1/2-20
0690910000	1 1/8	2 1/16	1 1/4	3/4	1 1/16	3/4-16
0690920000	1 1/8	2 3/8	1 1/2	1	1 7/16	7/8-14
0690930000	1 5/8	2 13/16	1 1/2	1	1 7/16	1-14
0690940000	2	3 7/16	2	1 3/8	1 31/32	1 1/4-12
0690950000	2 1/4	4	2 1/2	1 3/4	2 1/2	1 1/2-12
0690960000	2 1/4	4 3/8	2 1/2	2	2 27/32	1 3/4-12
0690970000	3	5	2 1/2	2	2 27/32	1 7/8-12
0690980000	3 1/2	5 13/16	3	2 1/2	3 9/16	2 1/4-12
0690990000	3 1/2	6 1/8	3	3	4 1/4	2 1/2-12
0691000000	3 5/8	6 1/2	3 1/2	3	4 1/4	2 3/4-12
0735360000	4 1/2	7 5/8	4	3 1/2	4 31/32	3 1/4-12
0734370000	5	7 5/8	4	3 1/2	4 31/32	3 1/2-12
0734380000	5 1/2	9 1/8	4 1/2	4	5 11/16	4-12
0734390000	5 1/2	9 1/8	5	4	5 11/16	4 1/2-12

Part Number	CD	CL
0740780000	7/16	1 5/16
0683680000	1/2	1 7/8
0683690000	3/4	2 5/8
0683700000	1	3 1/8
0683710000	1 3/8	4 1/8
0683720000	1 3/4	5 3/16
0692150000	2	5 11/16
0683740000	2 1/2	6 3/16
0683750000	3	6 1/4
0692160000	3	6 3/4
0735450000	3 1/2	8 1/4
0821810000	4	8 5/8
0735470000*	4	9

- * This size supplied with cotter pins.
- 1. Pivot Pins are furnished with Clevis Mounted Cylinders as standard.
- 2. Pivot Pins are furnished with (2) Retainer Rings.
- 3. Pivot Pins must be ordered as a separate item if to be used with Knuckles, Rod Clevises, or Clevis Brackets.

Clevis Bracket Dimensions

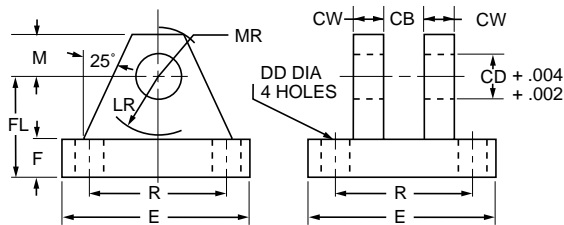

Part Number	CB	CD	CW	DD	E	F	FL	LR	M	MR	R
0740760000	15/32	7/16	3/8	17/64	2 1/4	3/8	1	5/8	3/8	1/2	1.75
0692050000	3/4	1/2	1/2	13/32	3 1/2	1/2	1 1/2	3/4	1/2	5/8	2.55
0692060000	1 1/4	3/4	5/8	17/32	5	5/8	1 7/8	1 3/16	3/4	29/32	3.82
0692070000	1 1/2	1	3/4	21/32	6 1/2	3/4	2 1/4	1 1/2	1	1 1/4	4.95
0692080000	2	1 3/8	1	21/32	7 1/2	7/8	3	2	1 3/8	1 21/32	5.73
0692090000	2 1/2	1 3/4	1 1/4	29/32	9 1/2	7/8	3 5/8	2 3/4	1 3/4	2 7/32	7.50
0692100000	2 1/2	2	1 1/2	1 1/16	12 3/4	1	4 1/4	3 3/16	2 1/4	2 25/32	9.40
0692110000	3	2 1/2	1 1/2	1 3/16	12 3/4	1	4 1/2	3 1/2	2 1/2	3 1/8	9.40
0692120000	3	3	1 1/2	1 5/16	12 3/4	1	6	4 1/4	3	3 19/32	9.40
0692130000	3 1/2	3	1 1/2	1 5/16	12 3/4	1	6	4 1/4	3	3 19/32	9.40
0735420000	4	3 1/2	2	1 13/16	15 1/2	1 11/16	6 11/16	5	3 1/2	4 1/8	12.00
0735430000	4 1/2	4	2	2 1/16	17 1/2	1 15/16	7 11/16	5 3/4	4	4 7/8	13.75
0735440000	5	4	2	2 1/16	17 1/2	1 15/16	7 11/16	5 3/4	4	4 7/8	13.75

Cylinder accessory dimensions conform to NFPA recommended standard NFPT/T3.6.8 R1-1984, NFPA recommended standard fluid power systems - cylinder - dimensions for accessories for cataloged square head industrial cylinders.

Schrader Bellows “Style 6” Piston Rod End

Rod end flange coupling for Schrader Bellows PH-3 Series Hydraulic Cylinders

- Simplifies alignment
- Reduces assembly time
- Allows full rated hydraulic pressure in push and pull directions

Style 6 Rod End

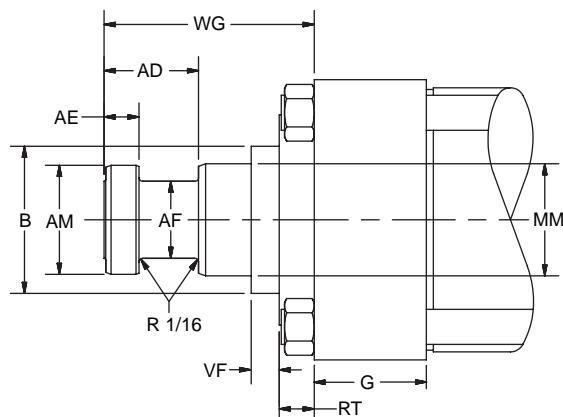

Dimensions Style 6 Rod End

MM Rod Dia.	AD	AE	AF	AM	WG
3	2 ⁷ / ₁₆	7/8	2 ¹ / ₄	2.95	4 ⁷ / ₈
3 ¹ / ₂	2 ¹¹ / ₁₆	1	2 ¹ / ₂	3.45	5 ⁵ / ₈
4	2 ¹¹ / ₁₆	1	3	3.95	5 ³ / ₄
4 ¹ / ₂	3 ³ / ₁₆	1 ¹ / ₂	3 ¹ / ₂	4.45	6 ¹ / ₂
5	3 ³ / ₁₆	1 ¹ / ₂	3 ⁷ / ₈	4.95	6 ⁵ / ₈
5 ¹ / ₂	3 ¹⁵ / ₁₆	1 ⁷ / ₈	4 ³ / ₈	5.45	7 ¹ / ₂

See Cylinder Catalog for B, G, RT and VF per bore and rod diameter.

Consult Factory for availability of mounting accessories and Hardware.

How To Order

Complete Model Number and place a “6” in the Piston Rod End designator position.

Example: PHJA73561x12.00

Schrader Bellows “Style 6” Piston Rod End Split Couplers and Weld Plates

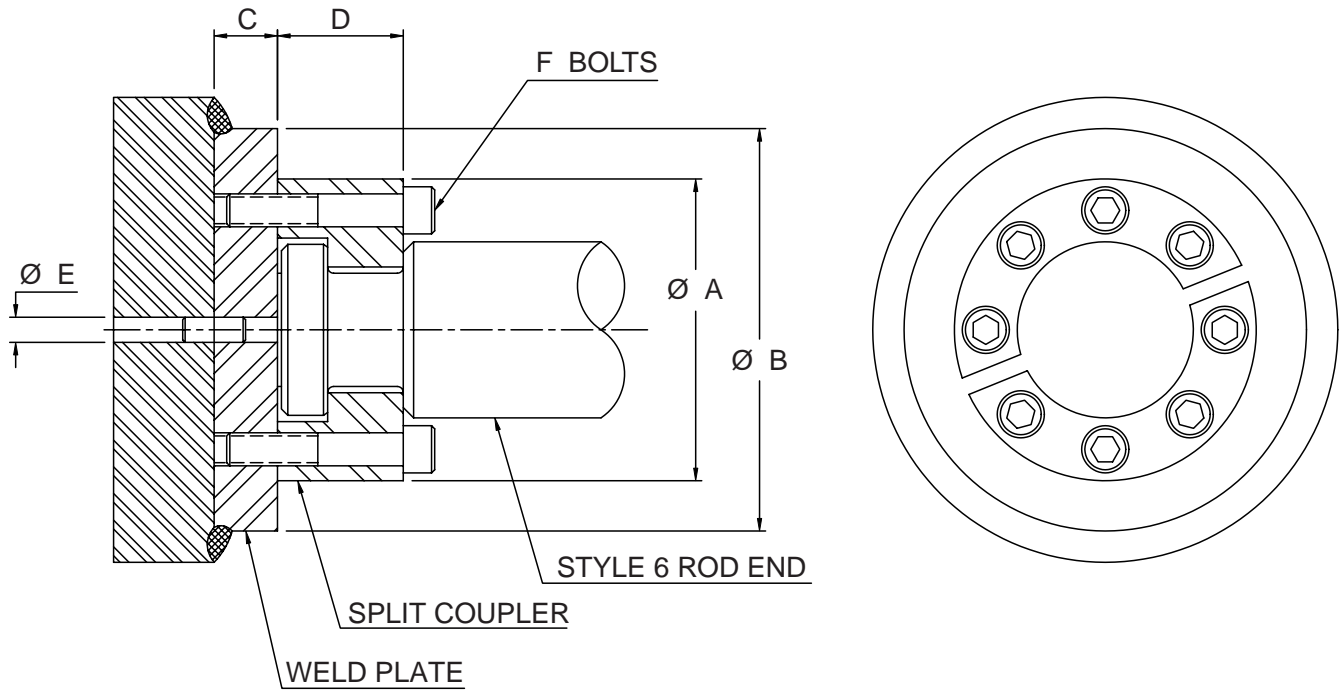

⚠ WARNING: Piston rod separation from the machine member can result in severe personal injury or even death to nearby personnel. The cylinder user must make sure the weld holding the weld plate to the machine is of sufficient quality and size to hold the intended load. The cylinder user must also make sure the bolts holding split coupler to the weld plate are of sufficient strength to hold the intended load and installed in such a way that they will not become loose during the machine's operation.

Table 1 — Part Numbers and Dimensions

Rod Dia	A	B	C	D	E	F	Bolt Size	Bolt Circle	Split Coupler Part No.	Weld Plate Part No.
3	5.00	5.50	1.00	2.38	.375	12	.500-13 x 3.25 LG	4.000	1472340300	1481740300
3½	5.88	7.00	1.00	2.63	.375	12	.625-11 x 3.50 LG	4.687	1472340350	1481740350
4	6.38	7.00	1.00	2.63	.375	12	.625-11 x 3.50 LG	5.187	1472340400	1481740400
4½	6.88	8.00	1.00	3.13	.375	12	.625-11 x 4.00 LG	5.687	1472340450	1481740450
5	7.38	8.00	1.00	3.13	.375	12	.625-11 x 4.00 LG	6.187	1472340500	1481740500
5½	8.25	9.00	1.25	3.88	.375	12	.750-10 x 5.00 LG	6.875	1472340550	1481740550

Note: Screws are not included with split coupler or weld plate.

How to Order PH-3 Series Cylinders

When ordering PH-3 Series cylinders, please review the following:

Note: Duplicate cylinders can be ordered by giving the SERIAL NUMBER from the nameplate of the original cylinder. Factory records supply a quick positive identification.

Piston Rods: Specify model number code based on bore and rod diameter. Give thread style number for a standard thread or specify dimensions. See "Style 0 Rod End" below.

Cushions: If cushions are required specify according to the model number on the next page. If the cylinder is to have a double rod and only one cushion is required, be sure to specify clearly which end of the cylinder is to be cushioned.

Special Modifications: Additional information is required on orders for cylinders with special modifications. This is best handled with descriptive notes. For further information, consult factory.

Lipseal™ Piston (if desired): Schrader Bellows Lipseal™ pistons are offered as an option at no extra cost in the Series PH-3 cylinders. With this feature, zero leakage under static holding conditions is attained. Call out "with Lipseal piston" if this type of piston is desired.

Fluid Medium: Series PH-3 hydraulic cylinders are equipped with seals for use with hydraulic oil. If other than hydraulic oil will be used, specify class of fluid (See Catalog section C.)

See Section C for pressure ratings relating to bore and rod sizes.

Water Service Modifications

When requested, Schrader Bellows can supply PH-3 Series cylinders with standard modifications that make the cylinders suitable for use with water as the fluid medium. The modifications include chrome-plated cylinder bore; electroless nickel-plated, non-wearing internal surfaces; Lipseal style piston, Buna N Seals and chrome-plated, precipitation hardened stainless steel piston rod.

Warranty – Schrader Bellows will warrant Series PH-3 cylinders modified for water or high water content fluid service to be free of defects in materials or workmanship, but cannot accept responsibility for premature failure due to excessive wear resulting from lack of lubricity, where failure is caused by corrosion, electrolysis or mineral deposits within the cylinder.

Class 1 Seals

Class 1 seals are the seals provided as standard in a cylinder assembly unless otherwise specified. For further information on fluid compatibility or operating limitations of all components, see section C.

For the PH-3 series cylinders the following make-up Class 1 Seals:

Primary Piston Rod Seal – Enhanced Polyurethane
Piston Rod Wiper – Nitrile
Piston Seals – Filled PTFE seals with nitrile expander
Option – Cast iron rings
O-Rings – Nitrile (nitrile back-up washer when used)

Style 0 Rod End

A style 0 rod end indicates a special rod end configuration. All special piston rod dimensions must have **all three:** KK; A; W/WF or LA/LAF specified with the rod fully retracted. A sketch or drawing should be submitted for rod ends requiring special machining such as snap ring grooves, keyways, tapers, multiple diameters, etc. It is good design practice to have this machining done on a diameter at least 0.065 inches smaller than the piston rod diameter. This allows the piston rod to have a chamfer preventing rod seal damage during assembly or maintenance.

Standard style 6 rod ends with an extended WG dimension should call out a style 0 rod end and the note: **same as 6 except WG=_____**. A drawing should be submitted for special 6 rod ends that have specific tolerances or special radii. Special rod ends that have smaller than standard male threads, larger than standard female threads, or style 6 rod ends with smaller than standard AF or AE dimensions are to be reviewed by Engineering for proper strength at operating pressure.

Service Policy

On cylinders returned to the factory for repairs, it is standard policy for the Industrial Cylinder Division to make such part replacements as will put the cylinder in as good as new condition. Should the condition of the returned cylinder be such that expenses for repair would exceed the costs of a new one, you will be notified.

Address all correspondence and make shipments to, Service Department at your nearest regional plant listed in the pages of this catalog.

Certified Dimensions

Schrader Bellows Industrial Cylinder Division guarantees that all cylinders ordered from this catalog will be built to dimensions shown. All dimensions are certified to be correct, and thus it is not necessary to request certified drawings.

How to Order By Model Number

7" and 8" PH-3 Hydraulic Cylinders can be specified by model number by using the tables shown at right.

1. TYPE

Select the Model Number Code which identifies the single or double rod end and port specification.

2. BORE & ROD DIAMETER

Select the Model Number Code which identifies the desired bore size and rod diameter combination.

3. MOUNTING & CUSHIONING

Select the Model Number Code which identifies the desired mounting style and cushioning option.

4. ROD END STYLE

Select the Model Number Code which identifies the desired rod end thread style.

5. SEAL TYPE

Complete the model number by selecting the type of seals desired. Hi-Load piston seals are standard.

6. STROKE LENGTH

It is necessary to specify the stroke length desired following the Model Number. For example: PHJA70825 with 6" stroke.

THE EXAMPLE WOULD IDENTIFY:

A single rod end hydraulic cylinder with S.A.E. ports, 8" bore size, 3-1/2" diameter piston rod, side lug mounting, cushioned both ends, with a small male rod end thread, high load piston with Buna-N seals and a 6" stroke.

SPECIFYING THE DESIRED TRUNNION LOCATION: (Style MT4 Mounting)

For cylinders with intermediate trunnion mounting, specify the distance between the piston rod reference point and the centerline of the trunnion pin. (Dimension "X1")

OPTIONAL MOUNTING ACCESSORIES

Specify separately by part number the desired optional mounting or rod end accessories.

SPECIAL MODIFICATIONS

For special modifications other than piston rod end, use "S" in the 10th position of the model number and describe the special feature required.

Example: PHJA70825S 6" Stroke

Ports to be in position # 2.

1	Model Number
Type	PH-3 Series Hydraulic
Single End with SAE Straight Thread Ports	PH
Double End with SAE Straight Thread Ports	PJ
Single End with NPTF Ports	PF
Double End with NPTF Ports	PK
Single End with SAE Flange Ports	PX
Double End with SAE Flange Ports	PY

2	Model Number Code	
Bore Size	Rod Dia.	Code
7"	3"	HA6
	3-1/2"	HA7
	4"	HA8
	5"	HD1
8"	3-1/2"	JA7
	4"	JA8
	5"	JD1
	5-1/2"	JD2

3	Model Number Code				
	NFPA Style	Non-Cush.	Cush. Head	Cush. Cap	Cush. Both
Mounting Style					
Side Lug	MS2	05	06	07	08
Side Tap	MS4	13	14	15	16
Head Rectangular Flange	MF1	21	22	23	24
Cap Rectangular Flange	MF2	25	26	27	28
Head Square Flange	MF5	29	30	31	32
Cap Square Flange	MF6	33	34	35	36
Head Rectangular	ME5	45	46	47	48
Cap Rectangular	ME6	49	50	51	52
Tie Rods Extended Both Ends	MX1	53	54	55	56
Cap Tie Rods Extended	MX2	57	58	59	60
Head Tie Rods Extended	MX3	61	62	63	64
Head Trunnion	MT1	69	70	71	72
Cap Trunnion	MT2	73	74	75	76
Intermediate Fixed Trunnion	MT4	77	78	79	80
Cap Fixed Clevis	MP1	81	82	83	84

4	Rod End Style	Model Number Code
	Small Male	2
	Short Female	3
	Intermediate Male	4
	Special – Specify	0

5	Seal Type	Model Number Code
	Buna N Seals w/Lipseal Piston	1
	Fluorocarbon Seals w/Lipseal Piston	2
	Buna N Seals w/Piston Rings	3
	Fluorocarbon Seals w/Piston Rings	4
	Buna N Seals w/Hi-Load Piston	5
	Fluorocarbon Seals w/Hi-Load Piston	6

6	Specify Stroke Length	6"
----------	------------------------------	-----------

Model Number Example:
PH JA7 08 2 5 w/6"

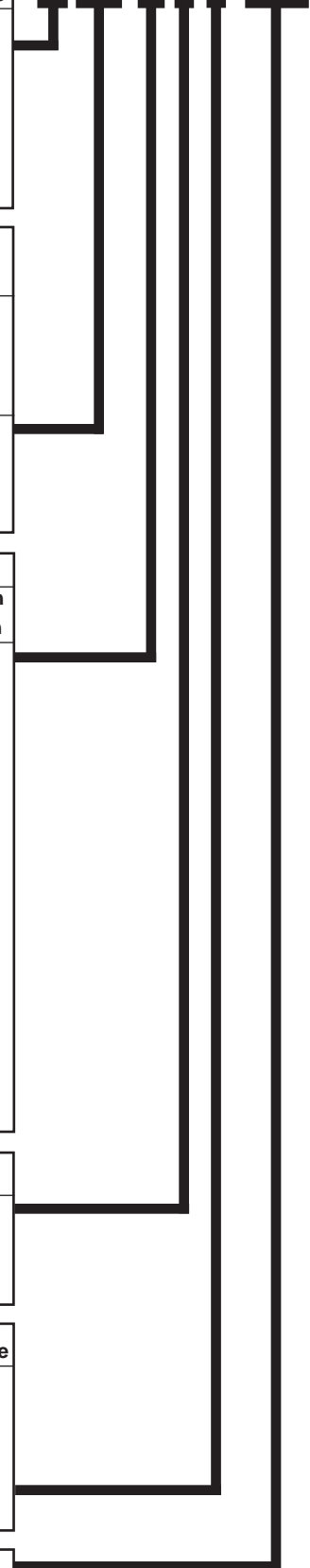

B

PL-2

PH-2

PH-3

PHX

SHM

CHE/CHD

NOTES



Contents

Features	106	Mounting Recommendations	118
Specifications and Mountings	107	“Style 6” Piston Rod End.....	119-120
Design Features.....	108-109	How to Order.....	121
Mounting Information	110-117	Parts I.D. and Seal Kits.....	Sec. C, pgs. 42-43
Double Rod Models	118	Application Engineering Data	Sec. C, pgs. 86-90

B

PL-2

PH-2

PH-3

PHX

SHM

CHE/CHD

The 10" through 20" bore, high pressure dynamic cylinders are designed to meet your needs

In the PH-3 Series cylinder you get unmatched reliability, performance, and innovative design features to help increase productivity and reduce your operating costs.

Schrader Bellows' externally removable bolt-on gland assembly makes preventive maintenance fast...and easy! You **do not** have to disassemble the cylinder, loosen the tie rod nuts, or remove the long cast iron rod bearing to replace the Polypak™ double bevel lipseal and double service Wiperseal. The ruggedly constructed gland assembly includes the ultimate in sealing for extra heavy duty applications in most any industry. The high pressure large bore PH-3 Series hydraulic cylinder also includes the innovative anti-extrusion

body end seal design...where the heads and caps are specially machined **to prevent** extrusion of the body end seals and insure against leakage — PLUS...Every cylinder is individually tested before it leaves our plant.

For quick delivery, the PH-3 Series is available to you from our regional plant system. Select **genuine** cylinder replacement parts are stocked by local Schrader Bellows distributors from coast-to-coast.

See the following pages for all the features that make the Schrader Bellows PH-3 Series your best choice for all your large bore high pressure hydraulic cylinder applications...

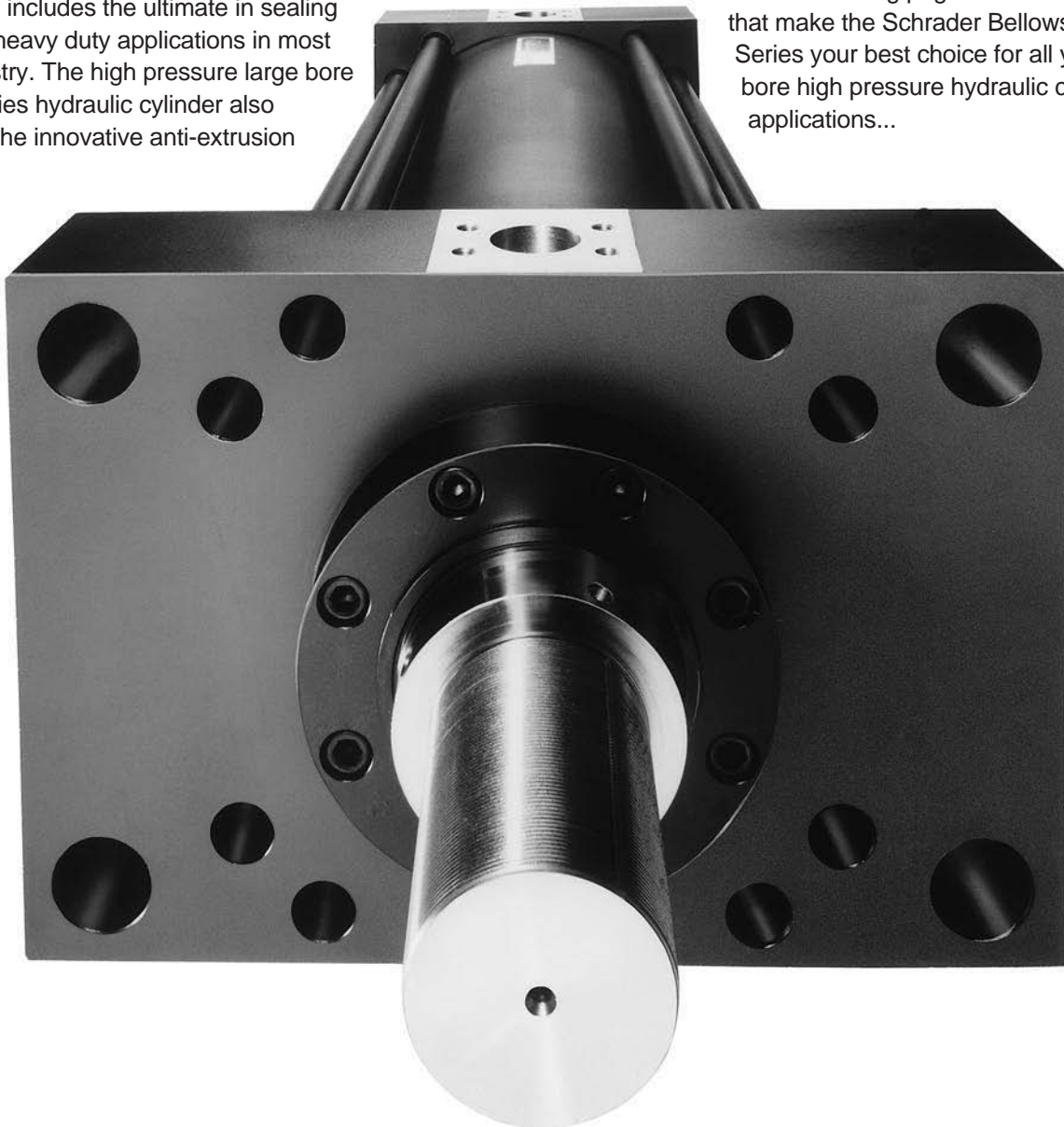

Standard Specifications

- Heavy Duty Service
- Standard Construction – Square Head – Tie Rod Design
- Nominal Pressure – 3000 PSI*
- Standard Fluid – Hydraulic Oil
- Standard Temperature -10°F. to +165°F.**
- Bore Sizes – 10" through 20" (Larger sizes available)
- Piston Rod Diameter – 4 1/2" through 10"

- Mounting Styles – 12 standard styles at various application ratings
- Strokes – Available in any practical stroke length
- Cushions – Optional at either end or both ends of stroke
- Rod Ends – Two Standard Choices – Specials to Order

*If hydraulic operating pressure exceeds 3000 PSI, send application data for engineering evaluation and recommendation. See Engineering Section for actual design factors.

**See Engineering Section for higher temperature service.

In line with our policy of continuing product improvement, specifications in this catalog are subject to change.

Available Mounting Styles

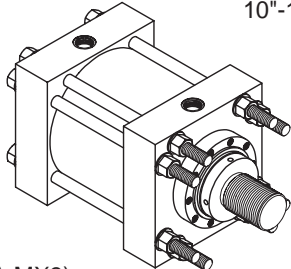
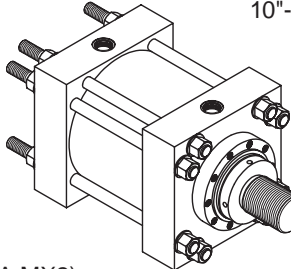
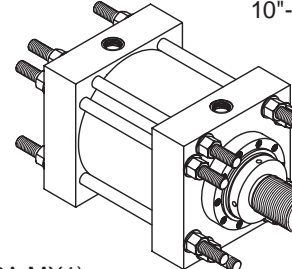
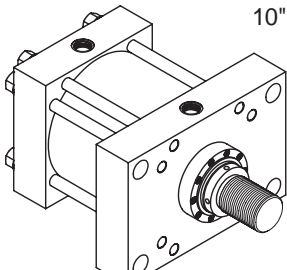
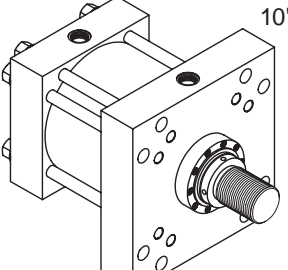
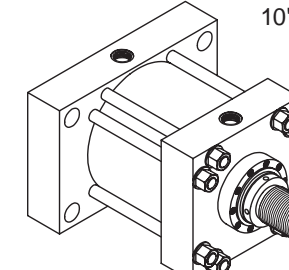
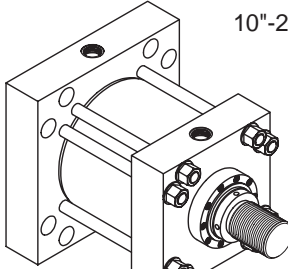
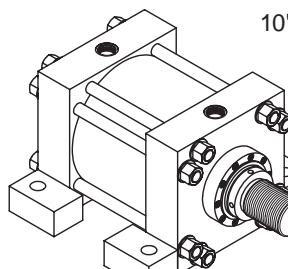
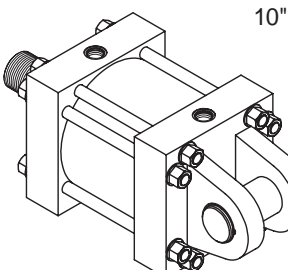
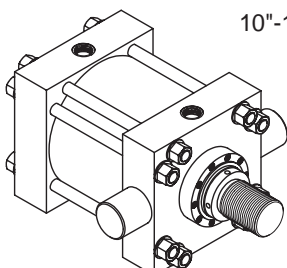
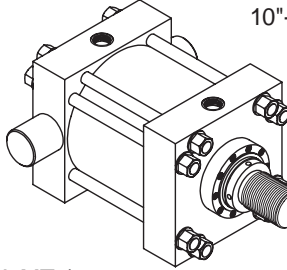
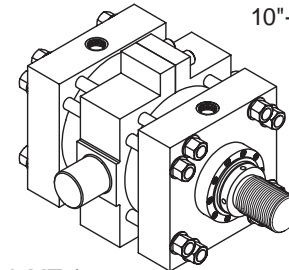
<p>Tie Rods Extended Head End 10"-14" Bore</p>  <p>(NFPA MX3)</p>	<p>Tie Rods Extended Cap End 10"-14" Bore</p>  <p>(NFPA MX2)</p>	<p>Tie Rods Extended Both Ends 10"-14" Bore</p>  <p>(NFPA MX1)</p>
<p>Head Rectangular 10"-20" Bore</p>  <p>(NFPA ME5)</p>	<p>Head Square Flange 10"-20" Bore</p>  <p>(NFPA MF5)</p>	<p>Cap Rectangular 10"-20" Bore</p>  <p>(NFPA ME6)</p>
<p>Cap Square 10"-20" Bore</p>  <p>(NFPA MF6)</p>	<p>Side Lug 10"-14" Bore</p>  <p>(NFPA MS2)</p>	<p>Cap Fixed Clevis 10"-20" Bore</p>  <p>(NFPA MP1)</p>
<p>Head Trunnion 10"-14" Bore</p>  <p>(NFPA MT1)</p>	<p>Cap Trunnion 10"-14" Bore</p>  <p>(NFPA MT2)</p>	<p>Intermediate Fixed Trunnion 10"-14" Bore</p>  <p>(NFPA MT4)</p>

B

PL-2

PH-2

PH-3

PHX

SHM

CHE/CHD

These innovative design features make the PH-3 Series your best choice for all your large bore, high pressure hydraulic cylinder applications.

Primary Seal – Polypak™ double-bevel lip design combines ease of installation with rugged construction. The ultimate seal in extra heavy duty applications. Completely self-compensating and self-relieving to withstand pressure variations and conform to mechanical deflection that may occur.

Secondary Seal – Double-Service Wiperseal™ wipes clean any oil film adhering to the rod on the extend stroke and cleans the rod on the return stroke.

Bolt-On Rod Gland Assembly – Externally removable without cylinder disassembly. Long cast-iron bearing surface is inboard of the seals, assuring positive lubrication from within the cylinder. An “O” ring is used as a seal between gland and head.

Steel Head – Bored and grooved to provide concentricity for mating parts.

Alloy Steel Tie Rod Nuts – With hardened washer.

High Strength Tie Rods – Made from 100,000 PSI minimum yield steel with rolled threads for added strength.

Piston Rod – Hard chrome-plated and polished for maximum seal and rod bearing life. Two standard thread styles. Rod end is supplied with spanner wrench holes.

End Seals – Pressure-actuated cylinder body-to-head and cap “O” rings and back-up washers.

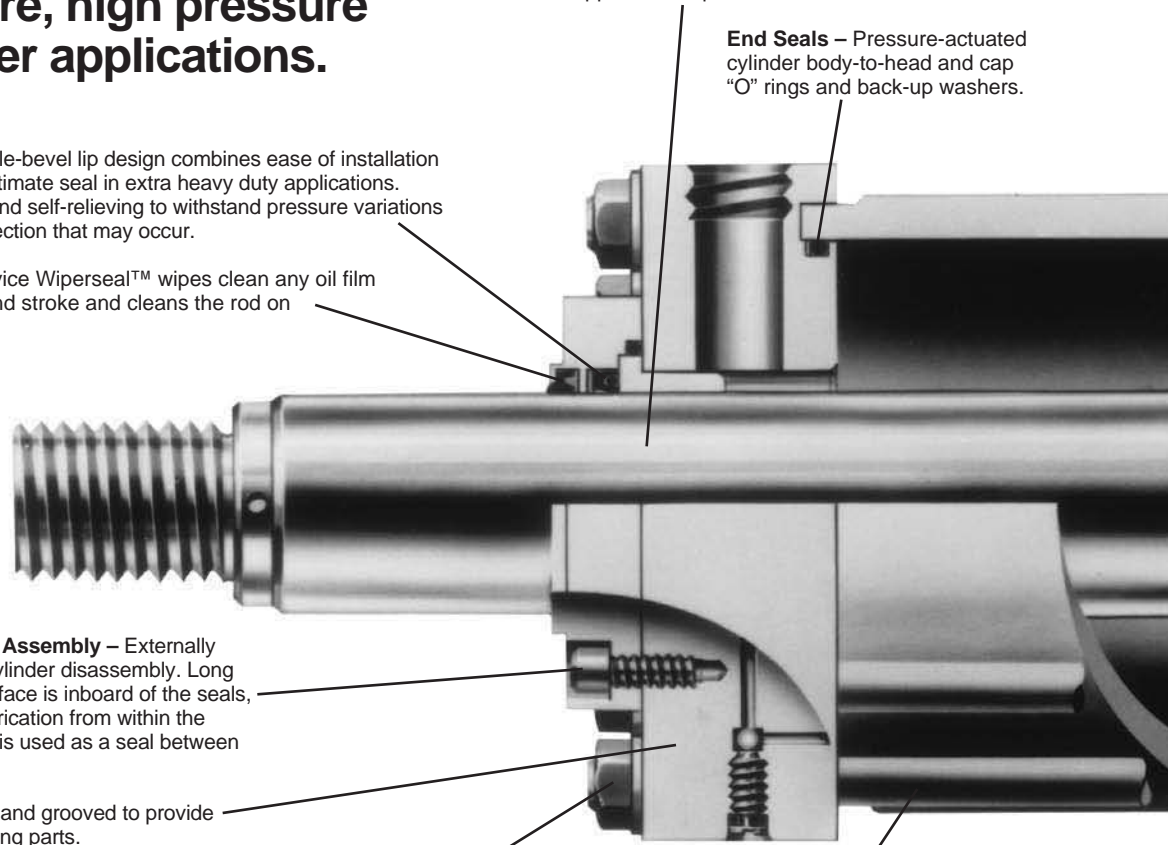

Stepped floating cushions combine the best features of known cushion technology.

Deceleration devices or built-in “cushions” are optional and can be supplied at head end, cap end, or both ends without change in envelope or mounting dimensions. Standard straight or tapered cushions have been used in industrial cylinders over a very broad range of applications. Research has found that both designs have limitations.

As a result, we have taken a new approach in cushioning of industrial hydraulic cylinders and for specific load and velocity conditions have been able to obtain deceleration curves that come very close to the ideal. The success lies in a stepped sleeve or spear concept where the steps are calculated to approximate theoretical orifice areas. In the cushion performance chart, pressure traces show the results of typical orifice flow conditions. Tests of a three-step sleeve or spear show three pressure pulses coinciding with the steps. The deceleration curve shape comes very close to being theoretical, with the exception of the last 1/2" of travel. This is a constant shape in order to have some flexibility in application. The stepped cushion design shows reduced pressure peaks for most load and speed conditions, with comparable reduction of objectionable stopping forces being transmitted to the load and the support structure.

The PH3 Series design incorporates the longest cushion sleeve and cushion spear that can be provided in the standard envelope without decreasing the rod bearing and piston bearing strengths.

- (1) When a cushion is specified at the head end:
- A stepped sleeve is furnished on the piston rod assembly.
 - A needle valve is provided that is flush with the side of the head even when wide open. It may be identified by the fact that it is socket-keyed. It is located on side number 3, in all mounting styles except the MS2. In this style it is located on side number 2.

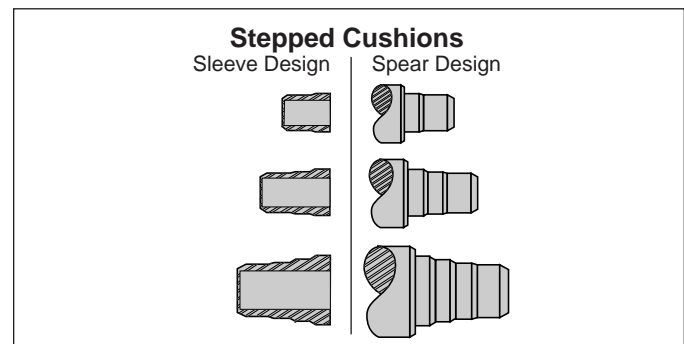

Adjustable Floating Stepped Cushions – For maximum performance. Economical and flexible for even the most demanding applications. Provides superior performance in reducing shock. Cushions are optional and can be supplied at head end, cap end, or both ends without change in envelope or mounting dimensions.

Align-A-Groove™ – A $\frac{3}{16}$ " wide surface machined at each end of the cylinder body. Makes precise mounting quick and easy.

Hi-Load Piston Seals – Are standard.

Ports – SAE O ring straight thread ports are standard.

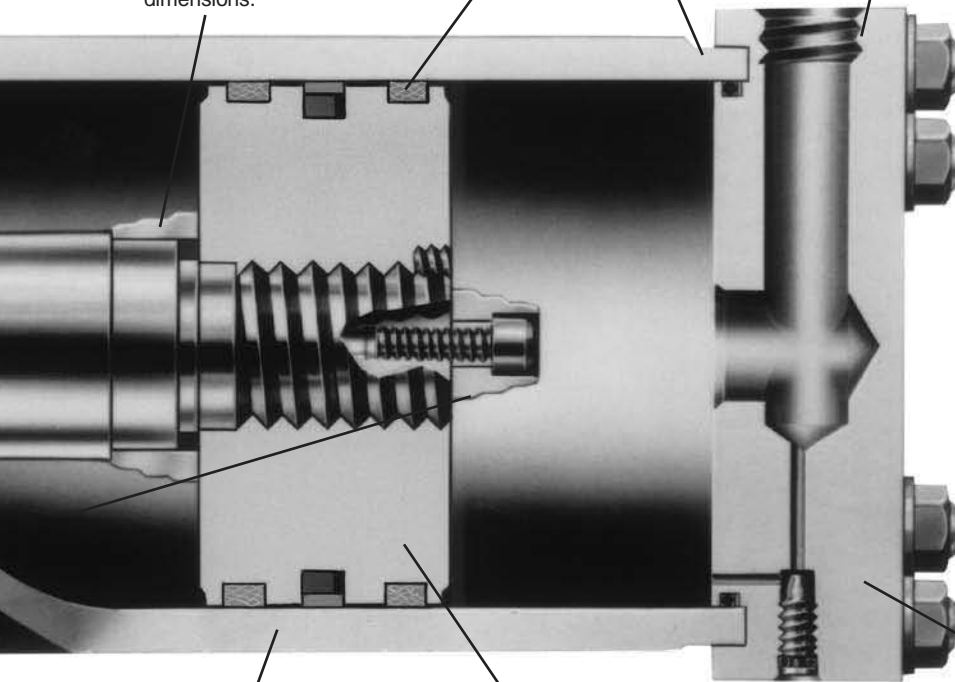

The Cylinder Body – Heavy-wall steel tubing is honed to a 15 RMS micro finish bore providing a wear surface for long lasting piston bearing and seal life.

One-Piece Nodular Iron Piston – The wide piston surface contacting cylinder bore reduces bearing loads. One piece design is piloted to piston rod assuring concentricity. Piston is locked with set screw. Anaerobic adhesive and peening of set screw locks and seals piston to rod.

Optional Piston

Piston Ring Piston – With Step Cut Iron Piston Ring optional

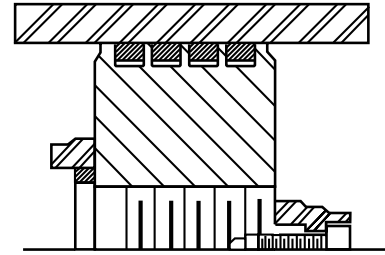

Optional Ports – SAE straight thread ports or NPTF (Dry Seal Pipe Ports) are available at no charge. Optional SAE flange, BSP, BSPT, and Metric ports are available for an extra charge. (See ports, Application Engineering Data page in Section C.)

Seals – Buna-N (Nitrile) seals standard.

Fluorocarbon Seals – Optional at extra charge.

Steel Cap – Bored and grooved to provide concentricity for mating parts.

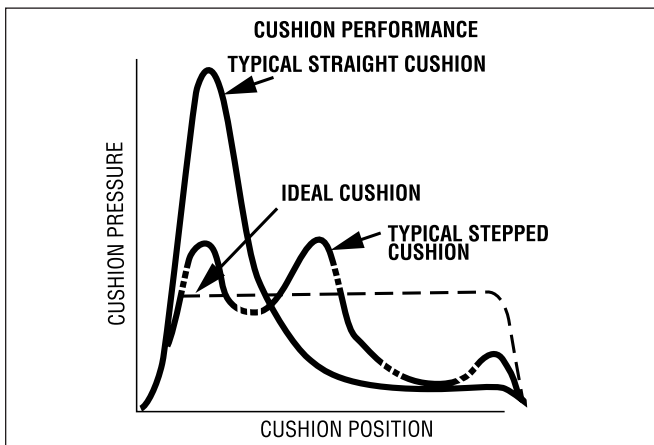

(2) When a cushion is specified at the cap end:

- a. A cushion-stepped spear is provided on the piston rod.
- b. A socket-keyed needle valve is provided that is flush with the side of the cap when wide open. It is located on side number 3 in all mounting styles except the MS2. In this style it is located on side number 2.
- c. A springless check valve is provided that is also flush with the side of the cap and is mounted on the same side as the needle valve except on mounting style MS2, where it is mounted on side number 2, next to the needle valve.
- d. The check and needle valves are interchangeable in the cap.

- c. A springless check valve is provided that is also flush with the side of the head and is mounted on the same side as the needle valve except on mounting style MS2 where it is mounted on side number 2, next to the needle valve. It may be identified by the fact that it is slotted.
- d. The check and needle valves are interchangeable in the head.

**Tie Rods Extended Head End Mount
(NFPA Style MX3)**

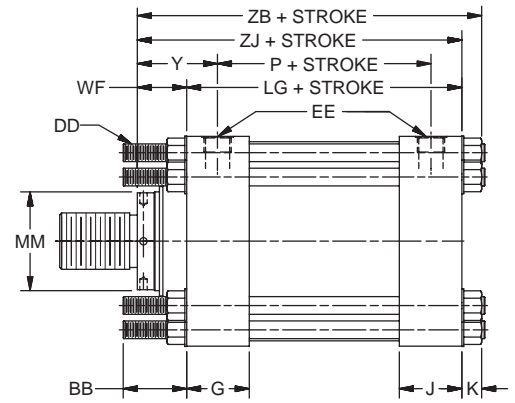
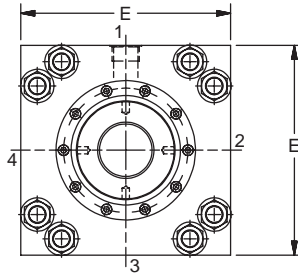
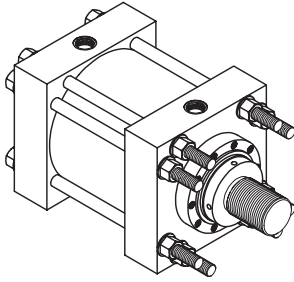

**Tie Rods Extended Cap End Mount
(NFPA Style MX2)**

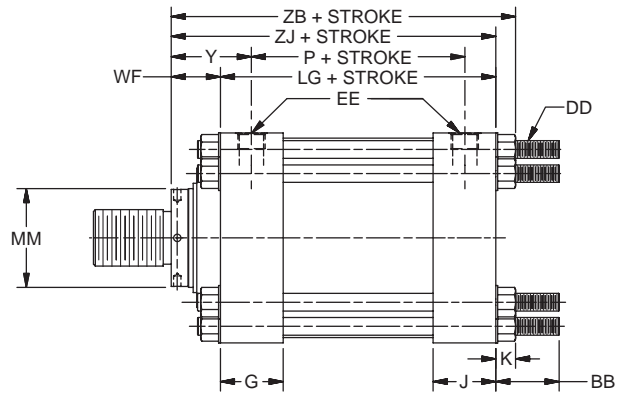
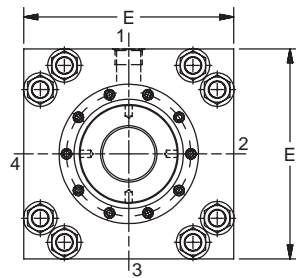
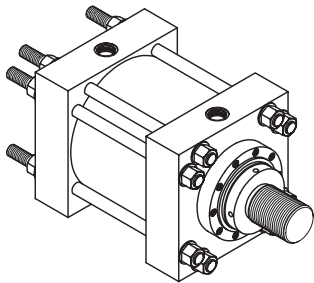

**Tie Rods Extended
Both Ends Mount
(NFPA Style MX1)**

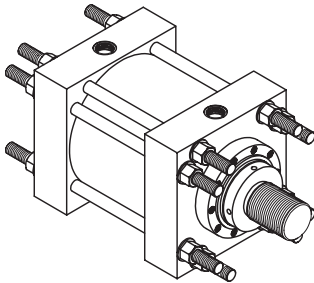

Basic Mounting (MX0) — Not shown is no tie rod extended and can be supplied upon request.

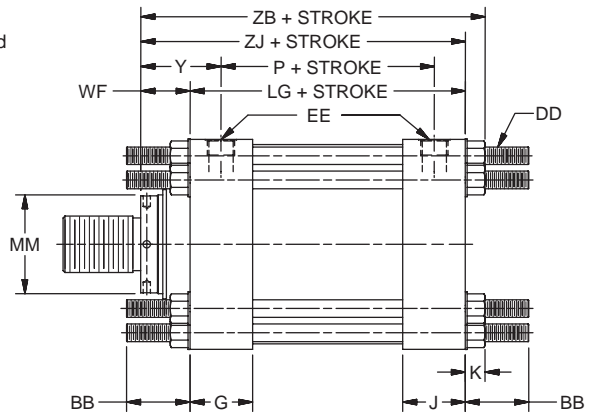
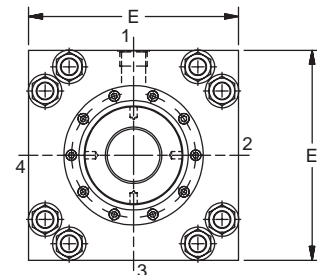

Rod End Dimensions — see table 2

**Thread Style 2
(NFPA Style SM)
Small Male**

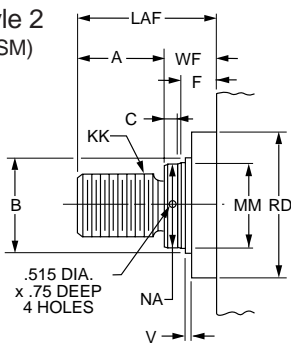

If rod end is not specified, Style 2 will be furnished.

**Thread Style 3
(NFPA Style SF)
Short Female**

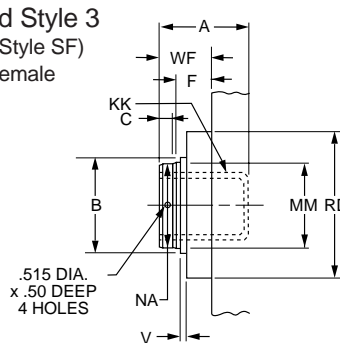

Use Style 3 for applications where female rod ends are required.

**Special Thread
Style 0**

Special thread, extension, rod eye, blank, etc., are also available.

To order, specify "Style 0" and give desired dimensions for KK, A and WF.

If otherwise special, furnish dimensional sketch.

Style 3 stroke restrictions may apply. See Style 3 Minimum Stroke page for details.

Table 1—Envelope and Mounting Dimensions

Bore	BB	DD	E	EE* NPTF	EEf▲ S.A.E. FLANGE PORT	EE** S.A.E. STRAIGHT THREAD	G	J	K	RA	RB	RC	RR	Add Stroke	
														LG	P
10	4 ¹ / ₈	1 ¹ / ₈ -12	12 ⁵ / ₈	2	2	24	3 ¹¹ / ₁₆	3 ¹¹ / ₁₆	1 ⁹ / ₃₂	5.291	3.775	—	2 ¹ / ₈	12 ¹ / ₈	8 ¹ / ₂
12	4 ¹ / ₂	1 ¹ / ₄ -12	14 ⁷ / ₈	2 ¹ / ₂	2 ¹ / ₂	24	4 ⁷ / ₁₆	4 ⁷ / ₁₆	1 ¹³ / ₃₂	6.270	4.555	—	2 ³ / ₈	14 ¹ / ₂	10 ¹ / ₈
14	4 ¹ / ₂	1 ¹ / ₄ -12	17 ¹ / ₈	2 ¹ / ₂	2 ¹ / ₂	24	4 ⁷ / ₈	4 ⁷ / ₈	1 ¹³ / ₃₂	7.485	6.143	4.409	2 ¹ / ₄	15 ⁵ / ₈	10 ⁷ / ₈

* NPTF ports are available at no extra charge.

▲ Optional SAE flange ports may be specified – flange to be supplied by customer. See Table 4 for flange port pattern dimensions.

** SAE straight thread ports are standard and are indicated by port number.

Table 2—Rod Dimensions

Bore	Rod Dia. MM	Thread KK	Rod Extensions and Pilot Dimensions									Add Stroke		
			A	+0.000 -0.005 B	C	F	LAF	NA	RD	V	WF	Y	ZB	ZJ
10	4 ¹ / ₂	3 ³ / ₄ -12	4 ¹ / ₂	5.249	1	1 ¹⁵ / ₁₆	7 ⁷ / ₁₆	4 ³ / ₈	8 ¹ / ₄	1 ¹ / ₄	2 ¹⁵ / ₁₆	4 ³ / ₄	16 ¹¹ / ₃₂	15 ¹ / ₁₆
	7	5-12	7	7.999	1	1 ¹⁵ / ₁₆	10 ¹ / ₂	6 ⁷ / ₈	10 ¹ / ₂	3 ³ / ₈	3 ¹ / ₂	5 ⁵ / ₁₆	16 ²⁹ / ₃₂	15 ⁵ / ₈
	5	3 ¹ / ₂ -12	5	5.749	1	1 ¹⁵ / ₁₆	8 ³ / ₁₆	4 ⁷ / ₈	8 ⁷ / ₈	1 ¹ / ₄	3 ³ / ₁₆	5	16 ¹⁹ / ₃₂	15 ⁵ / ₁₆
	5 ¹ / ₂	4-12	5 ¹ / ₂	6.249	1	1 ¹⁵ / ₁₆	8 ¹¹ / ₁₆	5 ³ / ₈	9 ³ / ₈	1 ¹ / ₄	3 ³ / ₁₆	5	16 ¹⁹ / ₃₂	15 ⁵ / ₁₆
12	5 ¹ / ₂	4-12	5 ¹ / ₂	6.249	1	1 ¹⁵ / ₁₆	8 ¹¹ / ₁₆	5 ³ / ₈	9 ³ / ₈	1 ¹ / ₄	3 ³ / ₁₆	5 ³ / ₈	19 ⁹ / ₃₂	17 ¹¹ / ₁₆
	8	5 ³ / ₄ -12	8	8.999	1	1 ¹⁵ / ₁₆	12	7 ⁷ / ₈	12 ¹ / ₂	3 ³ / ₈	4	6 ³ / ₁₆	19 ²⁹ / ₃₂	18 ¹ / ₂
	7	5-12	7	7.999	1	1 ¹⁵ / ₁₆	10 ¹ / ₂	6 ⁷ / ₈	10 ¹ / ₂	3 ³ / ₈	3 ¹ / ₂	5 ¹¹ / ₁₆	19 ¹³ / ₃₂	18
14	7	5-12	7	7.999	1	1 ¹⁵ / ₁₆	10 ¹ / ₂	6 ⁷ / ₈	10 ¹ / ₂	3 ³ / ₈	3 ¹ / ₂	5 ⁷ / ₈	20 ¹⁷ / ₃₂	19 ¹ / ₈
	10	7 ¹ / ₄ -12	10	10.999	1	1 ¹⁵ / ₁₆	14 ¹ / ₂	9 ⁷ / ₈	14 ¹ / ₂	3 ³ / ₈	4 ¹ / ₂	6 ⁷ / ₈	21 ¹⁷ / ₃₂	20 ¹ / ₈
	8	5 ³ / ₄ -12	8	8.999	1	1 ¹⁵ / ₁₆	12	7 ⁷ / ₈	12 ¹ / ₂	3 ³ / ₈	4	6 ³ / ₈	21 ¹ / ₃₂	19 ⁵ / ₈

Table 3 —
Envelope and
Mounting
Dimensions

Table 4—Optional SAE Flange Port Pattern

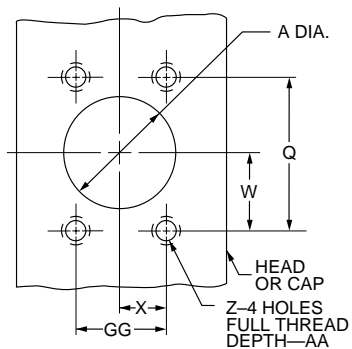

Nom. Flange Size	S.A.E. Flange Dash Size	A	Q	GG	W	X	Z-THD UNC-2B	AA Min.
1 ¹ / ₂	- 24	1.50	2.750	1.406	1.38	0.70	1/2-13	1.06
2	- 32	2.00	3.062	1.688	1.53	0.84	1/2-13	1.06
2 ¹ / ₂	- 40	2.50	3.500	2.000	1.75	1.00	1/2-13	1.19
3	- 48	3.00	4.188	2.438	2.09	1.22	5/8-11	1.19

Table 5—Tie Rod Information
see table 1 for dimensions

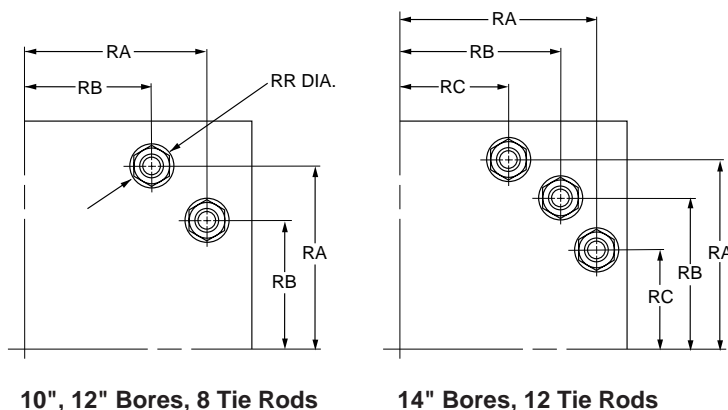

Head Rectangular Mount
(10"-14" Bore)
(NFPA Style ME5)

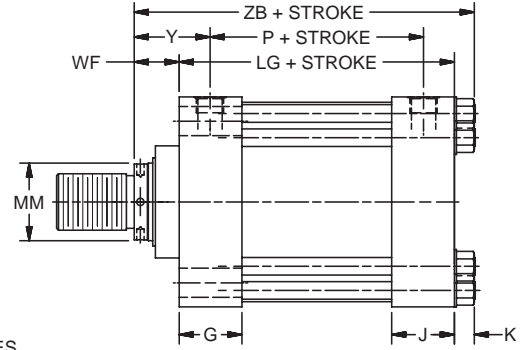
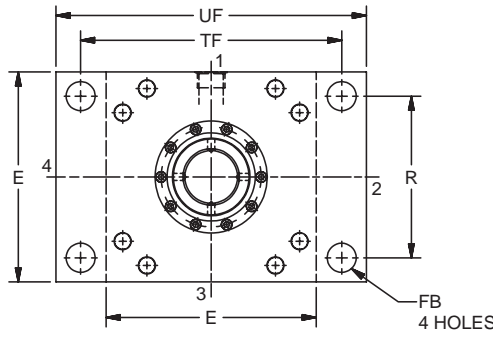
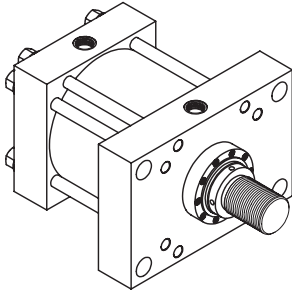

Head Rectangular Mount
(16"-20" Bore)
(NFPA Style ME5)

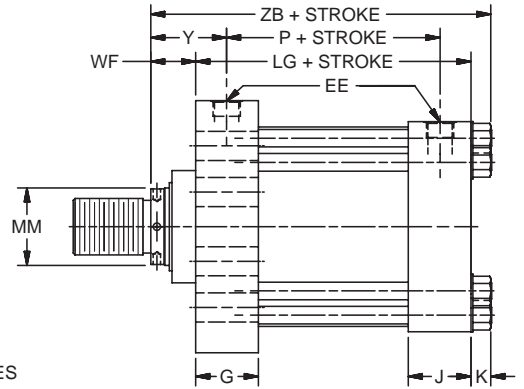
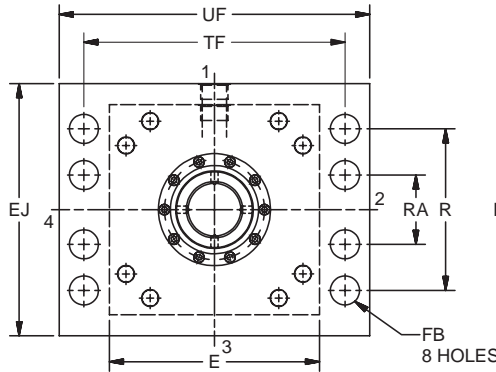
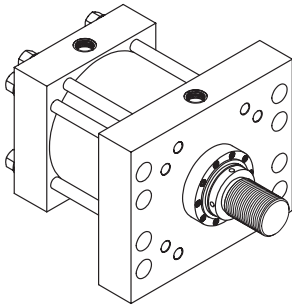

Head Square Mount
(NFPA Style MF5)

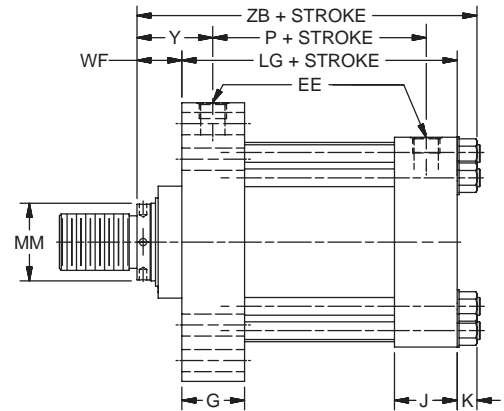
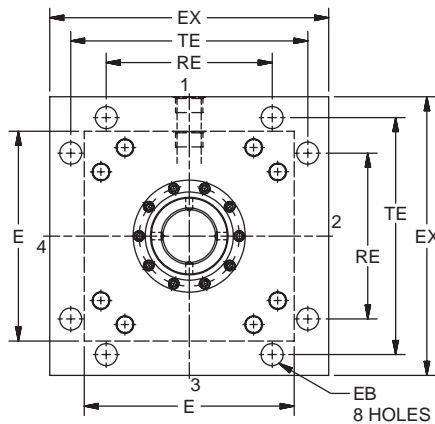
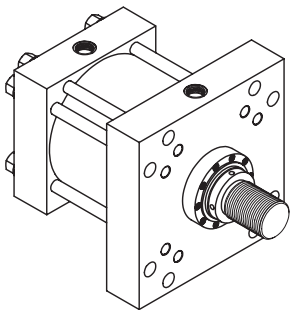

Rod End Dimensions — see table 2

Thread Style 2
(NFPA Style SM)
Small Male

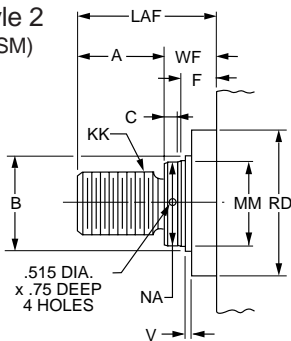

If rod end is not specified, Style 2 will be furnished.

Thread Style 3
(NFPA Style SF)
Short Female

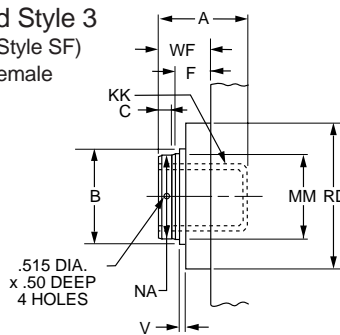

Use Style 3 for applications where female rod ends are required.

Special Thread Style 0

Special thread, extension, rod eye, blank, etc., are also available.

To order, specify "Style 0" and give desired dimensions for KK, A and WF.

If otherwise special, furnish dimensional sketch.

Style 3 stroke restrictions may apply. See Style 3 Minimum Stroke page for details.

Table 1—Envelope and Mounting Dimensions

Bore	E	EB	EE* NPTF	EE [▲] S.A.E. FLANGE PORT	EE** S.A.E. STRAIGHT THREAD	EX	FB	G	J	K	R	RE	TE	TF	UF	Add Stroke	
																LG	P
10	12 ⁵ / ₈	1 ⁵ / ₁₆	2	2	24	16 ⁵ / ₈	1 ¹³ / ₁₆	3 ¹¹ / ₁₆	3 ¹¹ / ₁₆	1 ⁹ / ₃₂	9.62	9.89	14.13	15 ⁷ / ₈	19	12 ¹ / ₈	8 ¹ / ₂
12	14 ⁷ / ₈	1 ⁹ / ₁₆	2 ¹ / ₂	2 ¹ / ₂	24	19 ³ / ₄	2 ¹ / ₁₆	4 ⁷ / ₁₆	4 ⁷ / ₁₆	1 ¹³ / ₃₂	11.45	11.75	16.79	18 ¹ / ₂	22	14 ¹ / ₂	10 ¹ / ₈
14	17 ¹ / ₈	1 ¹³ / ₁₆	2 ¹ / ₂	2 ¹ / ₂	24	21 ³ / ₄	2 ⁵ / ₁₆	4 ⁷ / ₈	4 ⁷ / ₈	1 ¹³ / ₃₂	13.26	12.90	18.43	21	25	15 ⁵ / ₈	10 ⁷ / ₈

Table 1A—Envelope and Mounting Dimensions

Bore	E	EB	EE (SAE)	EE (FLANGE)	EJ	EX	FB	G	J	K	R	RA	RE	TE	TF	UF	Add Stroke	
																	LG	P
16	19	1 ¹³ / ₁₆	24	3	20	24 ¹ / ₂	1 ¹³ / ₁₆	5 ⁷ / ₈	5 ⁷ / ₈	1 ²⁹ / ₃₂	15 ¹ / ₂	8	15.28	21.03	21	24 ¹ / ₂	18 ¹ / ₈	12 ¹ / ₈
18	22	2 ¹ / ₁₆	24	3	23	26 ¹ / ₂	2 ¹ / ₁₆	6 ⁷ / ₈	6 ⁷ / ₈	1 ²⁹ / ₃₂	18	7 ¹ / ₄	16.45	22.65	24 ¹ / ₄	28 ¹ / ₄	21 ¹ / ₈	15 ¹ / ₈
20	24	2 ¹ / ₁₆	24	3	25	29	2 ¹ / ₁₆	7 ⁷ / ₈	7 ⁷ / ₈	1 ²⁹ / ₃₂	20	8	18.07	24.87	26 ¹ / ₂	30 ¹ / ₂	23 ⁵ / ₈	17 ⁵ / ₈

* NPTF ports are available at no extra charge.

▲ Optional SAE flange ports may be specified – flange to be supplied by customer. See Table 4 for flange port pattern dimensions.

** SAE straight thread ports are standard and are indicated by port number.

Table 2—Rod Dimensions

Bore	Rod Dia. MM	Thread KK	Rod Extensions and Pilot Dimensions										Add Stroke	
			A	+0.000 -0.005 B	C	F	LAF	NA	RD	V	WF	Y	ZB	
10	4 ¹ / ₂	3 ¹ / ₄ -12	4 ¹ / ₂	5.249	1	1 ¹⁵ / ₁₆	7 ⁷ / ₁₆	4 ³ / ₈	8 ¹ / ₄	1 ¹ / ₄	2 ¹⁵ / ₁₆	4 ³ / ₄	16 ¹¹ / ₃₂	
	7	5-12	7	7.999	1	1 ¹⁵ / ₁₆	10 ¹ / ₂	6 ⁷ / ₈	10 ¹ / ₂	3 ³ / ₈	3 ¹ / ₂	5 ⁵ / ₁₆	16 ²⁹ / ₃₂	
	5	3 ¹ / ₂ -12	5	5.749	1	1 ¹⁵ / ₁₆	8 ³ / ₁₆	4 ⁷ / ₈	8 ⁷ / ₈	1 ¹ / ₄	3 ³ / ₁₆	5	16 ¹⁹ / ₃₂	
	5 ¹ / ₂	4-12	5 ¹ / ₂	6.249	1	1 ¹⁵ / ₁₆	8 ¹¹ / ₁₆	5 ³ / ₈	9 ³ / ₈	1 ¹ / ₄	3 ³ / ₁₆	5	16 ¹⁹ / ₃₂	
12	5 ¹ / ₂	4-12	5 ¹ / ₂	6.249	1	1 ¹⁵ / ₁₆	8 ¹¹ / ₁₆	5 ³ / ₈	9 ³ / ₈	1 ¹ / ₄	3 ³ / ₁₆	5 ³ / ₈	19 ³ / ₃₂	
	8	5 ³ / ₄ -12	8	8.999	1	1 ¹⁵ / ₁₆	12	7 ⁷ / ₈	12 ¹ / ₂	3 ³ / ₈	4	6 ³ / ₁₆	19 ²⁹ / ₃₂	
	7	5-12	7	7.999	1	1 ¹⁵ / ₁₆	10 ¹ / ₂	6 ⁷ / ₈	10 ¹ / ₂	3 ³ / ₈	3 ¹ / ₂	5 ¹¹ / ₁₆	19 ¹³ / ₃₂	
14	7	5-12	7	7.999	1	1 ¹⁵ / ₁₆	10 ¹ / ₂	6 ⁷ / ₈	10 ¹ / ₂	3 ³ / ₈	3 ¹ / ₂	5 ⁷ / ₈	20 ¹⁷ / ₃₂	
	10	7 ¹ / ₄ -12	10	10.999	1	1 ¹⁵ / ₁₆	14 ¹ / ₂	9 ⁷ / ₈	14 ¹ / ₂	3 ³ / ₈	4 ¹ / ₂	6 ⁷ / ₈	21 ¹⁷ / ₃₂	
	8	5 ³ / ₄ -12	8	8.999	1	1 ¹⁵ / ₁₆	12	7 ⁷ / ₈	12 ¹ / ₂	3 ³ / ₈	4	6 ³ / ₈	21 ¹ / ₃₂	
16	8	5 ³ / ₄ -12	8	8.999	1	1 ¹⁵ / ₁₆	12	7 ⁷ / ₈	12 ¹ / ₂	3 ³ / ₈	4	7	24 ¹ / ₃₂	
	9	6 ¹ / ₂ -12	9	9.999	1	1 ¹⁵ / ₁₆	13 ¹ / ₄	8 ⁷ / ₈	13 ¹ / ₂	3 ³ / ₈	4 ¹ / ₄	7 ¹ / ₄	24 ⁹ / ₃₂	
	10	7 ¹ / ₄ -12	10	10.999	1	1 ¹⁵ / ₁₆	14 ¹ / ₂	9 ⁷ / ₈	14 ¹ / ₂	3 ³ / ₈	4 ¹ / ₂	7 ¹ / ₂	24 ¹⁷ / ₃₂	
18	9	6 ¹ / ₂ -12	9	9.999	1	1 ¹⁵ / ₁₆	13 ¹ / ₄	8 ⁷ / ₈	13 ¹ / ₂	3 ³ / ₈	4 ¹ / ₄	7 ¹ / ₄	27 ⁹ / ₃₂	
	10	7 ¹ / ₄ -12	10	10.999	1	1 ¹⁵ / ₁₆	14 ¹ / ₂	9 ⁷ / ₈	14 ¹ / ₂	3 ³ / ₈	4 ¹ / ₂	7 ¹ / ₂	27 ¹⁷ / ₃₂	
20	10	7 ¹ / ₄ -12	10	10.999	1	1 ¹⁵ / ₁₆	14 ¹ / ₂	9 ⁷ / ₈	14 ¹ / ₂	3 ³ / ₈	4 ¹ / ₂	7 ¹ / ₂	30 ¹ / ₃₂	

Table 3—Envelope and Mounting Dimensions

Table 4—Optional SAE Flange Port Pattern

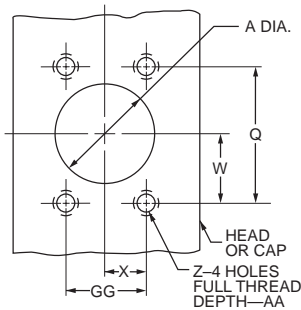

Nom. Flange Size	S.A.E. Flange Dash Size	A	Q	GG	W	X	Z-THD UNC-2B	AA Min.
1 ¹ / ₂	- 24	1.50	2.750	1.406	1.38	0.70	1/2-13	1.06
2	- 32	2.00	3.062	1.688	1.53	0.84	1/2-13	1.06
2 ¹ / ₂	- 40	2.50	3.500	2.000	1.75	1.00	1/2-13	1.19
3	- 48	3.00	4.188	2.438	2.09	1.22	5/8-11	1.19

Table 5—Tie Rod Information

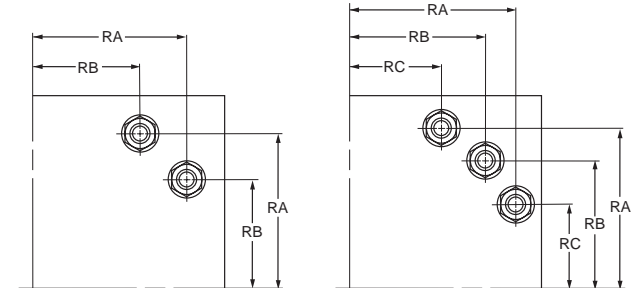

Bore	10	12	14	16	18	20
Tie Rod Thread	1 ¹ / ₈ -12	1 ¹ / ₄ -12	1 ¹ / ₄ -12	*	*	*
RA	5.291	6.270	7.485	*	*	*
RB	3.775	4.555	6.143	*	*	*
RC	—	—	4.409	*	*	*

*Consult factory for dimensions

**Cap Rectangular Mount
10"-14" Bore
(NFPA Style ME6)**

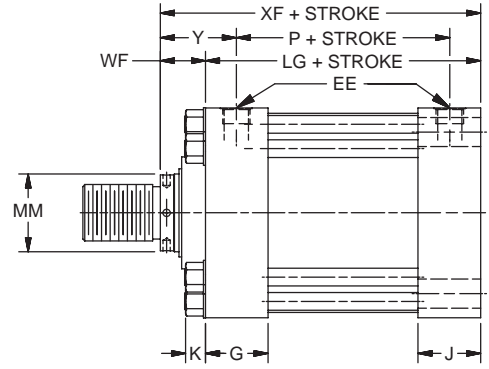
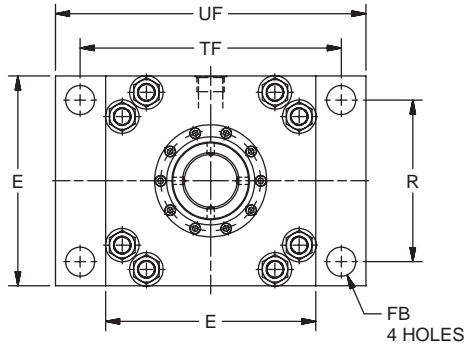
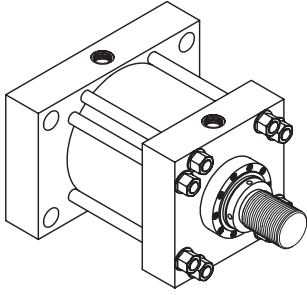

**Cap Rectangular Mount
16"-20" Bore
(NFPA Style ME6)**

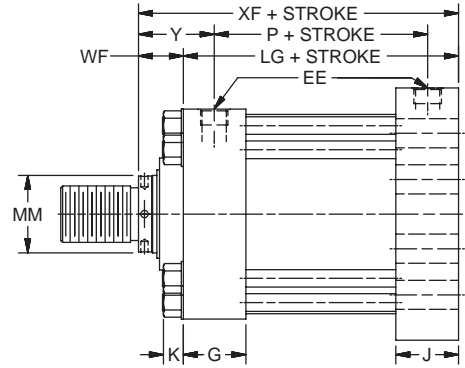
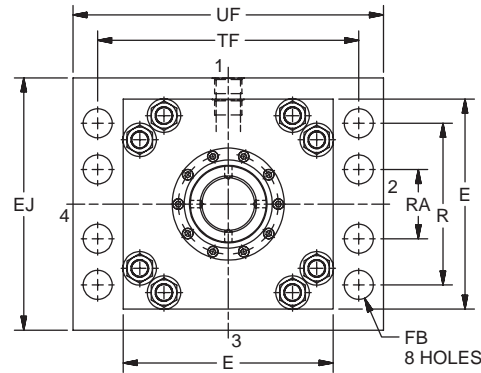
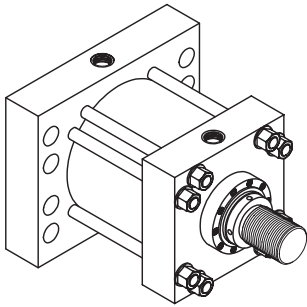

**Cap Square Mount
(NFPA Style MF6)**

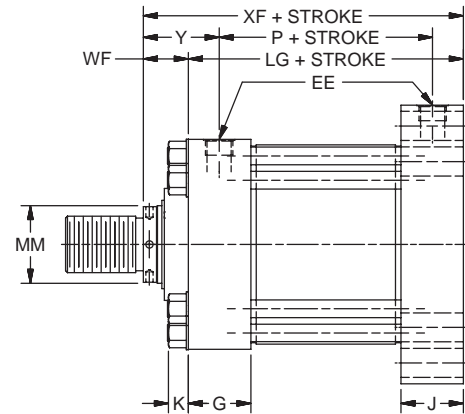
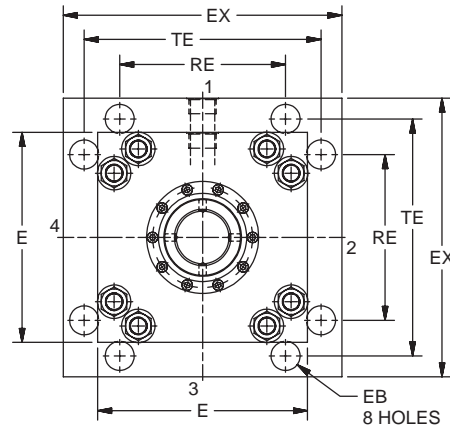
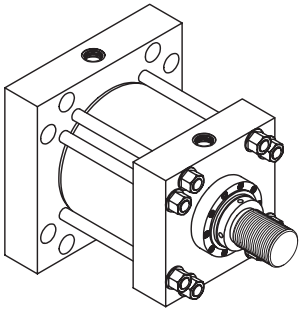

**Side Lug Mount
10"-14" Bore only
(NFPA Style MS2)**

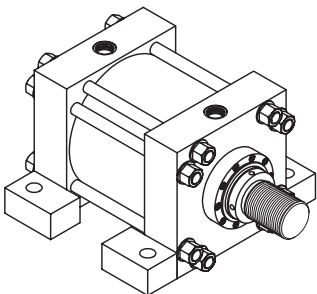

Note: Stroke lengths on lug mounted cylinders should not be shorter than the cylinder bore diameter. Consult factory for recommendations on shorter stroke lengths. See Engineering Section for further recommendations on side lug mountings.

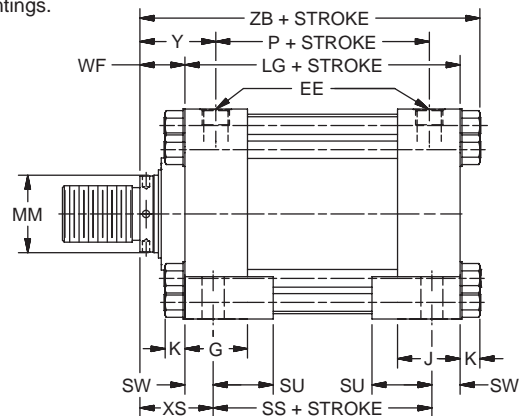
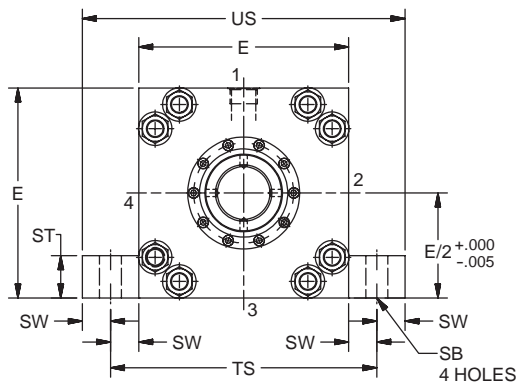

Rod End Dimensions — see table 2

Thread Style 2
(NFPA Style SM)
Small Male

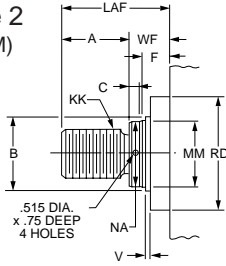

If rod end is not specified, Style 2 will be furnished.

Thread Style 3
(NFPA Style SF)
Short Female

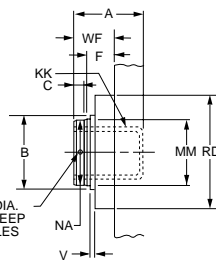

Use Style 3 for applications where female rod ends are required.

Special Thread Style 0

Special thread, extension, rod eye, blank, etc., are also available.

To order, specify "Style 0" and give desired dimensions for KK, A and LAF or WF. If otherwise special, furnish dimensional sketch.

Style 3 stroke restrictions may apply. See Style 3 Minimum Stroke page for details.

Table 1—Envelope and Mounting Dimensions

Bore	E	EB	EE* NPTF	EE† S.A.E. FLANGE PORT	EE** S.A.E. STRAIGHT THREAD	EX	FB	G	J	K	R	RE	SB	ST	SU	SW	TE	TF	TS	UF	US	Add Stroke		
																						LG	P	SS
10	12 ⁵ / ₈	1 ⁵ / ₁₆	2	2	24	16 ⁵ / ₈	1 ¹³ / ₁₆	3 ¹¹ / ₁₆	3 ¹¹ / ₁₆	1 ⁹ / ₃₂	9.62	9.89	1 ⁹ / ₁₆	2 ¹ / ₄	3 ¹ / ₂	1 ⁵ / ₈	14.13	15 ⁷ / ₈	15 ⁷ / ₈	19	19 ¹ / ₈	12 ¹ / ₈	8 ¹ / ₂	8 ⁷ / ₈
12	14 ⁷ / ₈	1 ⁹ / ₁₆	2 ¹ / ₂	2 ¹ / ₂	24	19 ³ / ₄	2 ¹ / ₁₆	4 ⁷ / ₁₆	4 ⁷ / ₁₆	1 ¹³ / ₃₂	11.45	11.75	1 ⁹ / ₁₆	3	4 ¹ / ₄	2	16.79	18 ¹ / ₂	18 ⁷ / ₈	22	22 ⁷ / ₈	14 ¹ / ₂	10 ¹ / ₈	10 ¹ / ₂
14	17 ¹ / ₈	1 ¹³ / ₁₆	2 ¹ / ₂	2 ¹ / ₂	24	21 ³ / ₄	2 ⁵ / ₁₆	4 ⁷ / ₈	4 ⁷ / ₈	1 ¹³ / ₃₂	13.26	12.90	2 ⁵ / ₁₆	4	4 ³ / ₄	2 ¹ / ₄	18.43	21	21 ⁵ / ₈	25	26 ¹ / ₈	15 ⁵ / ₈	10 ⁷ / ₈	11 ¹ / ₈

Table 1A—Envelope and Mounting Dimensions

Bore	E	EB	EE (SAE)	EE (FLANGE)	EJ	EX	FB	G	J	K	R	RA	RE	TE	TF	UF	Add Stroke		
																	LG	P	SS
16	19	1 ¹³ / ₁₆	24	3	20	24 ¹ / ₂	1 ¹³ / ₁₆	5 ⁷ / ₈	5 ⁷ / ₈	1 ²⁹ / ₃₂	15 ¹ / ₂	8	15.28	21.03	21	24 ¹ / ₂	18 ¹ / ₈	12 ¹ / ₈	
18	22	2 ¹ / ₁₆	24	3	23	26 ¹ / ₂	2 ¹ / ₁₆	6 ⁷ / ₈	6 ⁷ / ₈	1 ²⁹ / ₃₂	18	7 ¹ / ₄	16.45	22.65	24 ¹ / ₄	28 ¹ / ₄	21 ¹ / ₈	15 ¹ / ₈	
20	24	2 ¹ / ₁₆	24	3	25	29	2 ¹ / ₁₆	7 ⁷ / ₈	7 ⁷ / ₈	1 ²⁹ / ₃₂	20	8	18.07	24.87	26 ¹ / ₂	30 ¹ / ₂	23 ⁵ / ₈	17 ⁵ / ₈	

* NPTF ports are available at no extra charge.

▲ Optional SAE flange ports may be specified – flange to be supplied by customer. See Table 4 for flange port pattern dimensions.

** SAE straight thread ports are standard and are indicated by port number.

Table 2—Rod Dimensions

Bore	Rod Dia. MM	Thread KK	Rod Extensions and Pilot Dimensions									Add Stroke				
			A	+0.005 -0.005 B	C	F	LAF	NA	RD	V	WF	Y	XS	XF	ZB	
10	4 ¹ / ₂	3 ¹ / ₄ -12	4 ¹ / ₂	5.249	1	1 ¹⁵ / ₁₆	7 ⁷ / ₁₆	4 ³ / ₈	8 ¹ / ₄	8 ¹ / ₄	1 ¹ / ₄	2 ¹⁵ / ₁₆	4 ³ / ₄	4 ⁹ / ₁₆	15 ¹ / ₁₆	16 ¹ / ₃₂
	7	5-12	7	7.999	1	1 ¹⁵ / ₁₆	10 ¹ / ₂	6 ⁷ / ₈	10 ¹ / ₂	3 ³ / ₈	3 ¹ / ₂	5 ⁵ / ₁₆	5 ¹ / ₈	15 ⁵ / ₈	16 ²⁹ / ₃₂	
	5	3 ¹ / ₂ -12	5	5.749	1	1 ¹⁵ / ₁₆	8 ³ / ₁₆	4 ⁷ / ₈	8 ⁷ / ₈	1 ¹ / ₄	3 ³ / ₁₆	5	4 ¹³ / ₁₆	15 ⁵ / ₁₆	16 ¹⁹ / ₃₂	
12	5 ¹ / ₂	4-12	5 ¹ / ₂	6.249	1	1 ¹⁵ / ₁₆	8 ¹¹ / ₁₆	5 ³ / ₈	9 ³ / ₈	1 ¹ / ₄	3 ³ / ₁₆	5	4 ¹³ / ₁₆	15 ⁵ / ₁₆	16 ¹⁹ / ₃₂	
	8	5 ³ / ₄ -12	8	8.999	1	1 ¹⁵ / ₁₆	12	7 ⁷ / ₈	12 ¹ / ₂	3 ³ / ₈	4	6 ³ / ₁₆	6	18 ¹ / ₂	19 ²⁹ / ₃₂	
	7	5-12	7	7.999	1	1 ¹⁵ / ₁₆	10 ¹ / ₂	6 ⁷ / ₈	10 ¹ / ₂	3 ³ / ₈	3 ¹ / ₂	5 ¹¹ / ₁₆	5 ¹ / ₂	18	19 ¹³ / ₃₂	
14	7	5-12	7	7.999	1	1 ¹⁵ / ₁₆	10 ¹ / ₂	6 ⁷ / ₈	10 ¹ / ₂	3 ³ / ₈	3 ¹ / ₂	5 ⁷ / ₈	5 ³ / ₄	19 ¹ / ₈	20 ¹⁷ / ₃₂	
	10	7 ¹ / ₄ -12	10	10.999	1	1 ¹⁵ / ₁₆	14 ¹ / ₂	9 ⁷ / ₈	14 ¹ / ₂	3 ³ / ₈	4 ¹ / ₂	6 ⁷ / ₈	6 ³ / ₄	20 ¹ / ₈	21 ¹⁷ / ₃₂	
	8	5 ³ / ₄ -12	8	8.999	1	1 ¹⁵ / ₁₆	12	7 ⁷ / ₈	12 ¹ / ₂	3 ³ / ₈	4	6 ³ / ₈	6 ¹ / ₄	19 ⁹ / ₈	21 ¹ / ₃₂	
16	8	5 ³ / ₄ -12	8	8.999	1	1 ¹⁵ / ₁₆	12	7 ⁷ / ₈	12 ¹ / ₂	3 ³ / ₈	4	7	*	22 ³ / ₈	*	
	9	6 ¹ / ₂ -12	9	9.999	1	1 ¹⁵ / ₁₆	13 ¹ / ₄	8 ⁷ / ₈	13 ¹ / ₂	3 ³ / ₈	4 ¹ / ₄	7 ¹ / ₄	*	22 ³ / ₈	*	
	10	7 ¹ / ₄ -12	10	10.999	1	1 ¹⁵ / ₁₆	14 ¹ / ₂	9 ⁷ / ₈	14 ¹ / ₂	3 ³ / ₈	4 ¹ / ₂	7 ¹ / ₂	*	22 ⁵ / ₈	*	
18	9	6 ¹ / ₂ -12	9	9.999	1	1 ¹⁵ / ₁₆	13 ¹ / ₄	8 ⁷ / ₈	13 ¹ / ₂	3 ³ / ₈	4 ¹ / ₄	7 ¹ / ₄	*	25 ³ / ₈	*	
	10	7 ¹ / ₄ -12	10	10.999	1	1 ¹⁵ / ₁₆	14 ¹ / ₂	9 ⁷ / ₈	14 ¹ / ₂	3 ³ / ₈	4 ¹ / ₂	7 ¹ / ₂	*	25 ⁵ / ₈	*	
20	10	7 ¹ / ₄ -12	10	10.999	1	1 ¹⁵ / ₁₆	14 ¹ / ₂	9 ⁷ / ₈	14 ¹ / ₂	3 ³ / ₈	4 ¹ / ₂	7 ¹ / ₂	*	28 ¹ / ₈	*	

*Consult Factory

Table 4—Optional SAE Flange Port Pattern

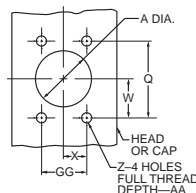

Nom. Flange Size	S.A.E. Flange Dash Size	A	Q	GG	W	X	Z-THD UNC-2B	AA Min.
1 ¹ / ₂	- 24	1.50	2.750	1.406	1.38	0.70	1/2-13	1.06
2	- 32	2.00	3.062	1.688	1.53	0.84	1/2-13	1.06
2 ¹ / ₂	- 40	2.50	3.500	2.000	1.75	1.00	1/2-13	1.19
3	- 48	3.00	4.188	2.438	2.09	1.22	5/8-11	1.19

Table 5—Tie Rod Information

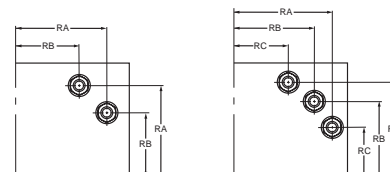

Bore	10	12	14	16	18	20
Tie Rod Thread	1 ¹ / ₈ -12	1 ¹ / ₄ -12	1 ¹ / ₄ -12	*	*	*
RA	5.291	6.270	7.485	*	*	*
RB	3.775	4.555	6.143	*	*	*
RC	—	—	4.409	*	*	*

*Consult factory for dimensions

B
PL-2
PH-2
PH-3
PHX
SHM
CHE/CHD

Mountings – Large Bore Sizes

Cap Fixed Clevis Mount
(NFA Style MP1)

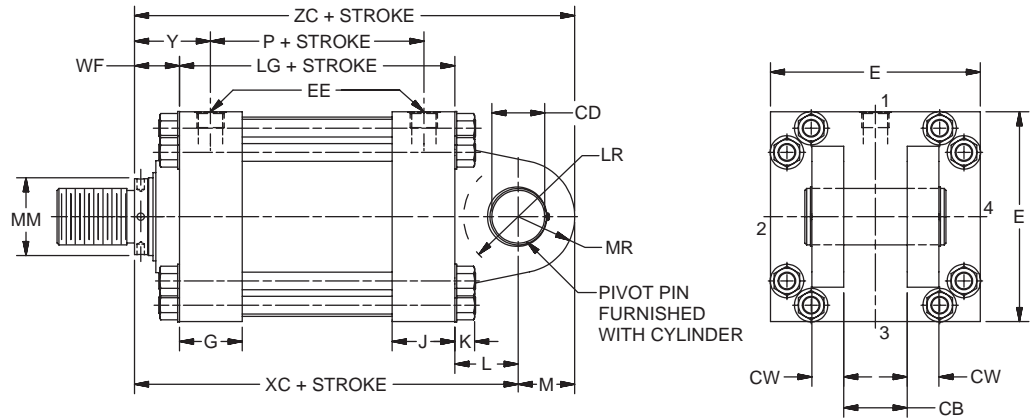
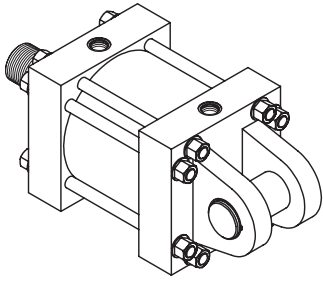

Head Trunnion Mount
10"-14" Bore only
(NFA Style MT1)

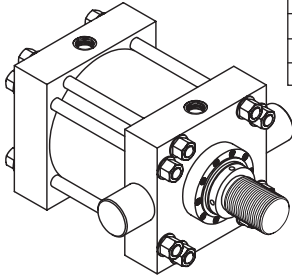

Maximum Pressure Rating - PSI

Bore	PSI
10	2800
12	2350
14	2200

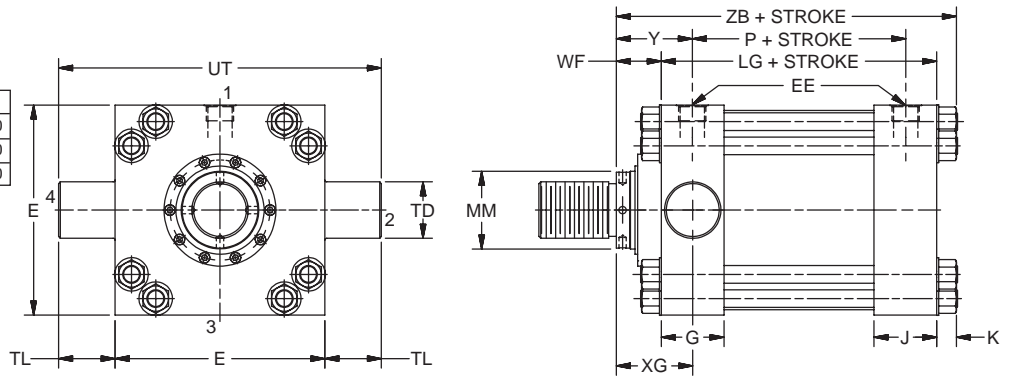

Cap Trunnion Mount
10"-14" Bore only
(NFA Style MT2)

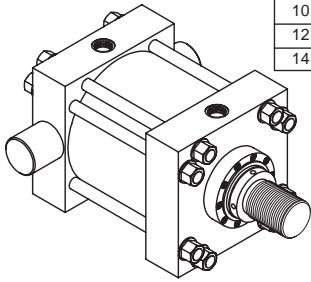

Maximum Pressure Rating - PSI

Bore	PSI
10	2800
12	2350
14	2200

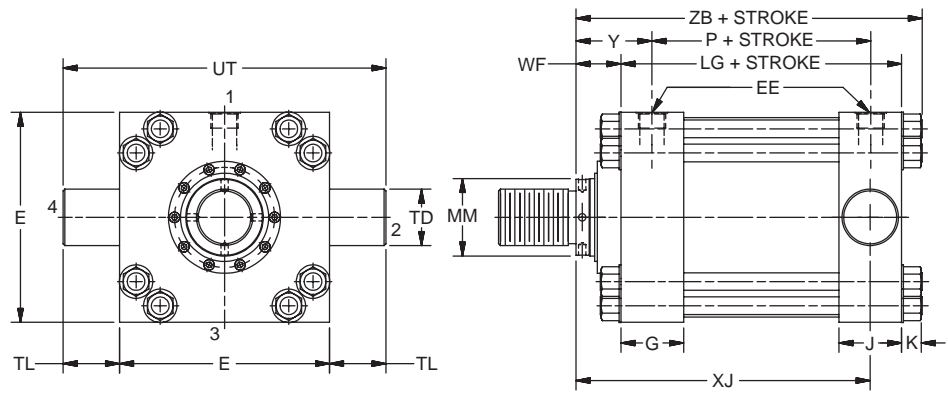

Intermediate Fixed Trunnion Mount
10"-14" Bore only
(NFA Style MT4)

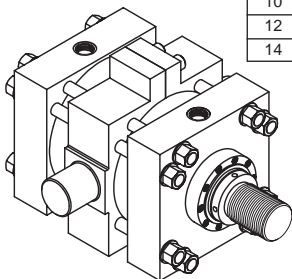

Maximum Pressure Rating - PSI

Bore	PSI
10	2800
12	2350
14	2200

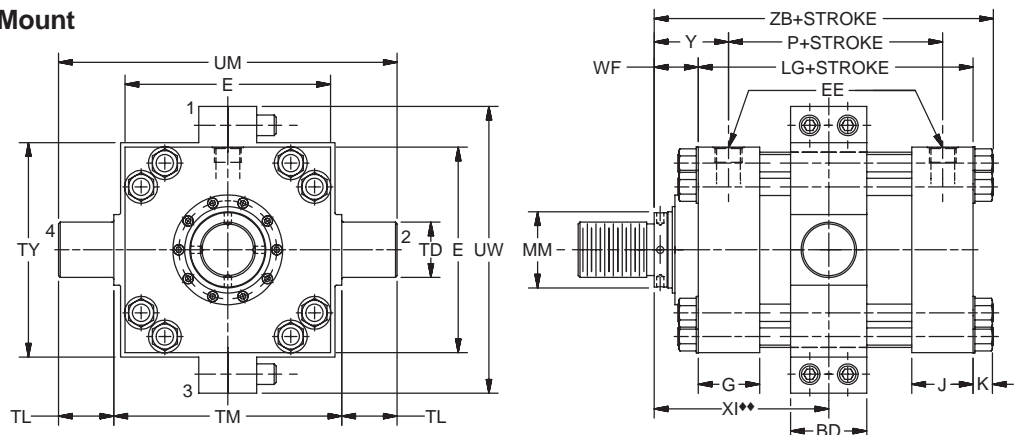

♦♦ Dimension XI to be specified by customer.

Mountings – Large Bore Sizes

Rod End Dimensions — see table 2

Thread Style 2
(NFPA Style SM)
Small Male

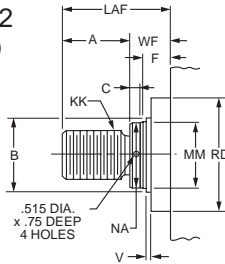

If rod end is not specified, Style 2 will be furnished.

Thread Style 3
(NFPA Style SF)
Short Female

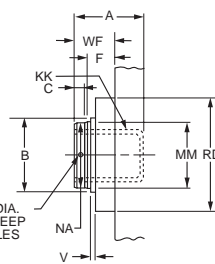

Use Style 3 for applications where female rod ends are required.

Special Thread Style 0

Special thread, extension, rod eye, blank, etc., are also available.

To order, specify "Style 0" and give desired dimensions for KK, A and LAF or WF. If otherwise special, furnish dimensional sketch.

Style 3 stroke restrictions may apply. See Style 3 Minimum Stroke page for details.

Table 1—Envelope and Mounting Dimensions

Bore	BD	CB	+0.001 -0.003 CD	CW	E	EE* NPTF	EE† S.A.E. FLANGE PORT	EE** S.A.E. STRAIGHT THREAD	G	J	K	L	LR	M	MR	+0.000 -0.001 TD	TL	TM	TY	UM	UT	UW	LG	P	Add Stroke
10	4 1/2	4	3.500	2	12 5/8	2	2	24	3 11/16	3 11/16	1 9/32	4	3 3/8	3 1/2	3 1/2	3.500	3 1/2	14	13	21	19 5/8	17 1/2	12 1/8	8 1/2	
12	5 1/2	4 1/2	4.000	2 1/4	14 7/8	2 1/2	2 1/2	24	4 7/16	4 7/16	1 13/32	4 1/2	3 7/8	4	4	4.000	4	16 1/2	15 1/2	24 1/2	22 7/8	20 3/4	14 1/2	10 1/8	
14	5 1/2	6	5.000	3	17 1/8	2 1/2	2 1/2	24	4 7/8	4 7/8	1 13/32	5 3/4	4 3/16	5	5	4.500	4 1/2	19 1/2	19 1/4	28 1/2	26 1/8	24 3/4	15 5/8	10 7/8	

Table 1A—Envelope and Mounting Dimensions (Style MP1 only)

Bore	E	EE (SAE)	EE (FLANGE)	CB	CD	CW	G	J	K	L	LR	M	MD	MR	Add Stroke	
															LG	P
16	19	24	3	7	6	3 1/2	5 7/8	5 7/8	1 29/32	7	6 1/4	6	16	6	18 1/8	12 1/8
18	22	24	3	8	6 1/2	4	6 7/8	6 7/8	1 29/32	7 5/8	6 3/4	6 1/2	18	6 1/2	21 1/8	15 1/8
20	24	24	3	9	7 1/2	4 1/2	7 7/8	7 7/8	1 29/32	8 3/4	7 3/4	7 1/2	20	7 1/2	23 5/8	17 5/8

* NPTF ports are available at no extra charge.

† Optional SAE flange ports may be specified – flange to be supplied by customer. See Table 4 for flange port pattern dimensions.

** SAE straight thread ports are standard and are indicated by port number.

Table 2—Rod Dimensions

Bore	Rod Dia. MM	Thread KK	Rod Extensions and Pilot Dimensions									Add Stroke						
			A	+0.000 -0.005 B	C	F	LAF	NA	RD	V	WF	XG	Min. XI*	Y	XC	XJ	ZB	ZC
10	4 1/2	3 1/4-12	4 1/2	5.249	1	1 15/16	7 7/16	4 3/8	8 1/4	1/4	2 15/16	4 3/4	9 1/16	4 3/4	19 1/16	13 3/8	16 11/32	22 9/16
	5	5-12	7	7.999	1	1 15/16	10 1/2	6 7/8	10 1/2	3/8	3 1/2	5 5/16	9 5/8	5 5/16	19 5/8	13 15/16	16 29/32	23 1/8
	5 1/2	4-12	5 1/2	6.249	1	1 15/16	8 3/16	4 7/8	8 7/8	1/4	3 3/16	5	9 5/16	5	19 5/16	13 5/8	16 19/32	22 13/16
12	5 1/2	4-12	5 1/2	6.249	1	1 15/16	8 11/16	5 3/8	9 3/8	1/4	3 3/16	5 3/8	10 5/8	5 3/8	22 3/16	15 1/2	19 3/32	26 3/16
	8	5 3/4-12	8	8.999	1	1 15/16	12	7 7/8	12 1/2	3/8	4	6 3/16	11 1/2	6 3/16	23	16 5/16	19 29/32	27
14	7	5-12	7	7.999	1	1 15/16	10 1/2	6 7/8	10 1/2	3/8	3 1/2	5 11/16	10 5/16	5 11/16	22 1/2	15 13/16	19 13/32	26 1/2
	10	7 1/4-12	10	10.999	1	1 15/16	14 1/2	9 7/8	14 1/2	3/8	4 1/2	6 15/16	12 7/16	6 7/8	24 7/8	16 11/16	20 17/32	29 7/8
	8	5 3/4-12	8	8.999	1	1 15/16	12	7 7/8	12 1/2	3/8	4	6 7/16	11 15/16	6 3/8	25 3/8	17 3/16	21 1/32	30 3/8
16	8	5 3/4-12	8	8.999	1	1 15/16	12	7 7/8	12 1/2	3/8	4	**	**	7	29 1/8	**	**	35 1/8
	9	6 1/2-12	9	9.999	1	1 15/16	13 1/4	8 7/8	13 1/2	3/8	4 1/4	**	**	7 1/4	29 3/8	**	**	35 3/8
18	10	7 1/4-12	10	10.999	1	1 15/16	14 1/2	9 7/8	14 1/2	3/8	4 1/2	**	**	7 1/2	29 5/8	**	**	35 5/8
	9	6 1/2-12	9	9.999	1	1 15/16	13 1/4	8 7/8	13 1/2	3/8	4 1/4	**	**	7 1/4	33	**	**	39 1/2
20	10	7 1/4-12	10	10.999	1	1 15/16	14 1/2	9 7/8	14 1/2	3/8	4 1/2	**	**	7 1/2	36 7/8	**	**	44 3/8

* Dimension XI to be specified by customer. **Consult Factory.

Table 4—Optional SAE Flange Port Pattern

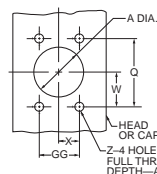

Nom. Flange Size	S.A.E. Flange Dash Size	A	Q	GG	W	X	Z-THD UNC-2B	AA Min.
1 1/2	- 24	1.50	2.750	1.406	1.38	0.70	1/2-13	1.06
2	- 32	2.00	3.062	1.688	1.53	0.84	1/2-13	1.06
2 1/2	- 40	2.50	3.500	2.000	1.75	1.00	1/2-13	1.19
3	- 48	3.00	4.188	2.438	2.09	1.22	5/8-11	1.19

Table 5—Tie Rod Information

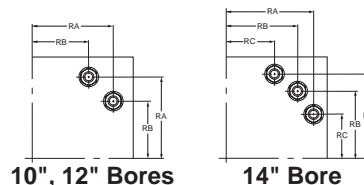

Bore	10	12	14	16	18	20
Tie Rod Thread	1 1/8-12	1 1/4-12	1 1/4-12	*	*	*
RA	5.291	6.270	7.485	*	*	*
RB	3.775	4.555	6.143	*	*	*
RC	—	—	4.409	*	*	*

*Consult factory for dimensions

B
PL-2
PH-2
PH-3
PHX
SHM
CHE/CHD

How to Use Double Rod Cylinder Dimensioned Drawings

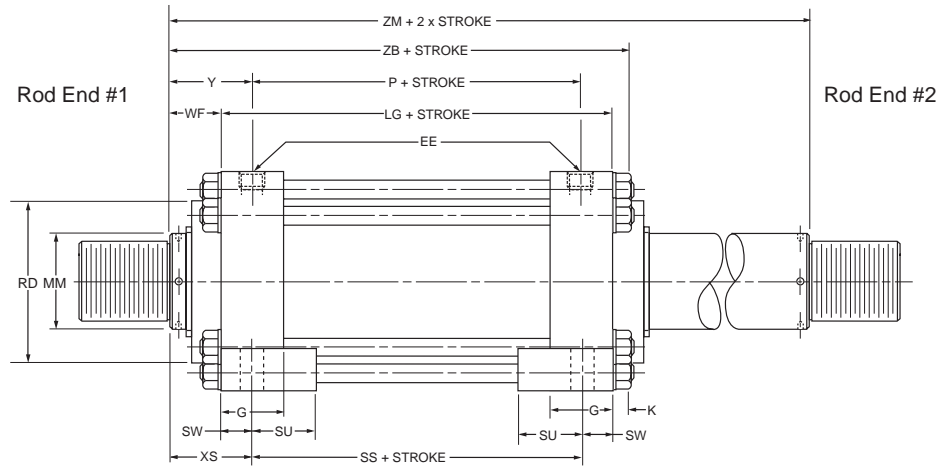
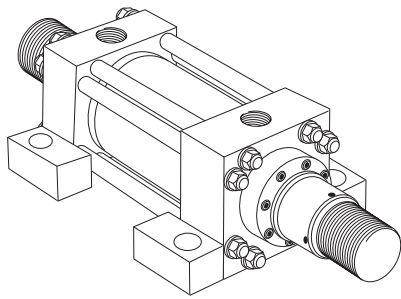

Mounting Styles for Single Rod Models	Mounting Styles for Corresponding Double Rod Models*	Dimension Shown on This Page Supplement Dimensions on Pages Listed Below
MX0	MDX0	110, 111
MX3	MDX3	110, 111
MX1	MDX1	110, 111
ME5	MDE5	112, 113
MF5	MDF5	112, 113
MS2	MDS2	114, 115
MT1	MDT1	116, 117
MT4‡	MDT4	116, 117

* If only one end of these Double Rod Cylinders is to be cushioned, be sure to specify clearly which end this will be.

‡ Specify XI dimension from rod end #1.

To obtain dimensioning information on a double rod cylinder, first select the desired mounting style and refer to the corresponding single rod cylinder model shown on the preceding pages. (See table at left.) After you have determined all necessary dimensions from that drawing, turn back to this page and supplement those dimensions with additional ones from the drawing above and table at right. These added dimensions differ from, or are in addition to, those shown on the preceding pages and provide the additional information needed to completely dimension a double rod cylinder model.

On a double rod cylinder where the two rod ends are different, be sure to clearly state which rod end is to be assembled at which end. Port position 1 is standard. If other than standard, specify pos. 2, 3 or 4 when viewed from rod end #1 only. See port position information in Section C.

Bore	Rod Dia.	Add 2X Stroke ZM
10	4 1/2	18
	7	19 1/8
	5	18 1/2
12	5 1/2	18 1/2
	8	20 7/8
	7	21 1/2
14	7	22 5/8
	10	24 5/8
	8	23 5/8
16	8	26 1/8
	9	26 5/8
	10	27 1/8
18	9	29 5/8
	10	30 1/8
20	10	32 5/8

Mounting Recommendations and Other Mountings

In addition to the standard mountings dimensioned on the preceding pages, the following information covers mounting ideas that may prove helpful in your applications. When needed, special heads, caps, and flanges can be provided. Sketches of your requirements, together with specifications relative to the application and forces involved should be submitted.

Mounting Bolts — High tensile socket head screws are recommended for all mounting styles. Use 1/16" smaller than hole size.

Flange Mountings — Cylinders can be properly centered by measuring from piston rod diameter. After mounting, the flange may be drilled for pins or dowels to prevent shifting.

Side Lug Mountings — Caution, cylinders which do not absorb force on their centerline (Group 3) tend to sway when under load. Short stroke, non-centerline mounted cylinders can subject mounting bolts to large tension forces which when combined with shear forces can overstress standard mounting bolts. Side lug mounted cylinders should always be prevented from shifting through use of shear keys so located as to resist the major load, whether push or pull.

Trunnion Mountings — Cylinders require lubricated pillow blocks with minimum bearing clearances. Pillow blocks should be carefully aligned and rigidly mounted so the trunnions will not be subjected to bending moments. The rod end connection should also be pivoted, with the customer's pin in the piston rod knuckle parallel to the trunnions.

Clevis Mountings — Cylinders should be pivoted at both ends, with the customer's pin in the piston rod knuckle parallel to the pivot pin supplied with the clevis.

Metallic Rod Wiper

When specified, metallic rod wipers can be supplied at extra cost, instead of the standard synthetic rubber wiperseal. Recommended in applications where atmospheric particles or splashing tend to cling to the extended piston rod and otherwise damage the synthetic rubber wiperseal. Installation of metallic rod wiper does not affect cylinder dimensions.

Schrader Bellows “Style 6” Piston Rod End

Rod end flange coupling for Schrader Bellows PH-3 Series Large Bore Hydraulic Cylinders

- Simplifies alignment
- Reduces assembly time
- Allows full rated hydraulic pressure in push and pull directions
- Available in 4-1/2" through 5-1/2" piston rod diameters

Style 6 Rod End

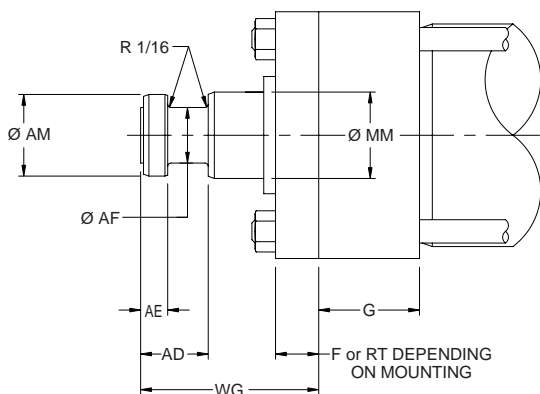

Dimensions Style 6 Rod End

MM Rod Dia.	AD	AE	AF	AM	WG
4.500	3.19	1.50	3.50	4.45	6.50
5.000	3.19	1.50	3.88	4.95	6.63
5.500	3.94	1.88	4.38	5.45	7.50
7.000	4.06	2.00	5.75	6.95	8.44
8.000	4.06	2.00	6.50	7.95	8.69
9.000	4.63	2.38	7.25	8.95	8.75
10.000	4.63	2.38	8.00	9.95	9.75

See Cylinder Catalog for F, G and RT per bore and series.

Consult Factory for availability of mounting accessories and Hardware.

How To Order

Complete Model Number and place a “6” in the Piston Rod End designator position.

Example: PHK193561x12.00

B

PL-2

PH-2

PH-3

PHX

SHM

CHE/CHD

Schrader Bellows "Style 6" Piston Rod End

Split Couplers and Weld Plates

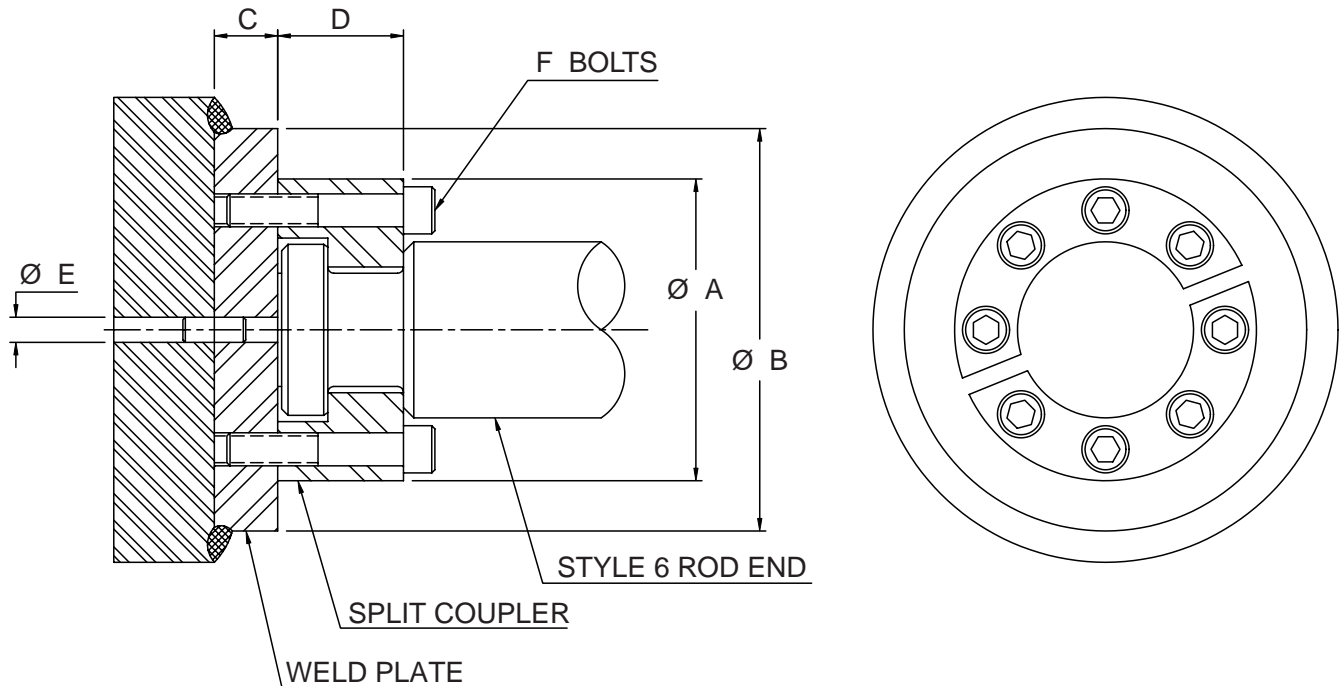

⚠ WARNING: Piston rod separation from the machine member can result in severe personal injury or even death to nearby personnel. The cylinder user must make sure the weld holding the weld plate to the machine is of sufficient quality and size to hold the intended load. The cylinder user must also make sure the bolts holding split coupler to the weld plate are of sufficient strength to hold the intended load and installed in such a way that they will not become loose during the machine's operation.

Table 1 — Part Numbers and Dimensions

Rod Ø	A Ø	B Ø	C	D	E Ø	F	Bolt Size	Bolt Circle	Split Coupler Part No.	Weld Plate Part No.
4.500	6.88	8.00	1.00	3.13	.375	12	.625-11 x 4.00 LG	5.687	147234 0450	148174 0450
5.000	7.38	8.00	1.00	3.13	.375	12	.625-11 x 4.00 LG	6.187	147234 0500	148174 0500
5.500	8.25	9.00	1.25	3.88	.375	12	.750-10 x 5.00 LG	6.875	147234 0550	148174 0550
7.000	10.38	11.00	1.75	4.00	.500	12	1.00-8 x 5.50 LG	8.750	147234 0700	148174 0700
8.000	11.38	12.00	2.00	4.00	.500	16	1.00-8 x 5.50 LG	9.750	147234 0800	148174 0800
8.500	12.38	13.00	2.00	4.00	.500	16	1.00-8 x 5.50 LG	10.750	147234 0850	148174 0850
9.000	13.12	14.00	2.25	4.00	.500	12	1.25-7 x 6.00 LG	11.125	147234 0900	148174 0900
10.000	14.12	15.00	2.50	4.50	.500	16	1.25-7 x 6.50 LG	12.125	147234 1000	148174 1000

Note: Screws are not included with split coupler or weld plate.

How to Order By Model Number

PH-3 Hydraulic Cylinders can be specified by model number by using the tables shown at right.

1. TYPE

Select the Model Number Code which identifies the single or double rod end & port specification.

2. BORE & ROD DIAMETER

Select the Model Number Code which identifies the desired bore size & rod diameter combination.

3. MOUNTING & CUSHIONING

Select the Model Number Code which identifies the desired mounting style & cushioning option.

4. ROD END STYLE

Select the Model Number Code which identifies the desired rod end thread style.

5. SEAL TYPE

Complete the model number by selecting the type of seals desired. Hi-Load piston seals are standard.

6. STROKE LENGTH

It is necessary to specify the stroke length desired following the Model Number. For example: PHA100823 with 6" stroke.

THE EXAMPLE WOULD IDENTIFY:

A single rod end hydraulic cylinder with S.A.E. flange ports, 10" bore size, 4 1/2" diameter piston rod, side lug mounting, cushioned both ends, with a small male rod end thread, high load piston with Buna-N seals & a 6" stroke.

SPECIFYING THE DESIRED TRUNNION LOCATION: (Style MT4 Mounting)

For cylinders with intermediate trunnion mounting, specify the distance between the piston rod reference point & the centerline of the trunnion pin. (Dimension "X1")

OPTIONAL MOUNTING ACCESSORIES

Specify separately by part number the desired optional mounting or rod end accessories.

SPECIAL MODIFICATIONS

For special modifications other than piston rod end, use "S" in the 10th position of the model number & describe the special feature required.

Example: PHK190825S 6" Stroke

Ports to be in position # 2.

1	Model Number
Type	PH-3 Series Hydraulic
Single End with SAE Straight Thread Ports	PH
Double End with SAE Straight Thread Ports	PJ
Single End with NPTF Ports	PF
Double End with NPTF Ports	PK
Single End with SAE Flange Ports	PX
Double End with SAE Flange Ports	PY

2					
Bore Size	Rod Dia.	Model Number Code	Bore Size	Rod Dia.	Model Number Code
10"	4-1/2"	K19	16"	8"	R45
	5"	K41		9"	R47
	5-1/2"	K42		10"	R46
	7"	K43		9"	T47
12"	5-1/2"	L42	18"	10"	T46
	7"	L43		20"	10"
	8"	L45			
14"	7"	M43			
	8"	M45			
	10"	M46			

3	Mounting Style	Model Number Code				
		NFPA Style	Non-Cush.	Cush. Head	Cush. Cap	Cush. Both
	Side Lug	MS2	05	06	07	08
	Head Square	MF5	29	30	31	32
	Cap Square	MF6	33	34	35	36
	Head Rectangular	ME5	45	46	47	48
	Cap Rectangular	ME6	49	50	51	52
	Tie Rods Extended Both Ends	MX1	53	54	55	56
	Cap Tie Rods Extended	MX2	57	58	59	60
	Head Tie Rods Extended	MX3	61	62	63	64
	Head Trunnion	MT1	69	70	71	72
	Cap Trunnion	MT2	73	74	75	76
	Intermediate Fixed Trunnion	MT4	77	78	79	80
	Cap Fixed Clevis	MP1	81	82	83	84

4	Rod End Style	Model Number Code
	Small Male	2
	Short Female	3
	Intermediate Male	4
	Rod End for Flange Coupling	6
	Special – Specify	0

5	Seal Type	Available on Bore Sizes	Model Number Code
	Buna N Seals w/Lipseal Piston		1
	Fluorocarbon Seals w/Lipseal Piston	Optional on 10" thru 14" only	2
	Buna N Seals w/Piston Rings		3
	Fluorocarbon Seals w/Piston Rings		4
	Buna N Seals w/Hi-Load Piston	10" thru 20"	5
	Fluorocarbon Seals w/Hi-Load Piston		6

6	Specify Stroke Length	6"
----------	------------------------------	-----------

Model Number Example:
PH K19 08 2 5 w/6"

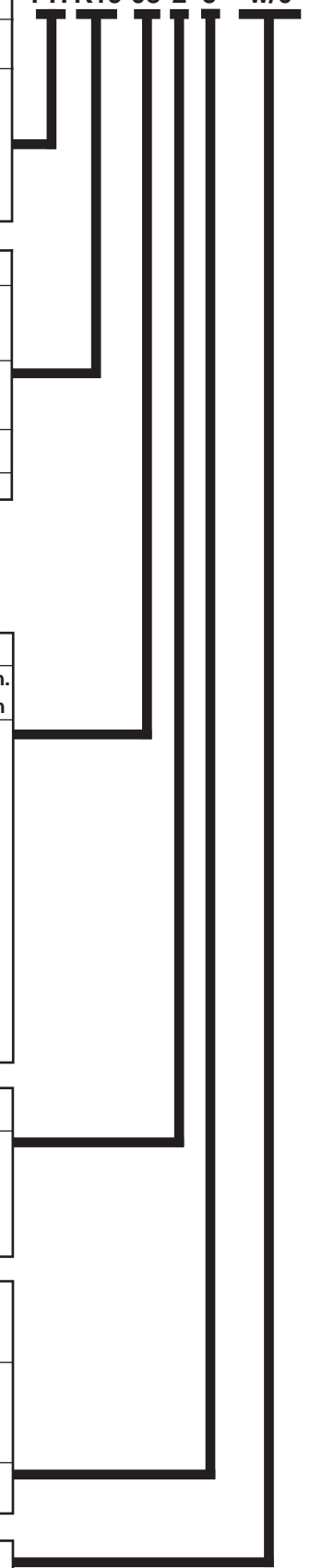

B

PL-2

PH-2

PH-3

PHX

SHM

CHE/CHD

NOTES



Contents

Features	124
Valve Footprint & Manifold Position Options	125

LDT & LRT Specifications.....	125
How to Order PHX Series Cylinders.....	126

B

PL-2

PH-2

PH-3

PHX

SHM

CHE/CHD

Schrader Bellows Series PHX Electrohydraulic Actuators

Schrader Bellows Series PHX actuators can be customized to meet your exact specifications for NFPA interchangeable hydraulic cylinders with valve manifolds, integral feedback devices, or both!

Schrader Bellows Series PHX actuators combine the rugged Schrader Bellows PH-2 Series cylinders with the following:

- Bolt-on or Integral Manifolds for direct-mounted Servo, Proportional or Industrial NFPA Hydraulic Valves. A custom steel transfer tube is provided between the valve manifold and the opposite cylinder end cap.
- Linear Displacement Transducer (LDT) or Linear Resistance Transducer (LRT) provide precise digital or analog position (or velocity) feedback.

Series PHX Linear Actuators are specifically designed to meet today's demand for readily available, low cost linear actuators. With the industry's broadest range of standard manifold and feedback options, we are ready to meet your most challenging control application.

PHX with Bolt-On Manifold

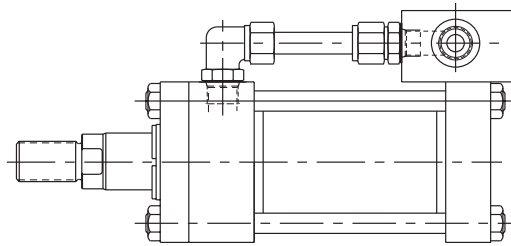

PHX with Bolt-On Manifold and LDT

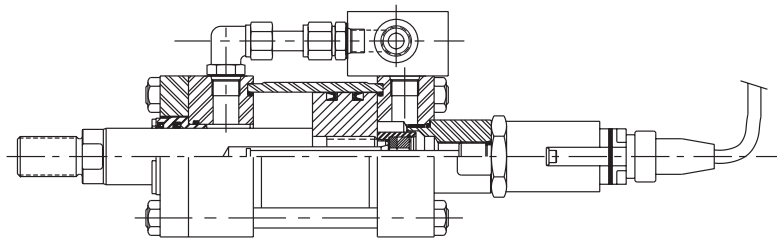

PHX with Integral Manifold

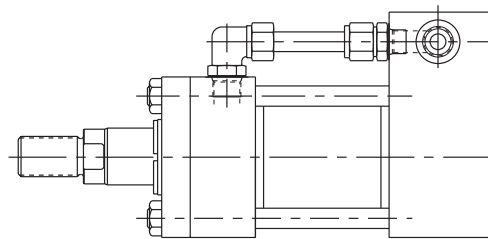

PHX with Integral Manifold and LDT

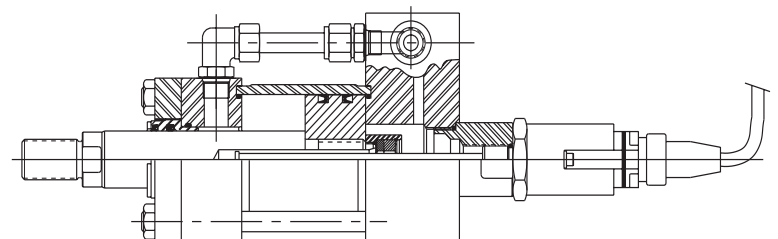

PHX with LDT Feedback Only

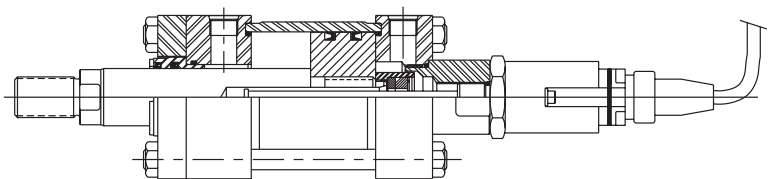

Table A – Standard Valve Footprint Options

Group	Valve Footprint Pattern	Bolt-On Manifold Available Bores	Integral Manifold Available Bores
Group A	Servo (see "Group A" at right)	2" through 8"	2" through 5"
Group D	Servo (see "Group D" at right)	3.25" through 8"	2" through 5"
Group G	NFPA D03	2" through 8"	2" through 5"
Group H	NFPA D05	2" through 8"	2" through 5"
Group J	NFPA D06	6" through 8"	not available
Group K	NFPA D07	6" through 8"	not available
Group M	NFPA D08	6" through 8"	not available

Group A servo patterns
 Parker BD15
 Atchley 215A-XXX
 Moog Series 62, 73, 760
 Pegasus M & MP
 Vickers Series SM4-20-X-X-10

Group D servo patterns
 Parker BD-30
 Atchley 240-XXX
 Moog Series 78
 Pegasus 180L & 180R
 Vickers Series SM4-40-X-X-10

(Consult factory for mounting and stroke limitations and exclusions)

Table B – Available Mounting and Manifold Position

MOUNTING STYLE	DESCRIPTION	BOLT-ON-MANIFOLD MOUNTING POSITION		INTEGRAL MANIFOLD	APPLICABLE FEEDBACK DEVICES
		CAP END ¹	HEAD END ¹	CAP END ONLY	
MX3	Head Tie Rods Extended	1,2,3,4	1,2,3,4	1	LRT and LDT†
MX2	Cap Tie Rods Extended	1,2,3,4	1,2,3,4	N/A	
MX1	Both Ends Tie Rods Extended	1,2,3,4	1,2,3,4	N/A	
MF1	Head Rectangular Flange	1,2,3,4	CF	1	LRT and LDT
MF5	Head Square Flange	1,2,3,4	CF	1	
ME5	Head Rectangular	1,2,3,4	CF	1	
MF2	Cap Rectangular Flange	CF	1,2,3,4	N/A	LRT
MF6	Cap Square Flange	CF	1,2,3,4	N/A	LRT and LDT†
ME6	Cap Rectangular	CF	1,2,3,4	N/A	
MS2	Side Lug	1	1	1	
MS4	Side Tapped	1,2&4 CF	1,2&4 CF	1	LRT and LDT††
MP1*	Cap Fixed Clevis	CF	1,2,3,4	1	LRT and LDT††
MT1	Head Trunnion	1,2,3,4	1,3	1	LRT and LDT
MT2	Cap Trunnion	1,3	1,2,3,4	N/A	
MT4	Intermediate Fixed Trunnion	1,2,3,4	1,2,3,4	1	
MPU3*	Spherical Bearing	CF	1,2,3,4	1	LRT and LDT††

Note:

* Overhang of Bolt-On-Manifold may affect mounting and application of cylinder, consult factory.

1 If cylinder has cushions, needle and check valve will be located at standard positions.

† LDT Feedback devices extend beyond the face of the cap and may interfere with cap end mounts.

†† When LDT Feedback devices are selected with cap end mounts a false stage cylinder body is required.

N/A = Not Available.

CF = Consult Factory.

LDT Specifications – Temposonics GH™

Input Voltage:

+24Vdc (+20%, -15%) standard

+9 to 23 Vdc optional

Stroke Length: 1 to 120"

Dead Zone: 2.5"

Electronics Enclosure: IP67

Vibration: Complies with IEC 68-2-6

Operating Pressure: 5000 psi

Non-Linearity: ±.02% of stroke or ±.002", whichever is greater.

Repeatability: ±.001% of stroke or ±.0001", whichever is greater

Operating Temperature: -40 to +185° F

Note: LDT comes standard with a DIN 6 style connector and 5' extension cable. If cylinder includes style A protective enclosure, LDT will be supplied with RO Integral Pigtail Cable (5' length).

Adaptor cables are available when replacing cylinders equipped with Temposonics LH™ LDT's. Contact the factory for details.

LDT Output Options – Temposonics GH™

The LDT utilizes on-board electronics contained in the sensor head to generate several absolute output options. The required output must be specified at the time of order. In applications where it is desirable to locate the output electronics in a remote location, or where the sensor head is not accessible, and optional Analog Output Module (AOM) is available. The standard outputs for each option are at right:

LDT Outputs

- Analog Outputs
 - 0 to 10 Vdc or 10 to 0 Vdc
 - 10 to +10 Vdc or +10 to -10 Vdc
 - 4 to 20 mA or 20 to 4 mA
 - 0 to 20 mA or 20 to 0 mA

- Digital Pulse Outputs
 - PWM
 - Start/Stop

Note: Velocity output or velocity and position output requires use of an AOM.

LRT Specifications

Non-Linearity – Less than 0.1% of full scale up to 48" stroke. Less than 1.0% of full scale over 48" stroke.

Repeatability – .001 inch

Input Voltage – Nominal 5-50 Vdc

Operating Temperature Range – -40°F to +160°F

Cylinder Stroke Length – Up to 120"

Electrical Connector – Brad Harrison 3-pin mini connector interface at position #4 standard.

Total Resistance – 800Ω per inch of stroke (±20%) + end resistance.

End Resistance – 800Ω

Maximum Velocity – 30 inches per second

Life Expectancy – Greater than 50 x 10⁶ cycles (Based on 1" stroke @10 ips)

Fluid Medium – Petroleum based hydraulic fluids. May not be used with water based or high water content fluids.

End Voltage Loss – (V source) x (400/stroke x 800)

Power Dissipation – supply voltage squared, divided by the total resistance.

The LRT requires a high impedance interface greater than 100K ohms. A maximum of 1 microamp should be required from the LRT.



Contents

Introduction.....	128	Double Rod Cylinders.....	138
Features, Specifications and Mountings.....	129	Accessories	139-141
Design Features and Benefits	130-131	Model Numbers	142-143
Mounting Styles	132	Parts I.D. and Seal Kits	Sec. C, pgs. 45-46
Piston Rod End Data / Thread Styles.....	133	Application Engineering Data	Sec. C, pgs. 91-102
Mounting Information.....	134-137		

B

PL-2

PH-2

PH-3

PHX

SHM

CHE/CHD

SHM Series Metric Hydraulic Cylinders

As a world leader in the design and manufacture of pneumatic and hydraulic cylinders, Schrader Bellows Industrial Cylinder Division offers the SHM Series *metric* hydraulic cylinder. Schrader Bellows' SHM Series cylinders are designed to meet the requirements of ISO 6020/2 (1991), 160 Bar Compact Series. SHM Series cylinders may be used for working pressures up to 210 Bar.

Schrader Bellows SHM Series cylinders are the true *world standard*, available all over the globe from worldwide manufacturing facilities.



Introduction

The SHM Series cylinders described in this catalog are Compact Series cylinders to ISO 6020/2 rated for use at working pressures up to 210 bar. They have been designed to satisfy the requirements of a wide range of industries in which cylinders to ISO standards are specified.

In addition to the standard cylinders featured in this catalog, SHM cylinders can be designed to suit customer requirements. Our engineers will be pleased to advise on unique designs to suit specific applications.

SHM Series Standard Features and Specifications

- ISO 6020/2 mounting interchangeable
- 12 standard mounting styles
- Up to 3 rod sizes per bore
- Wide range of mounting accessories
- Up to 3 male and 3 female rod end threads per bore
- Bore sizes – 25mm to 200mm
- Strokes – available in any practical stroke length
- Working pressure up to 210 bar
- Piston rods – 12mm to 140mm
- Single and Double rod designs
- Cushions available at either or both ends
- Temperature Range – -20°C to +150°C depending on seal type
- Seal types to suit a wide variety of operating environments

In line with our policy of continuing product improvement, specifications in this catalog are subject to change.

Available Mountings

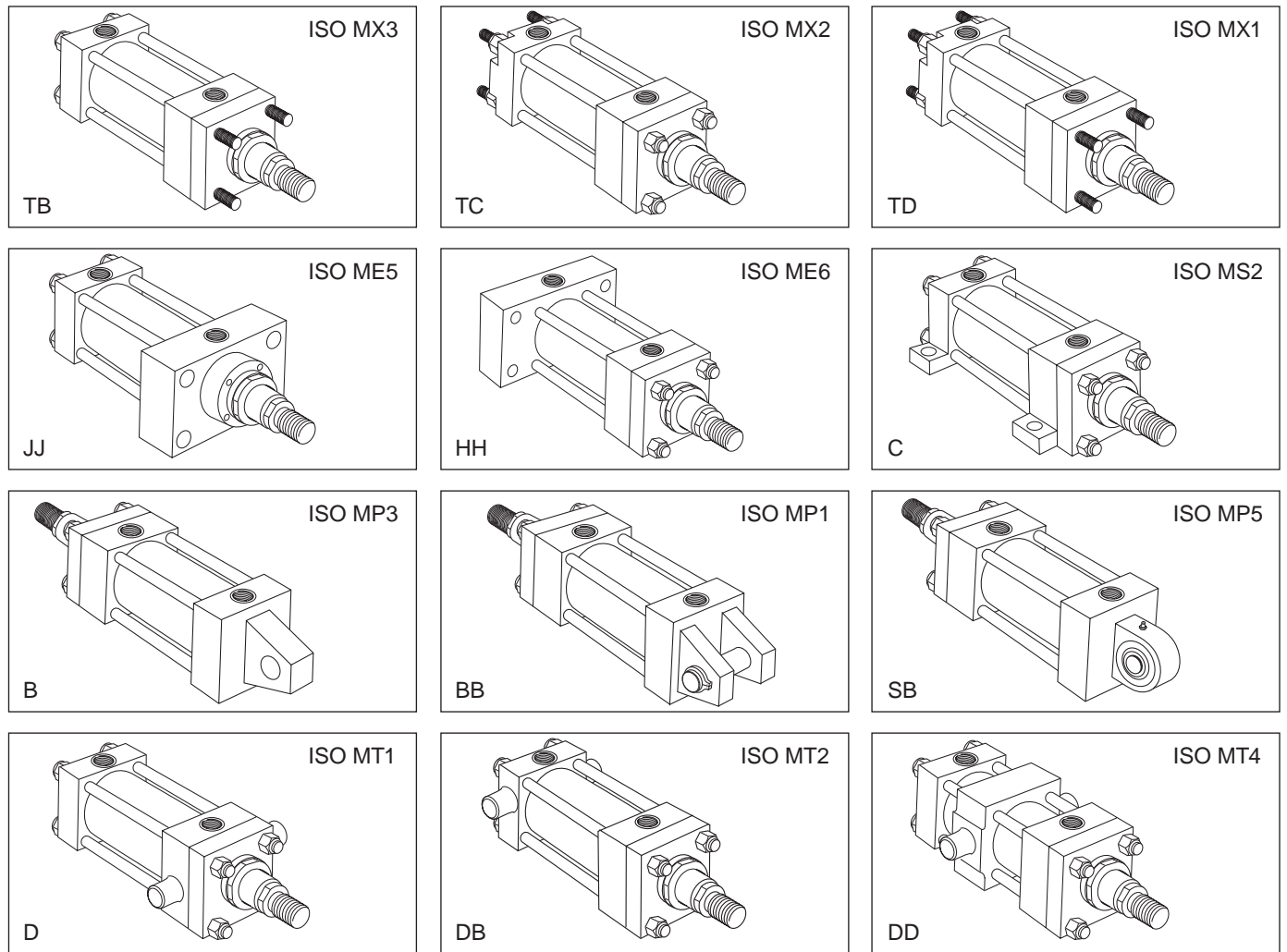

B

PL-2

PH-2

PH-3

PHX

SHM

CHE/CHD

Here is the inside story of why the SHM Series is your best choice in a metric heavy duty hydraulic cylinder...

1 Piston Rod

Gland seal life is maximized by manufacturing piston rods from precision ground, high tensile carbon steel, hard chrome plated and polished to 0.2µm max. Piston rods are induction case hardened to Rockwell C54 minimum before chrome plating, resulting in a dent-resistant surface.

2 Schrader Bellows 'Quick' Gland

Continuous lubrication, and therefore longer gland life, are provided by the long bearing surface inboard of the primary seal. The gland, complete with rod seals, can easily be removed without dismantling the cylinder and without special tools, so servicing is quicker – and therefore more economical.

3 Rod Seals

The Tuff Seal primary seal has a series of sealing edges which take over successively as pressure increases, providing efficient sealing under all operating conditions. On the return stroke the serrations act as a check valve, allowing the oil adhering to the rod to pass back into the cylinder.

The double lip wiperseal acts as a secondary seal, trapping excess lubricating film in the chamber between the wiper and lip seals. Its outer lip prevents the ingress of dirt into the cylinder, extending the life of gland and seals.

The Tuff Seal is manufactured from an enhanced polyurethane, giving efficient retention of pressurized fluid and long service life.

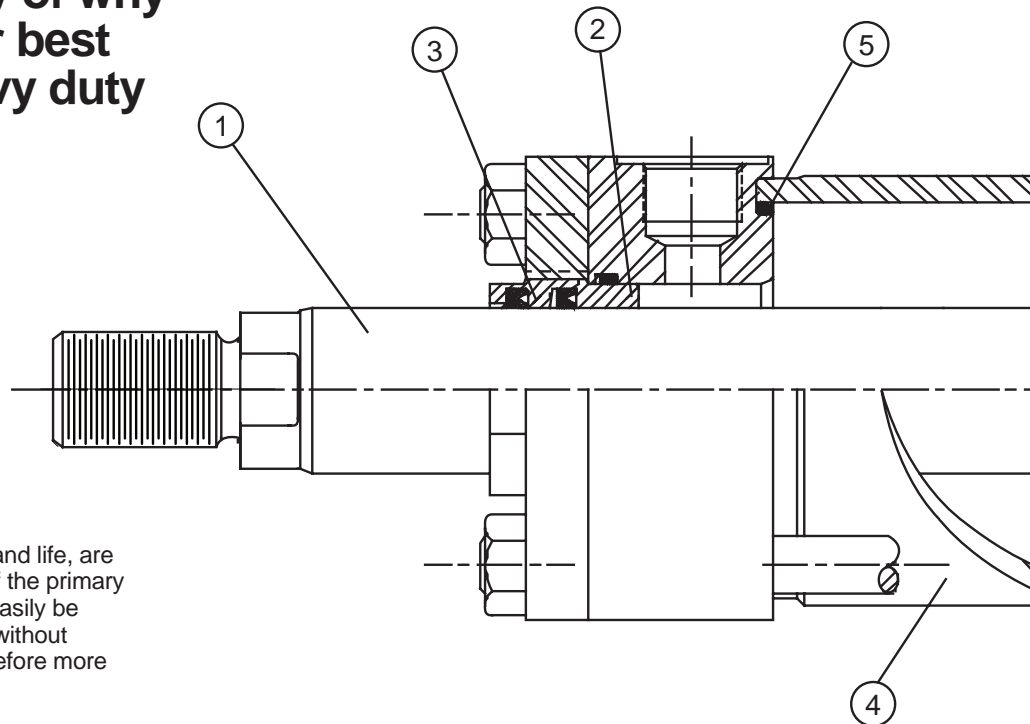

4 Cylinder Body

Strict quality control standards and precision manufacture ensure that all tubes meet rigid standards of straightness, roundness and surface finish. The steel tubing is surface finished to minimize internal friction and prolong seal life.

5 Cylinder Body Seals

To make sure that the cylinder body remains leak-free, even under pressure shock conditions, Schrader Bellows utilizes pressure-energized body seals.

6 One-Piece Piston

Side loading is resisted by wear rings on the piston. A long thread engagement secures the piston to the piston rod and, as an added feature, pistons are secured by an anaerobic adhesive.

Optional

Air Bleeds

Available as an option at both ends, the air bleeds are recessed into the head and cap.

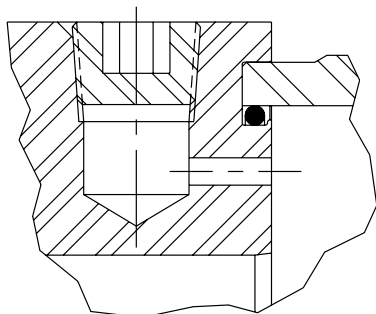

Servo Cylinders

Servo cylinders permit fine control of acceleration, velocity and position in applications where very low friction and an absence of stick-slip are required. They may be used in conjunction with integral or external transducers. Servo cylinders combine low friction piston and gland seals with specially selected tubes and rods. For low-friction applications – consult factory.

Seal Classes

To accommodate the many types of fluids and the varying temperature ranges used in industry, Schrader Bellows offers a range of rod gland, piston and body seals.

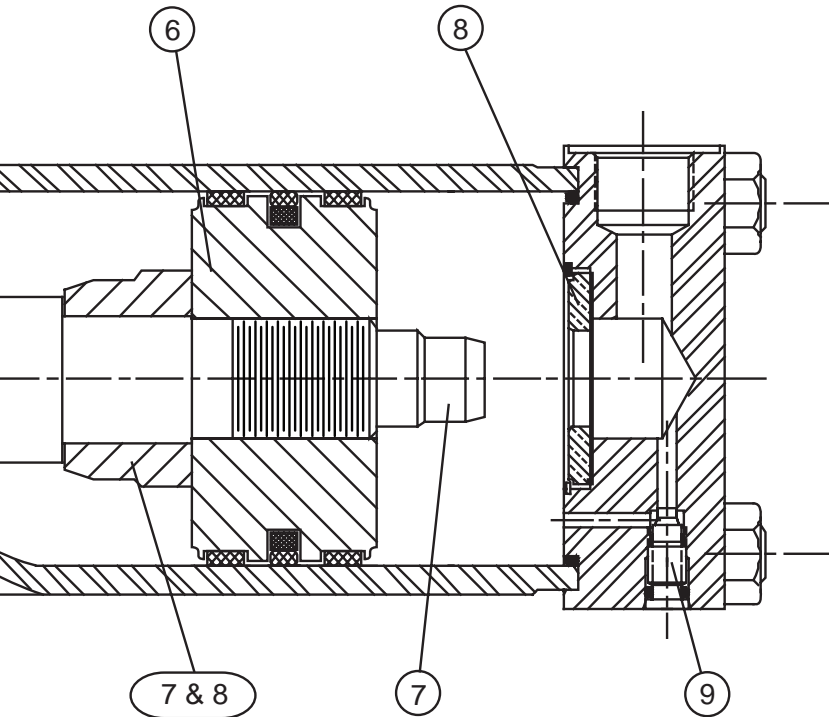

7 Cushioning

Progressive deceleration is available by using profiled cushions at the head and cap. The head end cushion is self aligning, while the polished cap end spear is an integral part of the piston rod.

8 Floating Cushion Bushings and Sleeves

Closer tolerances – and therefore more effective cushioning – are permitted by the use of a floating cushion sleeve at the head end of the cylinder, and a floating cushion bushing at the cap end. A slotted cushion sleeve on the head end, and the floating bronze cushion bushing in the cap, provide minimum fluid restriction at the start of the return stroke. This allows full pressure to be applied over the entire area of the piston, providing full power and fast cycle times.

Gland Drains

The accumulation of fluid behind the gland wiperseal of long stroke cylinders, or cylinders with constant back pressure, can be relieved by specifying the option of a gland drain. A port between the wiperseal and primary seal allows fluid to be piped back to a reservoir. By fitting a transparent tube between the port and the reservoir, fluid loss from concealed or inaccessible cylinders can be monitored to provide an early indication of the need for gland servicing.

9 Cushion Adjustment

Needle valves are provided at both ends of the cylinder for precise cushion adjustment.

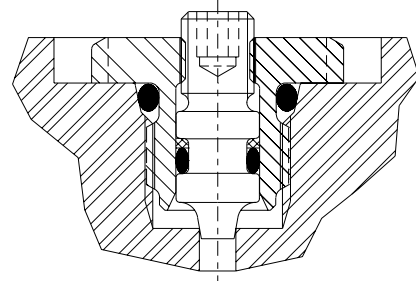

10 Piston Seals

Standard on 25mm, 32mm and 40mm bore sizes, Schrader's Lipseal™ Piston provides zero leakage under static conditions for hydraulic pressures up to 3000 psi. Seals are self-compensating to conform to variations in pressure, mechanical deflection, and wear. Back-up washers prevent extrusion.

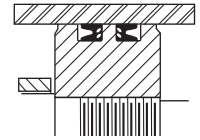

Standard on 50mm bore sizes and larger, Schrader's B style piston is a single seal design which incorporates two wear strips. This design provides smooth operation, long bearing life, and high load carrying capacity.

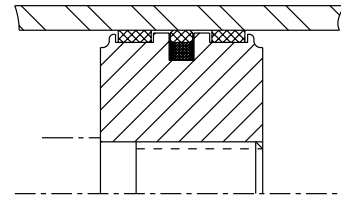

Mixed Media Piston Seals

For applications requiring different media on either side of the piston specify Mixed Media Piston Seals with a W piston code. This option is ideal when hydraulic oil is on one side of the piston and air on the opposite side; and it can be equally effective when dissimilar fluids are on either side of the piston. Superior low-friction bi-directional sealing is accomplished by combining an energized filled PTFE seal with a redundant elastomer seal.

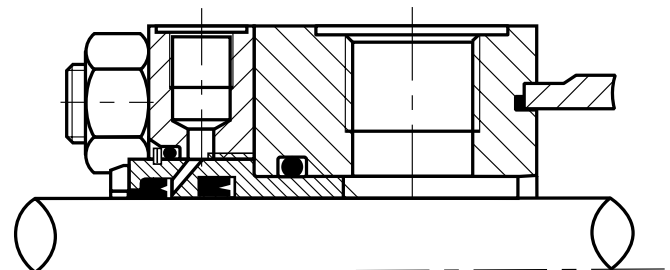

ISO Cylinder Mounting Styles

The standard range of Schrader Bellows SHM Series cylinders comprises 12 ISO mounting styles, to suit the majority of applications. General guidance for the selection of ISO cylinders is given below, with dimensional information about each mounting style shown on the following pages. Application-specific mounting information is shown in the Mounting Information section of this catalog.

Extended Tie Rods

Cylinders with TB, TC and TD mountings are suitable for straight line force transfer applications, and are particularly useful where space is limited. For compression (push) applications, cap end tie rod mountings are most appropriate; where the major load places the piston rod in tension (pull applications), head end mounting styles should be specified. Cylinders with tie rods extended at both ends may be attached to the machine member from either end, allowing the free end of the cylinder to support a bracket or switch.

Flange Mounted Cylinders

These cylinders are also suitable for use on straight line force transfer applications. Two flange mounting styles are available, offering either a head flange (JJ) or a cap flange (HH). Selection of the correct flange mounting style depends on whether the major force applied to the load will result in compression (push) or tension (pull) stresses on the piston rod. For compression-type applications, the cap mounting style is most appropriate; where the major load places the piston rod in tension, a head mounting should be specified.

Foot Mounted Cylinders

Style C, foot mounted cylinders do not absorb forces on their centerline. As a result, the application of force by the cylinder produces a moment which attempts to rotate the cylinder about its mounting bolts. It is important, therefore, that the cylinder should be firmly secured to the mounting surface and that the load should be effectively guided to avoid side loads being applied to rod gland and piston bearings. A thrust key modification may be specified to provide positive cylinder location.

Pivot Mountings

Cylinders with pivot mountings, which absorb forces on their centerlines, should be used where the machine member to be moved travels in a curved path. Pivot mountings may be used for tension (pull) or compression (push) applications. Cylinders using a fixed clevis, styles BB and B, may be used if the curved path of the piston rod travel is in a single plane; for applications where the piston rod will travel in a path on either side of the true plane of motion, a spherical bearing mounting SB is recommended.

Trunnion Mounted Cylinders

These cylinders, styles D, DB and DD, are designed to absorb force on their centerlines. They are suitable for tension (pull) or compression (push) applications, and may be used where the machine member to be moved travels in a curved path in a single plane. Trunnion pins are designed for shear loads only and should be subjected to minimum bending stresses.

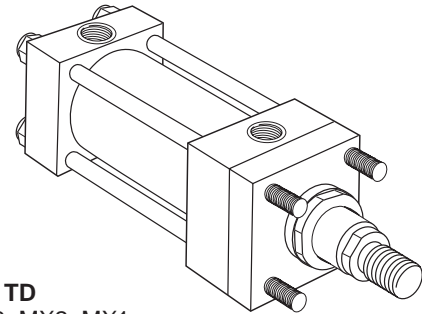

Styles TB, TC, TD
ISO Styles MX3, MX2, MX1

TB

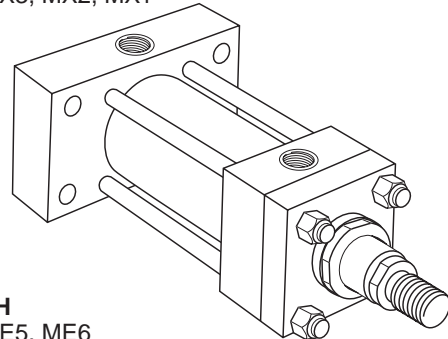

Styles JJ, HH
ISO Styles ME5, ME6

HH

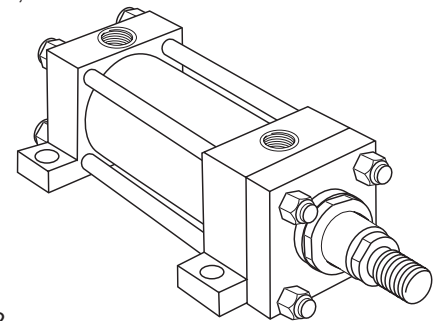

Style C
ISO Style MS2

C

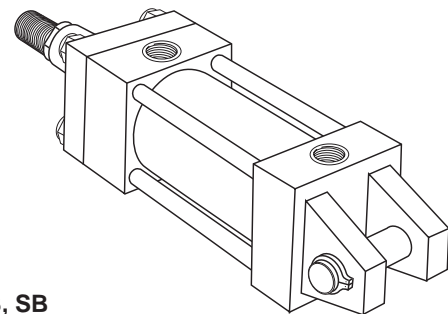

Styles B, BB, SB
ISO Styles MP3, MP1, MP5

BB

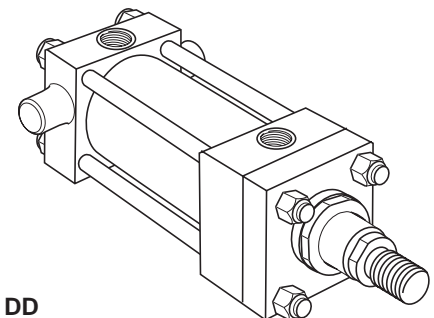

Styles D, DB, DD
ISO Styles MT1, MT2, MT4

DB

**Thread Styles 4 & 7 –
All Except JJ Mount**

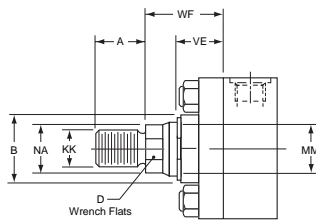

**Thread Styles 4 & 7 –
JJ Mount**

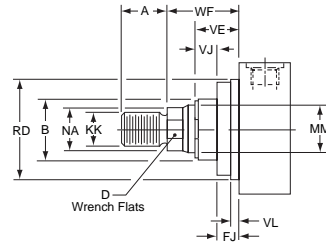

**Thread Style 9 –
All Except JJ Mount**

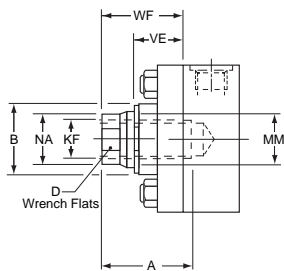

**Thread Style 9 –
JJ Mount**

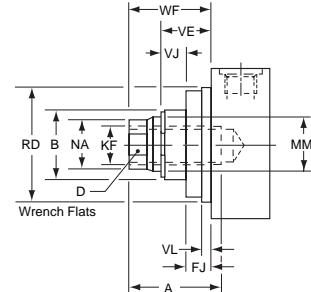

Thread Styles 4 & 7

The smallest diameter rod end thread for each bore size is designated Style 4 when supplied with a No. 1 rod. When the same rod end thread is supplied with a No. 2 or No. 3 rod, it is designated Style 7.

**Thread Style 9 –
Short Stroke Cylinders**

Style 9 (female) rod ends should not be used on 160mm or 200mm bore cylinders with a stroke of 50mm or less. Please consult the factory, with details of the application.

Thread Style 3

Non-standard piston rod ends are designated 'Style 3'. A dimensional sketch or description should accompany the order. Please specify dimensions KK or KF, A, rod stand out WF and thread type.

25 & 32mm Bore Cylinders

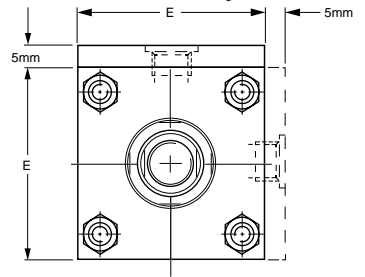

5mm extra height applies to port face at head end only.

**Gland Retainer –
160 and 200mm Bore**

On all 160mm and 200mm bore ISO mounting styles except TB and TD, the gland retainer is separately bolted to the head, as shown.

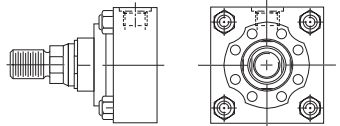

Piston Rod End Dimensions

Bore Φ	Rod No.	MM Rod Φ	Style 4		Style 7		Style 9		B f9	D	NA	VE	WF	JJ Mount Only			
			KK	A	KK	A	KF	A						VL min	RD f8	VJ	FJ
25	1	12	M10x1.25	14	-	-	M8x1	14	24	10	11	16	25	3	38	6	10
	2	18	M14x1.5	18	M10x1.25	14	M12x1.25	18	30	15	17	16					
32	1	14	M12x1.25	16	-	-	M10x1.25	16	26	12	13	22	35	3	42	12	10
	2	22	M16x1.5	22	M12x1.25	16	M16x1.5	22	34	18	21	22					
40	1	18	M14x1.5	18	-	-	M12x1.25	18	30	15	17	16	35	3	62	6	10
	2	28	M20x1.5	28	M14x1.5	18	M20x1.5	28	42	22	26	22					
50	1	22	M16x1.5	22	-	-	M16x1.5	22	34	18	21	22	41	4	74	6	16
	2	36	M27x2	36	M16x1.5	22	M27x2	36	50	30	34	25					
63	1	28	M20x1.5	28	-	-	M20x1.5	28	42	22	26	22	48	4	75	6	16
	2	45	M33x2	45	M20x1.5	28	M33x2	45	60	39	43	29					
80	1	36	M27x2	36	-	-	M27x2	36	50	30	34	25	51	4	82	5	20
	2	56	M42x2	56	M27x2	36	M42x2	56	72	48	54	29					
100	1	45	M33x2	45	-	-	M33x2	45	60	39	43	29	57	5	92	7	22
	2	70	M48x2	63	M33x2	45	M48x2	63	88	62	68	32					
125	1	56	M42x2	56	-	-	M42x2	56	72	48	54	29	57	5	125	7	22
	2	90	M64x3	85	M42x2	56	M64x3	85	108	80	88	32					
160	1	70	M48x2	63	-	-	M48x2	63	88	62	68	32	57	5	105	9	20
	2	110	M80x3	95	M48x2	63	M80x3	95	133	100	108	32					
200	1	90	M64x3	85	-	-	M64x3	85	108	80	88	32	57	5	150	10	22
	2	140	M100x3	112	M64x3	85	M100x3	112	163	128	138	32					
	3	110	M80x3	95	M64x3	85	M80x3	95	133	100	108	32					

All dimensions are in millimeters unless otherwise stated.

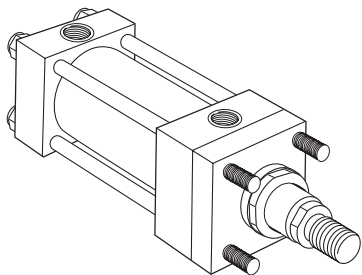

Style TB
Tie Rods Extended Head End
(ISO Style MX3)

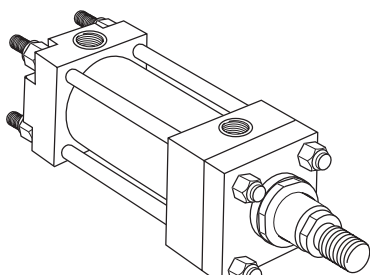
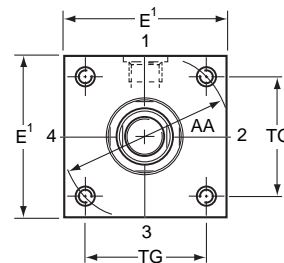
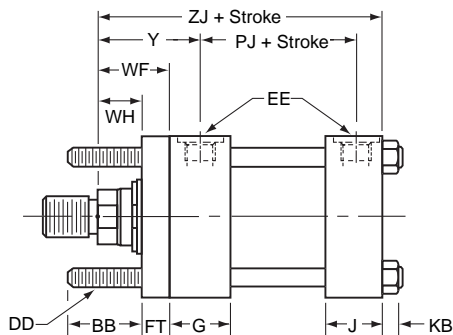

Style TC
Tie Rods Extended Cap End
(ISO Style MX2)

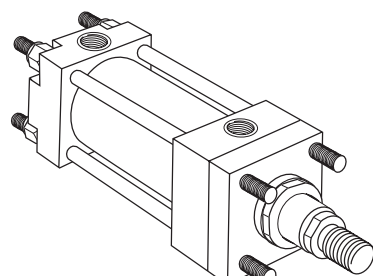
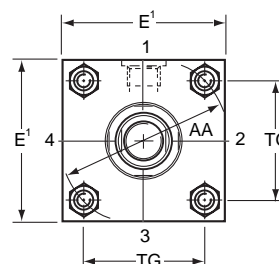
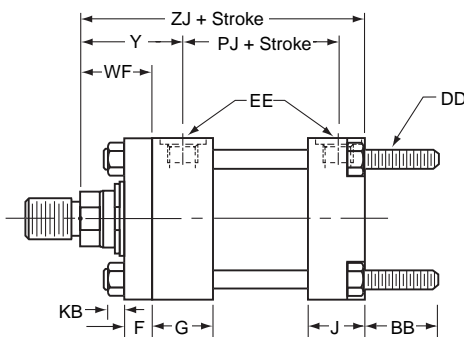

Style TD
Tie Rods Extended Both Ends
(ISO Style MX1)

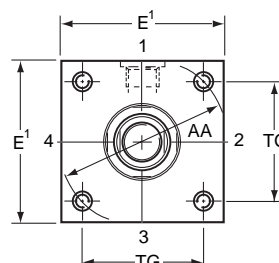
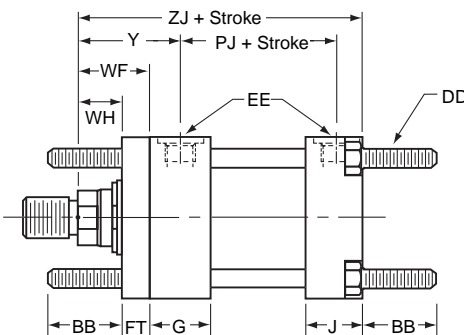

¹Head depth increased by 5mm to accommodate port on 25mm and 32mm bore cylinders – see 25 & 32mm Bore Head data page.

Dimensions – TB, TC & TD See also Rod End Dimensions and Mounting Information

Bore ø	AA	BB	DD	E	EE BSP/G inches	F	FT	G	J	KB	TG	WF	WH	Y	+ Stroke	
															PJ	ZJ
25	40	19	M5x0.8	40 ¹	1/4	10	10	40	25	4	28.3	25	15	50	53	114
32	47	24	M6x1	45 ¹	1/4	10	10	40	25	5	33.2	35	25	60	56	128
40	59	35	M8x1	63	3/8	10	10	45	38	6.5	41.7	35	25	62	73	153
50	74	46	M12x1.25	75	1/2	16	16	45	38	10	52.3	41	25	67	74	159
63	91	46	M12x1.25	90	1/2	16	16	45	38	10	64.3	48	32	71	80	168
80	117	59	M16x1.5	115	3/4	20	20	50	45	13	82.7	51	31	77	93	190
100	137	59	M16x1.5	130	3/4	22	22	50	45	13	96.9	57	35	82	101	203
125	178	81	M22x1.5	165	1	22	22	58	58	18	125.9	57	35	86	117	232
160	219	92	M27x2	205	1	25	25	58	58	22	154.9	57	32	86	130	245
200	269	115	M30x2	245	1-1/4	25	25	76	76	24	190.2	57	32	98	165	299

All dimensions are in millimeters unless otherwise stated.

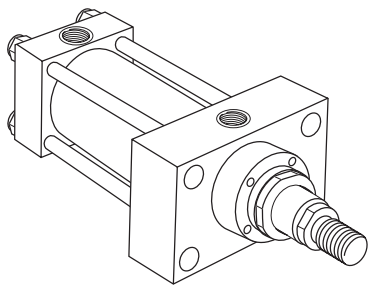

Style JJ
Head Rectangular Flange
(ISO Style ME5)

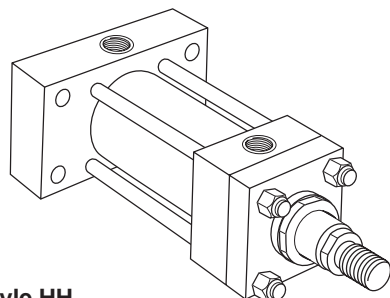
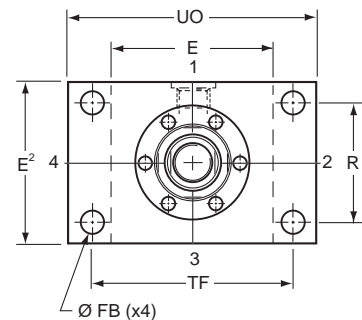
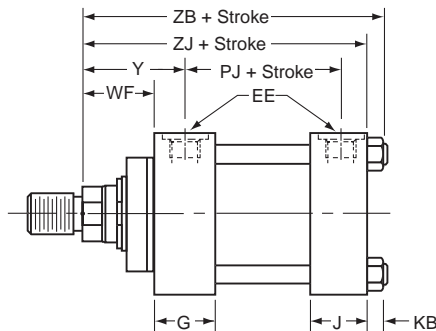

Style HH
Cap Rectangular Flange
(ISO Style ME6)

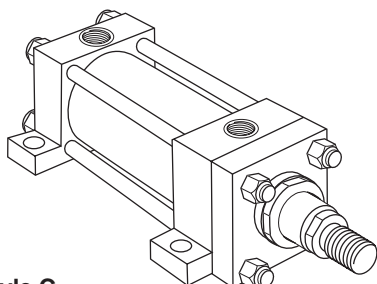
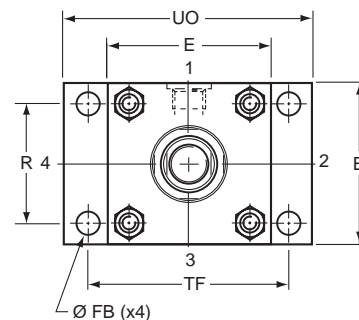
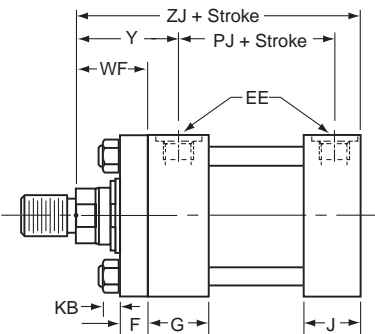

Style C
Side Lugs
(ISO Style MS2)

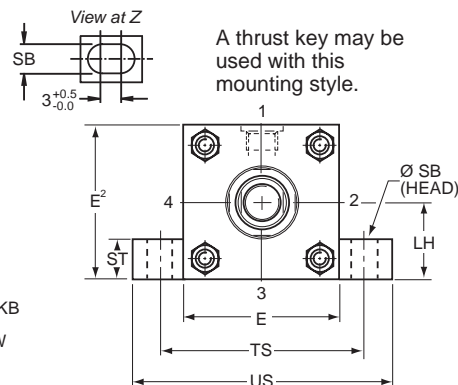
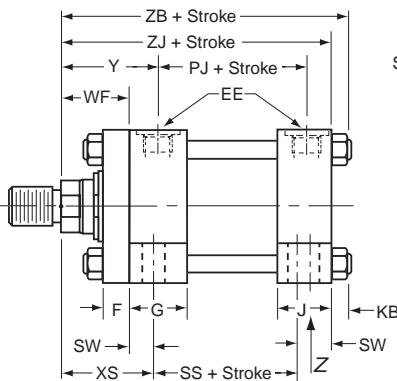

¹Head depth increased by 5mm to accommodate port on 25mm and 32mm bore cylinders.

²On 25mm and 32 mm bore C mount and JJ mount cylinders with port in position 2 or 4, head depth E is increased by 5mm in position 1.

Dimensions – JJ, HH & C See also Rod End Dimensions and Mounting Information.

Bore ø	E	EE BSP/G inches	F	FB	G	J	KB	LH h10	R	SB	ST	SW	TF	TS	UO	US	WF	XS	Y	+ Stroke			
																				PJ	SS	ZB	ZJ
25	40 ¹	1/4	10	5.5	40	25	4	19	27	6.6	8.5	8	51	54	65	72	25	33	50	53	72	121	114
32	45 ¹	1/4	10	6.6	40	25	5	22	33	9	12.5	10	58	63	70	84	35	45	60	56	72	137	128
40	63	3/8	10	11	45	38	6.5	31	41	11	12.5	10	87	83	110	103	35	45	62	73	97	166	153
50	75	1/2	16	14	45	38	10	37	52	14	19	13	105	102	130	127	41	54	67	74	91	176	159
63	90	1/2	16	14	45	38	10	44	65	18	26	17	117	124	145	161	48	65	71	80	85	185	168
80	115	3/4	20	18	50	45	13	57	83	18	26	17	149	149	180	186	51	68	77	93	104	212	190
100	130	3/4	22	18	50	45	13	63	97	26	32	22	162	172	200	216	57	79	82	101	101	225	203
125	165	1	22	22	58	58	18	82	126	26	32	22	208	210	250	254	57	79	86	117	130	260	232
160	205	1	25	26	58	58	22	101	155	33	38	29	253	260	300	318	57	86	86	130	129	279	245
200	245	1-1/4	25	33	76	76	24	122	190	39	44	35	300	311	360	381	57	92	98	165	171	336	299

All dimensions are in millimeters unless otherwise stated.

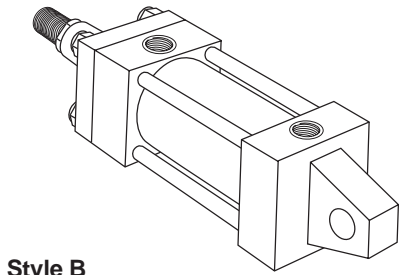

Style B
Cap Fixed Eye
(ISO Style MP3)

Pivot pin not supplied

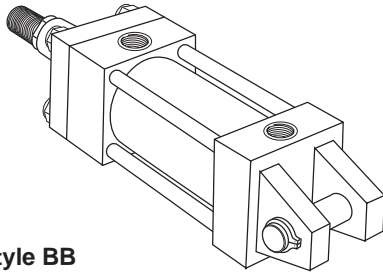
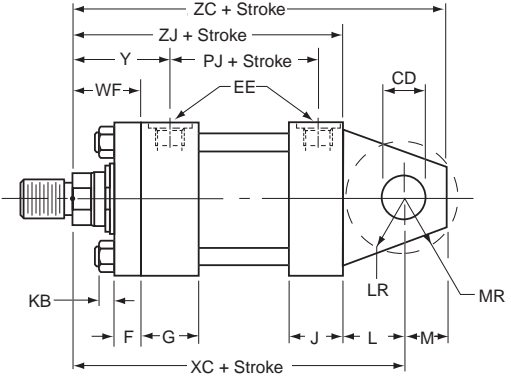
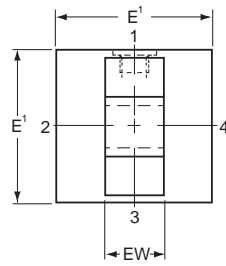

Style BB
Cap Fixed Clevis
(ISO Style MP1)

Supplied complete with pivot pin

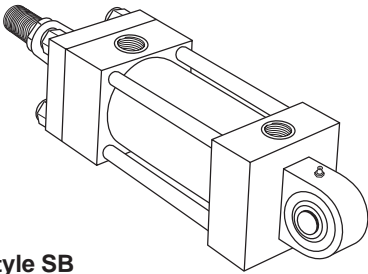
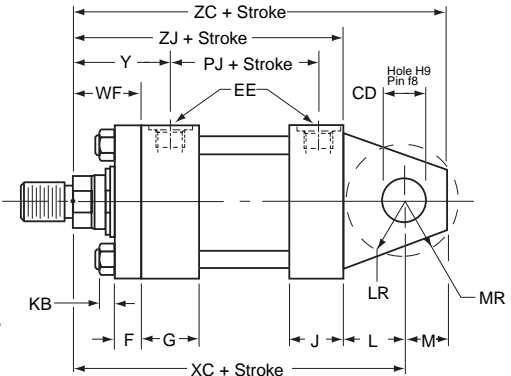
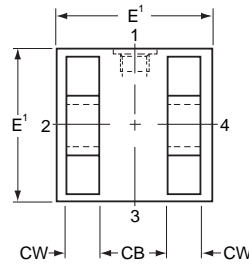

Style SB
Cap Fixed Eye
(ISO Style MP5)

Pivot pin not supplied

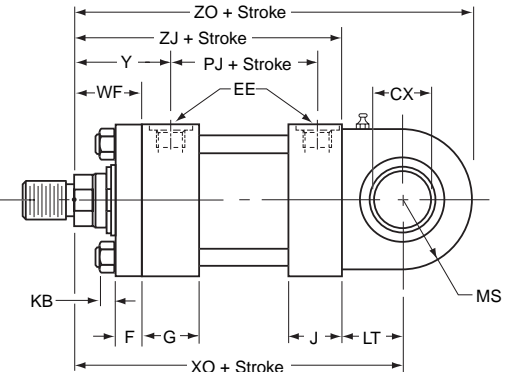
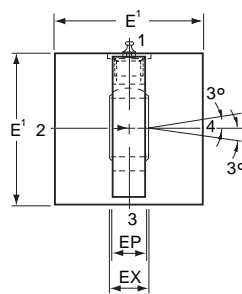

¹Head depth increased by 5mm to accommodate port on 25mm and 32mm bore cylinders – see 25 & 32mm Bore Head data page.

Dimensions – B, BB & SB See also Rod End Dimensions and Mounting Information.

Bore Ø	CB A16	CD H9	CW	CX	E	EE BSP/G inches	EP	EW h14	EX	F	G	J	KB	L	LR	LT	M	MR	MS max	WF	Y	+ Stroke					
																						PJ	XC	XO	ZC	ZJ	ZO
25	12	10	6	12-0.008	40 ¹	1/4	8	12	10	10	40	25	4	13	12	16	10	12	20	25	50	53	127	130	137	114	150
32	16	12	8	16-0.008	45 ¹	1/4	11	16	14	10	40	25	5	19	17	20	12	15	22.5	35	60	56	147	148	159	128	170.5
40	20	14	10	20-0.012	63	3/8	13	20	16	10	45	38	6.5	19	17	25	14	16	29	35	62	73	172	178	186	153	207
50	30	20	15	25-0.012	76	1/2	17	30	20	16	45	38	10	32	29	31	20	25	33	41	67	74	191	190	211	159	223
63	30	20	15	30-0.012	90	1/2	19	30	22	16	45	38	10	32	29	38	20	25	40	48	71	80	200	206	220	168	246
80	40	28	20	40-0.012	115	3/4	23	40	28	20	50	45	13	39	34	48	28	34	50	51	77	93	229	238	257	190	288
100	50	36	25	50-0.012	130	3/4	30	50	35	22	50	45	13	54	50	58	36	44	62	57	82	101	257	261	293	203	323
125	60	45	30	60-0.015	165	1	38	60	44	22	58	58	18	57	53	72	45	53	80	57	86	117	289	304	334	232	384
160	70	56	35	80-0.015	205	1	47	70	55	25	58	58	22	63	59	92	59	59	100	57	86	130	308	337	367	245	437
200	80	70	40	100-0.020	245	1-1/4	57	80	70	25	76	76	24	82	78	116	70	76	120	57	98	165	381	415	451	299	535

All dimensions are in millimeters unless otherwise stated.

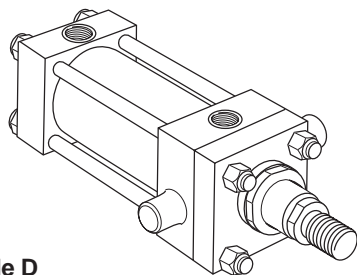

Style D
Head Trunnion
(ISO Style MT1)

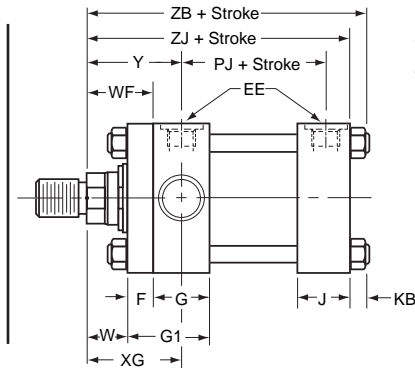

Notes:

A one-piece head and retainer is used on 100mm-200mm bore sizes – G1 dimension. On 160 and 200mm bores, the bolted gland is recessed, with tie rods screwed into the head.

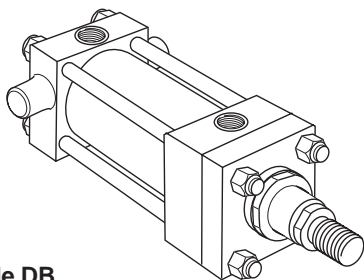
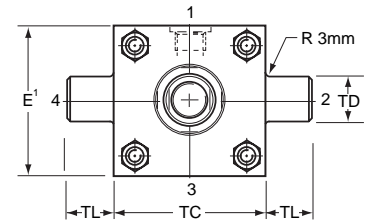

Style DB
Cap Trunnion
(ISO Style MT2)

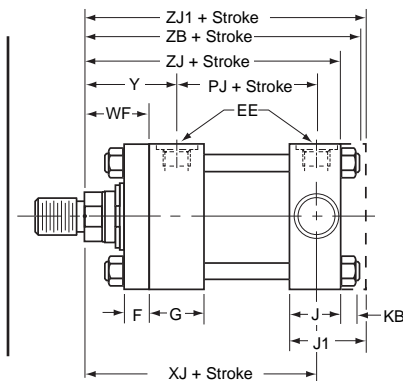

Note:

On 80-200mm bore cylinders, dimension J becomes J1. ZJ1 replaces ZB, and tie rods are screwed directly into the cap.

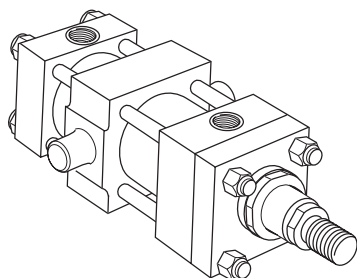
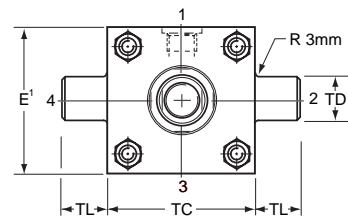

Style DD
Intermediate Fixed Trunnion
(ISO Style MT4)

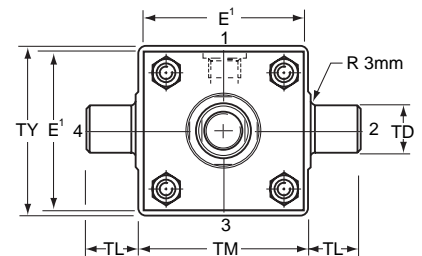
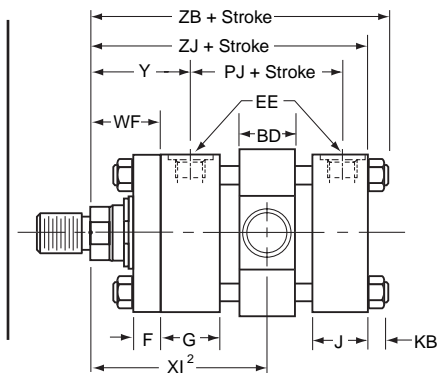

¹Head depth increased by 5mm to accommodate port on 25mm and 32mm bore cylinders – see 25 & 32mm Bore Head data page.

²Dimensions to be specified by customer. See table below for minimum XI dimensions and minimum cylinder stroke.

Dimensions – D, DB & DD See also Rod End Dimensions and Mounting Information.

Bore Ø	BD	E	EE BSP/G inches	F	G	G1	J	J1	KB	TC	TD	TL	TM	TY	W	WF	XG	Y	+ Stroke					Style DD min stroke	Min XI dim'n
																			PJ	XJ	ZJ	ZJ1	ZB		
25	20	40 ¹	1/4	10	40	-	25	-	4	38	12	10	48	45	-	25	44	50	53	101	114	-	121	10	78
32	25	45 ¹	1/4	10	40	-	25	-	5	44	16	12	55	54	-	35	54	60	56	115	128	-	137	10	90
40	30	63	3/8	10	45	-	38	-	6.5	63	20	16	76	76	-	35	57	62	73	134	153	-	166	15	97
50	40	76	1/2	16	45	-	38	-	10	76	25	20	89	89	-	41	64	67	74	140	159	-	176	15	107
63	40	90	1/2	16	45	-	38	-	10	89	32	25	100	95	-	48	70	71	80	149	168	-	185	15	114
80	50	115	3/4	20	50	-	45	50	13	114	40	32	127	127	-	51	76	77	93	168	190	194	212	20	127
100	60	130	3/4	22	50	72	45	58	13	127	50	40	140	140	35	57	71	82	101	187	203	216	225	20	138
125	73	165	1	22	58	80	58	71	18	165	63	50	178	178	35	57	75	86	117	209	232	245	260	25	153
160	90	205	1	25	58	88	58	88	22	203	80	63	215	216	32	57	75	86	130	230	245	275	279	30	161
200	110	245	1-1/4	25	76	108	76	108	24	241	100	80	279	280	32	57	85	98	165	276	299	330	336	30	190

All dimensions are in millimeters unless otherwise stated.

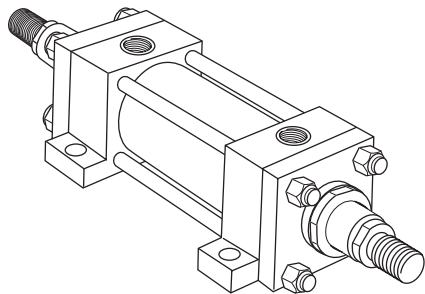

Double Rod Cylinder

Available with Styles TB, TD, JJ, C, D, DD (Style C illustrated)

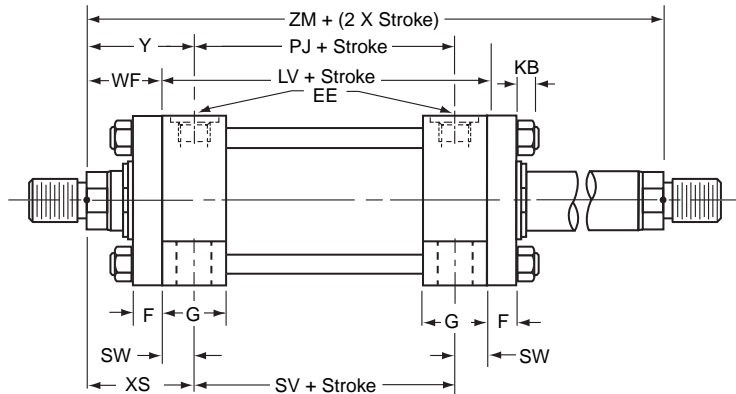

Mounting Styles and Codes

Double rod cylinders are denoted by a 'K' in the ISO cylinder model code.

Dimensions

To obtain dimensional information for double rod cylinders, first select the desired mounting style by referring to the corresponding single rod model. Dimensions for the appropriate single rod model should be supplemented by those from the table opposite to provide a full set of dimensions.

Minimum Stroke Length – Style 9 Rod End

Where a style 9 (female) piston rod end is required on a double rod cylinder with a stroke of 80mm or less, and a bore of 80mm or above, please consult the factory.

Cushioning

Double rod cylinders can be supplied with cushions at either or both ends. Cushioning requirements should be specified by inserting a 'C' in the ordering code. See How To Order page of this section.

Double Rod Cylinders

For double rod cylinders, specify rod number and rod end symbols for both piston rods. A typical model number for a double rod cylinder would be:

100	K	JJ	SHM	R	E	1	4	M	1	4	M	125	M	11	44
-----	---	----	-----	---	---	---	---	---	---	---	---	-----	---	----	----

Bore ø	Rod		Add Stroke			Add 2x Stroke
	No.	MM ø	LV	PJ	SV	ZM
25	1	12	104	53	88	154
	2	18				
32	1	14	108	56	88	178
	2	22				
40	1	18	125	73	105	195
	2	28				
50	1	22	125	74	99	207
	2	36				
	3	28				
63	1	28	127	80	93	223
	2	45				
	3	36				
80	1	36	144	93	110	246
	2	56				
	3	45				
100	1	45	151	101	107	265
	2	70				
	3	56				
125	1	56	175	117	131	289
	2	90				
	3	70				
160	1	70	188	130	130	302
	2	110				
	3	90				
200	1	90	242	160	172	356
	2	140				
	3	110				

All dimensions are in millimeters unless otherwise stated.

Accessory Selection

Accessories for the rod end of a cylinder are selected by reference to the rod end thread, while the same accessories, when used at the cap end, are selected by cylinder bore size. See tables of part numbers below, and on the following pages.

The rod clevises, plain rod eyes and spherical bearings fitted as accessories to the rod end have the same pin diameters as those used at the cylinder cap ends of the corresponding mounting styles – B, BB and SB – when fitted with the No. 1 rod, or the No. 2 or No. 3 rods with Style 7 rod end.

Rod and Cap End Accessories

Accessories for the SHM ISO cylinder include:

- Rod End** – rod clevis, eye bracket and pivot pin
 - plain rod eye, clevis bracket and pivot pin
 - rod eye with spherical bearing
- Cap End** – eye bracket for style BB mounting
 - clevis bracket for style B mounting
 - pivot pin for eye bracket and clevis bracket

Rod Clevis, Eye Bracket and Pivot Pin

Thread KK	Rod Clevis	Eye Bracket	Pivot Pin	Nominal Force kN	Weight kg
M10x1.25	143447	144808	143477	8	0.3
M12x1.25	143448	144809	143478	12.5	0.6
M14x1.5	143449	144810	143479	20	0.8
M16x1.5	143450	144811	143480	32	2.2
M20x1.5	143451	144812	143480	50	2.7
M27x2	143452	144813	143481	80	5.9
M33x2	143453	144814	143482	125	9.4
M42x2	143454	144815	143483	200	17.8
M48x2	143455	144816	143484	320	26.8
M64x3	143456	144817	143485	500	39.0

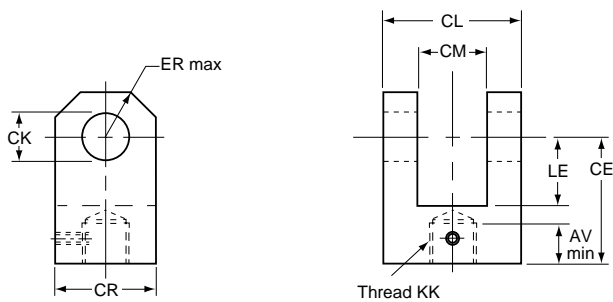

Rod Clevis

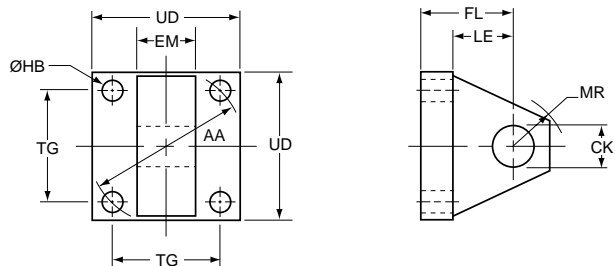

Eye Bracket

All dimensions are in millimeters unless otherwise stated.

Rod Clevis Dimensions

Part No.	AV	CE	CK H9	CL	CM A16	CR	ER	KK	LE	Weight kg
143447	14	32	10	26	12	20	12	M10x1.25	14	0.08
143448	16	36	12	34	16	32	17	M12x1.25	19	0.25
143449	18	38	14	42	20	30	17	M14x1.5	19	0.32
143450	22	54	20	62	30	50	29	M16x1.5	32	1.0
143451	28	60	20	62	30	50	29	M20x1.5	32	1.1
143452	36	75	28	83	40	60	34	M27x2	39	2.3
143453	45	99	36	103	50	80	50	M33x2	54	2.6
143454	56	113	45	123	60	102	53	M42x2	57	5.5
143455	63	126	56	143	70	112	59	M48x2	63	7.6
143456	85	168	70	163	80	146	78	M64x3	83	13.0

Eye Bracket Dimensions

Part No.	CK H9	EM h13	FL	MR max	LE min	AA	HB	TG	UD
144808	10	12	23	12	13	40	5.5	28.3	40
144809	12	16	29	17	19	47	6.6	33.2	45
144810	14	20	29	17	19	59	9	41.7	65
144811	20	30	48	29	32	74	13.5	52.3	75
144812	20	30	48	29	32	91	13.5	64.3	90
144813	28	40	59	34	39	117	17.5	82.7	115
144814	36	50	79	50	54	137	17.5	96.9	130
144815	45	60	87	53	57	178	26	125.9	165
144816	56	70	103	59	63	219	30	154.9	205
144817	70	80	132	78	82	269	33	190.2	240

Pivot Pin for Clevis Bracket and Plain Rod Eye – Dimensions

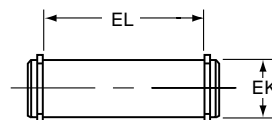

Part No.	EK f8	EL	Weight kg
143477	10	29	0.02
143478	12	37	0.05
143479	14	45	0.08
143480	20	66	0.2
143481	28	87	0.4
143482	36	107	1.0
143483	45	129	1.8
143484	56	149	4.2
143485	70	169	6.0

Eye Bracket – Cap End Mounting for Style BB

Bore ϕ	Eye Bracket	Nominal Force kN	Weight kg
25	144808	8	0.2
32	144809	12.5	0.3
40	144810	20	0.4
50	144811	32	1.0
63	144812	50	1.4
80	144813	80	3.2
100	144814	125	5.6
125	144815	200	10.5
160	144816	320	15.0
200	144817	500	20.0

Plain Rod Eye, Clevis Bracket and Pivot Pin

Thread KK	Plain Rod Eye	Clevis Bracket	Pivot Pin	Nominal Force kN	Weight kg
M10x1.25	143457	143646	143477	8	0.5
M12x1.25	143458	143647	143478	12.5	1.0
M14x1.5	143459	143648	143479	20	1.3
M16x1.5	143460	143649	143480	32	3.2
M20x1.5	143461	143649	143480	50	3.8
M27x2	143462	143650	143481	80	6.9
M33x2	143463	143651	143482	125	12.5
M42x2	143464	143652	143483	200	26.0
M48x2	143465	143653	143484	320	47.0
M64x3	143466	143654	143485	500	64.0

Plain Rod Eye/Knuckle Dimensions

Part No.	AW	CA	CB	CD	CK H9	EM h13	ER	KK	LE	Weight kg
143457	14	32	18	9	10	12	12	M10x1.25	13	0.08
143458	16	36	22	11	12	16	17	M12x1.25	19	0.15
143459	18	38	20	12.5	14	20	17	M14x1.5	19	0.22
143460	22	54	30	17.5	20	30	29	M16x1.5	32	0.5
143461	28	60	30	20	20	30	29	M20x1.5	32	1.1
143462	36	75	40	25	28	40	34	M27x2	39	1.5
143463	45	99	50	35	36	50	50	M33x2	54	2.5
143464	56	113	65	50	45	60	53	M42x2	57	4.2
143465	63	126	90	56	56	70	59	M48x2	63	11.8
143466	85	168	110	70	70	80	78	M64x3	83	17.0

Clevis Bracket Dimensions

Part No.	CK H9	CM A16	CW	FL	MR max	HB	LE min	RC	TB	UR	UH
143646	10	12	6	23	12	5.5	13	18	47	35	60
143647	12	16	8	29	17	6.6	19	24	57	45	70
143648	14	20	10	29	17	9	19	30	68	55	85
143649	20	30	15	48	29	13.5	32	45	102	80	125
143650	28	40	20	59	34	17.5	39	60	135	100	170
143651	36	50	25	79	50	17.5	54	75	167	130	200
143652	45	60	30	87	53	26	57	90	183	150	230
143653	56	70	35	103	59	30	63	105	242	180	300
143654	70	80	40	132	78	33	82	120	300	200	360

Clevis Bracket – For Style B

Bore ϕ	Clevis Bracket	Nominal Force kN	Weight kg
25	143646	8	0.4
32	143647	12.5	0.8
40	143648	20	1.0
50	143649	32	2.5
63	143649	50	2.5
80	143650	80	5.0
100	143651	125	9.0
125	143652	200	20.0
160	143653	320	31.0
200	143654	500	41.0

Plain Rod Eye/Knuckle

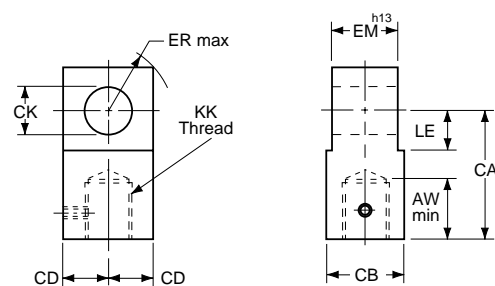

Clevis Bracket

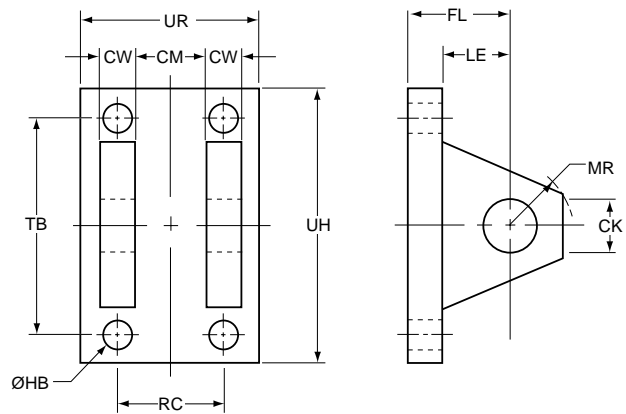

Pivot Pin for Clevis Bracket and Plain Rod Eye – Dimensions

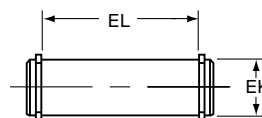

Part No.	EK f8	EL	Weight kg
143477	10	29	0.02
143478	12	37	0.05
143479	14	45	0.08
143480	20	66	0.2
143481	28	87	0.4
143482	36	107	1.0
143483	45	129	1.8
143484	56	149	4.2
143485	70	169	6.0

All dimensions are in millimeters unless otherwise stated.

**Rod Eye with Spherical Bearing,
 Mounting Bracket and Pivot Pin**

Thread KK	Rod Eye with Spherical Bearing	Mounting Bracket and Pivot Pin	Nominal Force kN	Weight kg
M10x1.25	145254	145530	8	0.2
M12x1.25	145255	145531	12.5	0.3
M14x1.5	145256	145532	20	0.4
M16x1.5	145257	145533	32	0.7
M20x1.5	145258	145534	50	1.3
M27x2	145259	145535	80	2.3
M33x2	145260	145536	125	4.4
M42x2	145261	145537	200	8.4
M48x2	145262	145538	320	15.6
M64x3	145263	145539	500	28.0

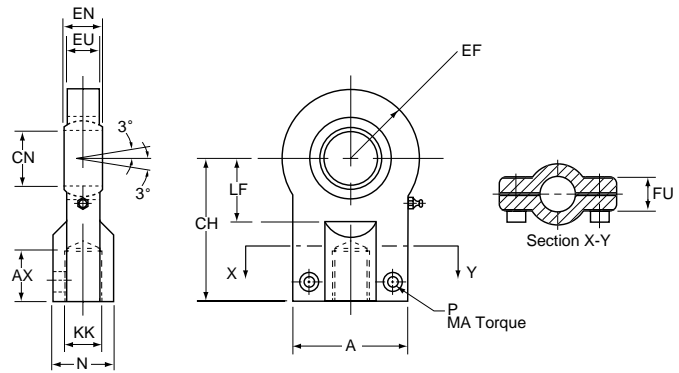

Rod Eye with Spherical Bearing

All spherical bearings should be re-packed with grease when servicing. In unusual or severe working conditions, consult the factory regarding the suitability of the bearing chosen.

Rod Eye with Spherical Bearing Dimensions

Part No.	A max	AX min	EF max	CH	CN	EN	EU	FU	KK	LF min	N max	MA max Nm	P
145254	40	15	20	42	12 -0.008	10 -0.012	8	13	M10x1.25	16	17	10	M6
145255	45	17	22.5	48	16 -0.008	14 -0.012	11	13	M12x1.25	20	21	10	M6
145256	55	19	27.5	58	20 -0.012	16 -0.012	13	17	M14x1.5	25	25	25	M8
145257	62	23	32.5	68	25 -0.012	20 -0.012	17	17	M16x1.5	30	30	25	M8
145258	80	29	40	85	30 -0.012	22 -0.012	19	19	M20x1.5	35	36	45	M10
145259	90	37	50	105	40 -0.012	28 -0.012	23	23	M27x2	45	45	45	M10
145260	105	46	62.5	130	50 -0.012	35 -0.012	30	30	M33x2	58	55	80	M12
145261	134	57	80	150	60 -0.015	44 -0.015	38	38	M42x2	68	68	160	M16
145262	156	64	102.5	185	80 -0.015	55 -0.015	47	47	M48x2	92	90	310	M20
145263	190	86	120	240	100 -0.020	70 -0.020	57	57	M64x3	116	110	530	M24

Mounting Bracket and Pivot Pin Dimensions - For Style SB

Part No.	CF K7/h6	CG +0.1, +0.3	CO N9	CP	FM js11	FO js14	GL js13	HB	KC 0, +0.30	LG	LJ	LO	RE js13	SR max	TA js13	UJ	UK
145530	12	10	10	30	40	16	46	9	3.3	28	29	56	55	12	40	75	60
145531	16	14	16	40	50	18	61	11	4.3	37	38	74	70	16	55	95	80
145532	20	16	16	50	55	20	64	14	4.3	39	40	80	85	20	58	120	90
145533	25	20	25	60	65	22	78	16	5.4	48	49	98	100	25	70	140	110
145534	30	22	25	70	85	24	97	18	5.4	62	63	120	115	30	90	160	135
145535	40	28	36	80	100	24	123	22	8.4	72	73	148	135	40	120	190	170
145536	50	35	36	100	125	35	155	30	8.4	90	92	190	170	50	145	240	215
145537	60	44	50	120	150	35	187	39	11.4	108	110	225	200	60	185	270	260
145538	80	55	50	160	190	35	255	45	11.4	140	142	295	240	80	260	320	340
145539	100	70	63	200	210	35	285	48	12.4	150	152	335	300	100	300	400	400

Cap Mounting Bracket and Pivot Pin

Bore ϕ	Mounting Bracket and Pivot Pin	Nominal Force kN	Weight kg
25	145530	8	0.6
32	145531	12.5	1.3
40	145532	20	2.1
50	145533	32	3.2
63	145534	50	6.5
80	145535	80	12.0
100	145536	125	23.0
125	145537	200	37.0
160	145538	320	79.0
200	145539	500	140.0

Mounting Bracket and Pivot Pin

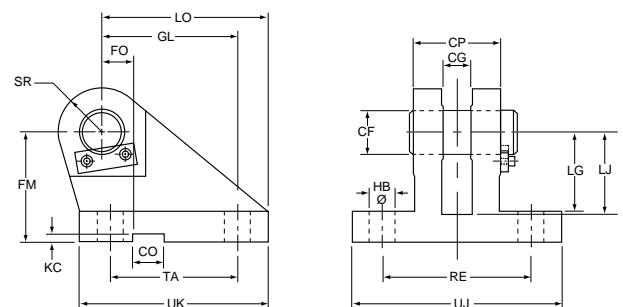

All dimensions are in millimeters unless otherwise stated.

How to Order ISO Cylinders

Data Required On All Cylinder Orders

When ordering SHM Series cylinders, be sure to specify each of the following requirements:

(NOTE: – Duplicate cylinders can be ordered by giving the SERIAL NUMBER from the nameplate of the original cylinder. Factory records supply a quick, positive identification.)

a) Bore Size

b) Mounting Style

Specify your choice of mounting style – as shown and dimensioned in this catalog. If double rod is required, specify “with double rod.”

c) Series Designation (“SHM”)

d) Length of Stroke

e) Piston Rod Diameter

Call out rod diameter or rod code number. In SHM Series cylinders, standard rod diameters (Code No. 1) will be furnished if not otherwise specified, unless length of stroke makes the application questionable.

f) Piston Rod End Thread Style

Call out thread style number or specify dimensions. Thread style number 4 will be furnished if not otherwise specified.

g) Cushions (if required)

Specify “Cushion-head end,” “Cushion-cap end” or “Cushion-both ends” as required. If cylinder is to have a double rod and only one cushion is required, be sure to specify clearly which end of the cylinder is to be cushioned.

h) Piston

Schrader Bellows B style pistons are standard. Fluorocarbon also available.

i) Ports

BSP (ISO 228) are standard.

j) Fluid Medium

SHM Series hydraulic cylinders are equipped with seals for use with hydraulic oil. If other than hydraulic oil will be used, consult factory.

ADDITIONAL DATA is required on orders for cylinders with special modifications.
For further information, consult factory.

Service Policy

On cylinders returned to the factory for repairs, it is standard policy for the Industrial Cylinder Division to make such part replacements as will put the cylinder in as good as new condition. Should the condition of the returned cylinder be such that expenses for repair would exceed the costs of a new one, you will be notified.

Address all correspondence to Service Department at your nearest regional plant listed in the pages of this catalog.

NOTES



Contents

Series CHE

Cylinder Features	147
Cylinder Weights and Force	148
Model Code & Standard Specifications	149
Mounting Styles	150-157
Global Position Sensing Switches	158
Solid State Switches/Wiring Connection	159
Reed Switches/Wiring Connection	160
Switch Mounting/End-of-Stroke Location	161
CPS Sensors	162-163
Cordsets	164

Series CHD

Cylinder Features	167
Cylinder Weights and Force	168
Model Code & Standard Specifications	169
Mounting Styles	170-187
Interface Machining	188

Series CHE & CHD

Minimum Rod Extension	189
Cylinder Mounting	190-191
Parts Identification	192
Seal Kits/Gland & Cap Spanner Holes	193

Choose Series CHE & CHD Compact Hydraulic Cylinders

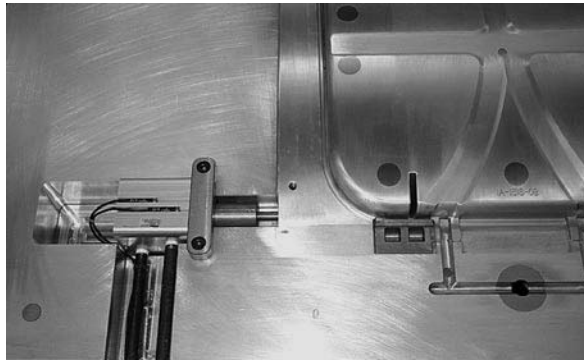

When mounting space is at a premium and the application demands a high force cylinder...



Series CHE is your choice when cylinder position indication is required and when operating pressures are up to 140 bar (depending on bore size).



Series CHD steel body cylinders are your best choice for high force requirements with operating pressures up to 207 bar. Available foot mounting with manifold ports enhances machine design flexibility.

Series CHE Cylinder Features

Primary Seal – polyurethane rod seal with multiple sealing edges is self-compensating and self relieving to withstand pressure variations and conform to mechanical deflection that may occur.

Piston Rod – Medium carbon steel, hard chrome plated and polished.

Ports – SAE O-ring ports are standard.

OPTIONAL PORTS
 NPTF and BSPP ports are also available.

Bi-directional Piston Seal – Polyurethane seal ring with energizer provides leak-free performance.

Non-Metallic Wear Band – improves resistance to bearing loads and provides support for magnet.

Secondary Seal – Rod Wiper – wipes clean any oil film adhering to the rod on the extend stroke and cleans the rod on the return stroke.

Piston Rod End – four standard styles. Special ends available.

Low Profile Switches – mount in body grooves and do not extend beyond the cylinder envelope.

Rod Gland – nodular iron bearing with RoHS compliant zinc plating for corrosion resistance. Optional pilot gland (shown) available at no additional cost.

Cylinder Body – corrosion resistant aluminum alloy. Hard anodized I.D for long wear. Sensor mounting grooves on three sides.

Magnetic Piston Option – for solid state or reed switch actuation.

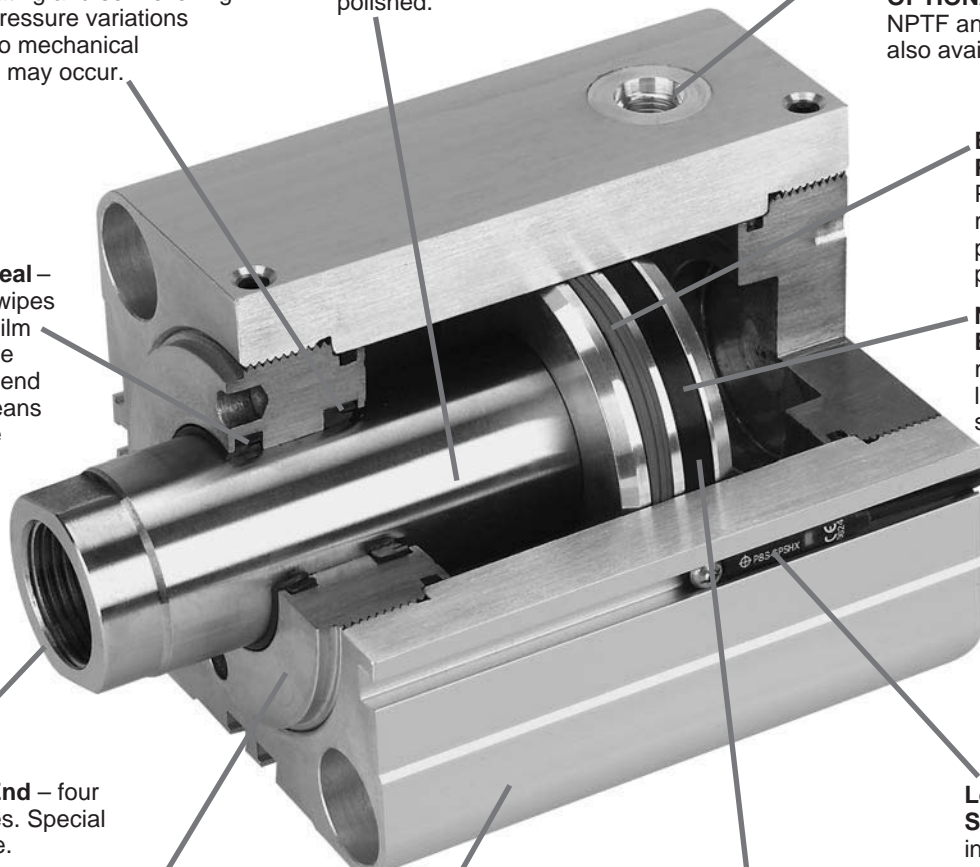

CHE Compact Hydraulic Cylinders...

have a lower profile than tie rod construction cylinders with switches installed.

Optional Pilot Gland...

offers added bearing area to increase service life and also improves alignment of cylinder and load.

<p>CHE offers mid-stroke piston sensing</p>	<table border="0"> <tr> <td data-bbox="812 1453 1055 1942"> <p>Standard Gland</p> <p>Rod Bearing Length</p> </td> <td data-bbox="1055 1453 1484 1942"> <p>Pilot Gland</p> <p>Rod Bearing Length</p> </td> </tr> <tr> <td colspan="2" style="text-align: center;"> <p>Average 63% more bearing area with Pilot Gland</p> </td> </tr> <tr> <td colspan="2" style="text-align: center;"> <p>(18mm rod glands depicted)</p> </td> </tr> <tr> <td colspan="2" style="text-align: center;"> <p>Use pilot cap to improve alignment for rear mount applications</p> </td> </tr> </table>	<p>Standard Gland</p> <p>Rod Bearing Length</p>	<p>Pilot Gland</p> <p>Rod Bearing Length</p>	<p>Average 63% more bearing area with Pilot Gland</p>		<p>(18mm rod glands depicted)</p>		<p>Use pilot cap to improve alignment for rear mount applications</p>	
<p>Standard Gland</p> <p>Rod Bearing Length</p>	<p>Pilot Gland</p> <p>Rod Bearing Length</p>								
<p>Average 63% more bearing area with Pilot Gland</p>									
<p>(18mm rod glands depicted)</p>									
<p>Use pilot cap to improve alignment for rear mount applications</p>									

Theoretical Push and Pull Forces

The cylinder output forces are derived from the formula:

$$F = \frac{P \times A}{10000}$$

Where F = Force in kN.

P = Pressure at the cylinder in bar.

A = Effective area of cylinder piston in square mm.

To determine the bore size for the application take the following steps.

1. Select the Operating Pressure column closest to that desired.

2. In the same column, identify the force required to move the load (always rounding up). If the piston rod is in compression use the 'Push' row and if the piston rod is in tension use the 'Pull' row.

3. In the row to the left is the bore required.

If the cylinder envelope dimensions are too large for the application, increase the operating pressure to the maximum pressure in the table below, if possible, and repeat steps 1 - 3.

Push and Pull Force in kN

Bore Ø	Rod Ø	Operating Direction	Piston Area (mm²)	Operating Pressure (Bar)						
				20	40	60	80	100	120	140
20	12	Push	314	0.63	1.26	1.88	2.51	3.14	3.77	4.40
		Pull	201	0.40	0.80	1.21	1.61	2.01	2.41	2.81
25	14	Push	491	0.98	1.96	2.95	3.93	4.91	5.89	6.87
		Pull	337	0.67	1.35	2.02	2.70	3.37	4.04	4.72
32	18	Push	804	1.61	3.22	4.83	6.43	8.04	9.65	11.3
		Pull	550	1.10	2.20	3.30	4.40	5.50	6.60	7.70
40	22	Push	1,257	2.51	5.03	7.54	10.1	12.6	15.1	17.6
		Pull	877	1.75	3.51	5.26	7.01	8.77	10.5	12.3
50	28	Push	1,963	3.93	7.85	11.8	15.7	19.6	23.6	-
		Pull	1,348	2.70	5.39	8.09	10.8	13.5	16.2	-
63	36	Push	3,117	6.23	12.5	18.7	24.9	31.2	-	-
		Pull	2,099	4.20	8.40	12.6	16.8	21.0	-	-
80	45	Push	5,027	10.1	20.1	30.2	40.2	50.3	-	-
		Pull	3,436	6.87	13.7	20.6	27.5	34.4	-	-
100	56	Push	7,854	15.7	31.4	47.1	62.8	78.5	-	-
		Pull	5,391	10.8	21.6	32.3	43.1	53.9	-	-

**Series CHE
Pressure Rating**

Bore Ø	Maximum Working Pressure in bar
20	140
25	140
32	140
40	140
50	120
63	100
80	100
100	100

Equivalents

- 1 kN = 224.81 pounds force
- 1 bar = 14.50 psi
- 1 mm = .03937 inch
- 1 mm² = .00155 inch²

Cylinder Weights

To determine the weight of a Series CHE cylinder, first select the proper basic zero stroke weight for the mounting required, and then calculate the weight of the

cylinder stroke and add the result to the basic weight. For extra rod extension, use piston rod weights per mm in Table C.

Table A Single Rod End CHE Cylinder Weights in kg.

Bore Ø	Rod Ø	Single Rod Cylinders									
		Basic Weight at Zero Stroke				Per mm Stroke	Basic Weight at Zero Stroke				Per mm Stroke
		T		TN, TR			J, H		CA		
		PC 3 ¹	PC B ¹	PC 3 ¹	PC B ¹		PC 3 ¹	PC B ¹	PC 3 ¹	PC B ¹	
20	12	0.24	0.25	0.25	0.26	0.004	0.51	0.52	0.48	0.49	0.005
25	14	0.34	0.36	0.35	0.37	0.005	0.71	0.73	0.69	0.71	0.006
32	18	0.62	0.66	0.64	0.68	0.009	1.14	1.18	1.28	1.33	0.009
40	22	0.92	0.99	0.95	1.02	0.011	1.86	1.93	2.00	2.06	0.013
50	28	1.38	1.50	1.44	1.55	0.015	2.97	3.09	3.12	3.24	0.017
63	36	2.33	2.54	2.42	2.62	0.021	4.33	4.54	5.14	5.34	0.025
80	45	4.20	4.66	4.34	4.80	0.031	7.68	8.14	8.67	9.13	0.036
100	56	8.02	8.86	8.23	9.08	0.045	14.7	15.6	15.6	16.4	0.051

Table C Piston rod weights in kg.

Rod Ø	Piston Rod Weight per mm
12	0.001
14	0.001
18	0.002
22	0.003
28	0.005
36	0.008
45	0.012
56	0.019

Table B Double Rod End CHE Cylinder Weights in kg.

Bore Ø	Rod Ø	Double Rod Cylinders									
		Basic Weight at Zero Stroke				Per mm Stroke	Basic Weight at Zero Stroke				Per mm Stroke
		T		TN			J		CA		
		PC 3 ¹	PC B ¹	PC 3 ¹	PC B ¹		PC 3 ¹	PC B ¹	PC 3 ¹	PC B ¹	
20	12	0.26	0.28	0.28	0.29	0.005	0.53	0.55	0.50	0.51	0.006
25	14	0.37	0.40	0.39	0.41	0.007	0.75	0.77	0.72	0.75	0.008
32	18	0.68	0.72	0.71	0.75	0.011	1.21	1.25	1.35	1.39	0.011
40	22	1.02	1.09	1.06	1.13	0.014	1.97	2.04	2.10	2.17	0.016
50	28	1.59	1.70	1.64	1.75	0.020	3.18	3.29	3.33	3.44	0.022
63	36	2.75	2.95	2.84	3.04	0.029	4.75	4.95	5.56	5.76	0.033
80	45	5.00	5.45	5.14	5.59	0.043	8.48	8.93	9.47	9.92	0.048
100	56	9.64	10.5	9.86	10.7	0.065	16.3	17.2	17.2	18.1	0.071

Equivalent

1 kg = 2.2046 pounds

Note 1: PC 3 = with Piston Code 3 or 5 (Magnetic Piston), PC B = with Piston Code 9 or B (Non-Magnet Piston)

Model Code & Standard Specifications

Model Ordering Code for CHE

32		T	CHE	3	T			9		A	25
Bore Dia.	Double Rod Cylinder	Mounting Style	Series	Piston	Ports	Seals	Special Modification	Piston Rod Thread Style	Piston Rod Thread Style (For Dbl. Rod)	Piston Rod Thread Type	Stroke
Specify: (Bore dia. in mm) 20 25 32 40 50 63 80 100	Use "K" only if double rod cylinder is required.	Specify: T = Std. Mount TN = Std. Mount with pilot gland TR = Std. Mount with cap pilot CA = Side Lug Mount J = Head Rectangular Flange H = Cap Rectangular Flange	CHE	Specify: 3 = Magnetic piston ¹ 5 = Magnetic piston with bronze cap & gland ² 9 = Non-magnetic piston with bronze cap, & gland B = Non-magnetic piston.	Specify: T = SAE Ports U = NPTF Ports R = BSPP Ports	Leave blank for std. Nitrile Seals V = Fluoro-carbon	Use "S" for Special Modification other than rod end, and specify modification.	Specify: 4 = Small Male 8 = Intermediate Male 9 = Female 55 = Flange Coupler 3 = Special ³	Specify: 4 = Small Male 8 = Intermediate Male 9 = Female 55 = Flange Coupler 3 = Special ³	Specify: A = Imperial (UNF or UNC) M = Metric ⁴	Specify Stroke Length Required in mm ⁵ .

Maximum Stroke

Bore Ø	Stroke in mm
20	75
25	75
32	150
40	150
50	150
63	150
80	150
100	130

Intermediate strokes in 1mm increments are available.

Shaded boxes identify required model number fields.

- ¹ Order required Solid State or Reed Switches as separate items. See reed switch & solid state switch pages for specifications and part numbers.
- ² Bronze cap and gland required for CPS linear cylinder position sensor (must be ordered separately).
- ³ To order thread style 3, specify "3" and give the desired dimensions for KK, A, and W (or WP or WR depending on mounting) or furnish a dimensioned sketch.
- ⁴ Always use M for rod style 55.
- ⁵ See Maximum Stroke chart at right.

Standard Specifications

- 6 Standard mounting styles
- Bore sizes – 20mm to 100mm
- Piston Rod Diameter – 12mm to 56mm
- Single and double rod construction available
- Strokes up to 150mm depending on bore size (see table above).
- Working pressure up to 140 bar (depending on bore size)
- Temperature range – -23°C to +121°C (depending on seal class)
- Reference ISO 16656: 2004

Seal Classes	Typical Fluids	Temperature Range
1 – Standard Nitrile & Polyurethane	Hydraulic Oil, MIL-H-5606 Oil	-23°C (-10°F) to +74°C (+165°F)
5 – Optional (At extra cost) Fluorocarbon Seals	High Temperature	-23°C (-10°F) to +121°C (+250°F) Class 5 seals may be operated up to +204°C (+400°F) with reduced service life

Note: Class 5 seals are not suitable for use with Skydrol fluid, but can be used with hydraulic oil if desired.

Style T Through Bolt Mount – Single Rod End – 20mm to 100mm Bore Size

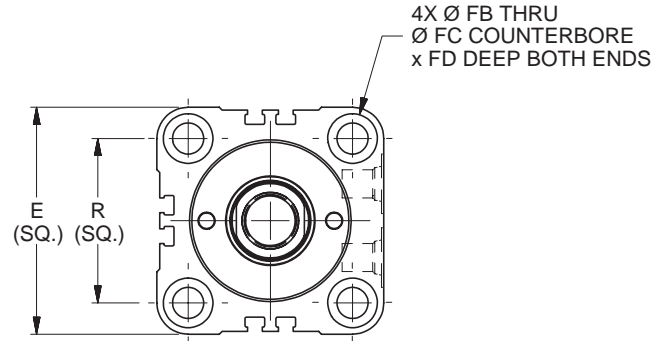
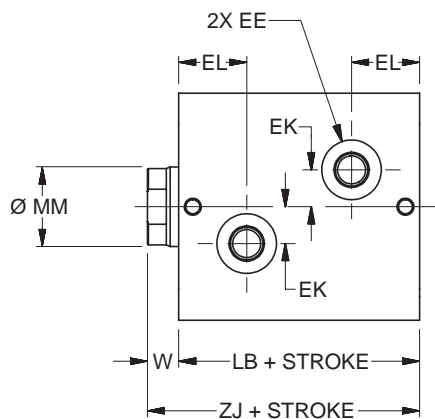

T Mount Single Rod End – Envelope and Mounting Dimensions

Bore Ø	E	EE			EK	EL	FB Ø	FC Ø	FD	R	W	Add Stroke	
		SAE	NPTF	BSP								LB	ZJ
20	43 ¹	#2 ²	1/8	G-1/8	6	16.5	5.5	9.5	5.4	30	8	43	51
25	49	#2 ²	1/8	G-1/8	8	17.5	5.5	9.5	5.4	36	8	45	53
32	62	#4	1/4	G-1/4	11	20.5	7	11	6.5	47	10	51	61
40	70	#4	1/4	G-1/4	12	21	9	14	8.6	52	10	55	65
50	80	#4	1/4	G-1/4	14	22.5	11	17.5	10.8	58	11	60	71
63	94	#4	1/4	G-1/4	17	26	13.5	20	13	69	13	67	80
80	114	#6	3/8	G-3/8	20	29.5	16	23	15.2	86	17	78	95
100	138	#6	3/8	G-3/8	25	35	18	26	17.5	106	26	96	122

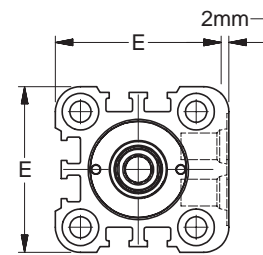

**Port Face Extension
20mm Bore Only**

¹ Port face on 20mm bore is extended 2mm. See port face extension drawing.

² Parker Triple-Lok™ Straight Thread Connector SAE #2 to 1/4" 37° flare can be used when this port thread is required. Contact your local Parker Tube Fitting distributor and specify part number 4-2 F5OX.

T Mount Single Rod End – Rod Dimensions

Bore Ø	MM Rod Ø	Rod End														Rod Extension Dimensions		
		Style 9M		Style 4M		Style 9A		Style 4A		Style 8A		Style 55M				C	D	NA
		KK	A	KK	A	KK	A	KK	A	CC	A	AD	AE	AF	AM			
20	12	M8x1.25	10	M8x1	14	5/16-24	10	5/16-24	14	3/8-24	16	8	3	6	11	6	10	11
25	14	M10x1.5	12	M10x1.25	16	3/8-24	12	3/8-24	16	1/2-20	18	12	4	8	13	6	12	13
32	18	M12x1.75	15	M12x1.25	18	7/16-20	15	7/16-20	18	9/16-18	25	16	6	10	16	8	15	17
40	22	M16x2	20	M16x1.5	22	5/8-18	20	5/8-18	22	3/4-16	30	20	8	12	20	8	19	21
50	28	M20x2.5	24	M20x1.5	28	3/4-16	24	3/4-16	28	7/8-14	35	24	10	16	25	9	24	27
63	36	M27x3	30	M27x2	36	1-14	30	1-14	36	1 1/4-12	45	28	12	22	33	11	32	35
80	45	M33x3.5	35	M33x2	45	1 1/4-12	35	1 1/4-12	45	1 1/2-12	56	34	14	28	41	13	39	43
100	56	M42x4.5	45	M42x2	56	1 1/2-12	45	1 1/2-12	56	1 3/4-12	70	42	16	35	52	22	48	54

Rod End Dimensions

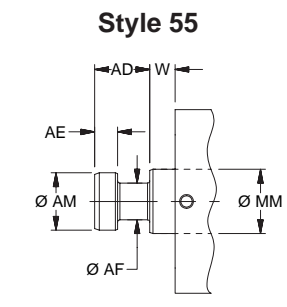
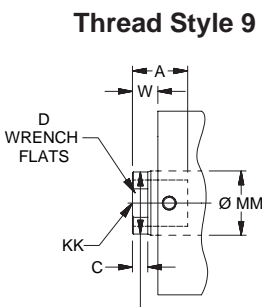
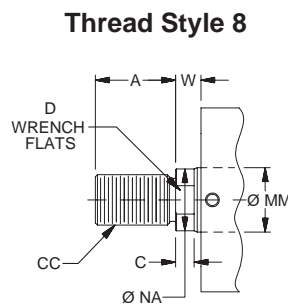
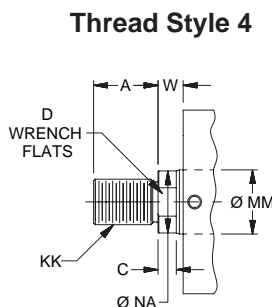

“Special” Thread Style 3
Special thread, extension, rod eye, blank, etc. are also available. To order, specify “Style 3” and give desired dimensions for KK, A, & W. If otherwise special furnish dimensional sketch.

Style T Through Bolt Mount – Double Rod End – 20mm to 100mm Bore Size

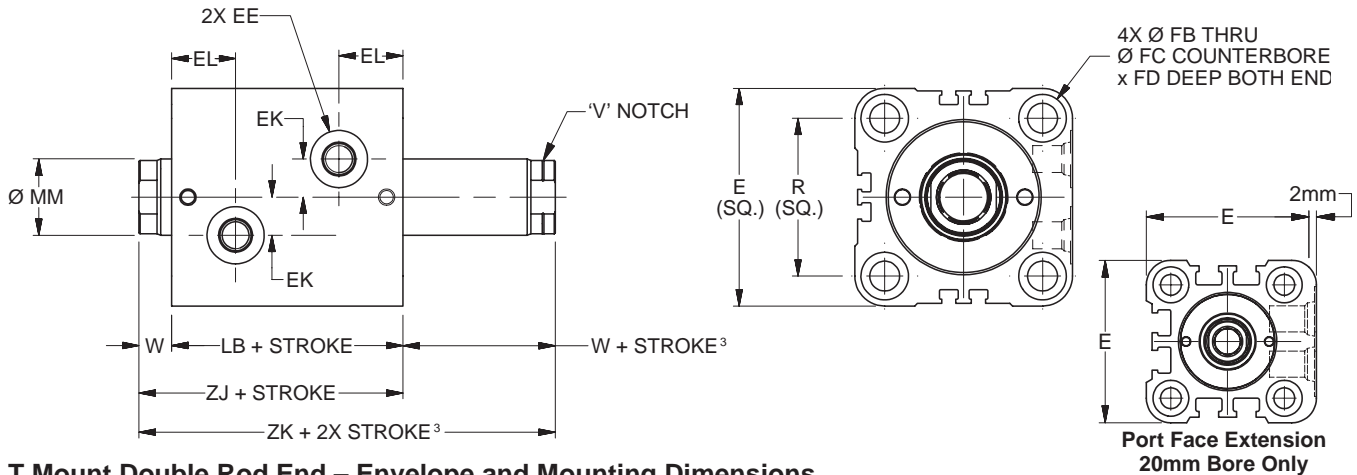

T Mount Double Rod End – Envelope and Mounting Dimensions

Bore Ø	E	EE			EK	EL	FB Ø	FC Ø	FD	LB	R	W ³	Add Stroke		Add 2X Stroke ZK ³
		SAE	NPTF	BSP									LB	ZJ	
20	43 ¹	#2 ²	1/8	G-1/8	6	16.5	5.5	9.5	5.4	43	30	8	43	51	59
25	49	#2 ²	1/8	G-1/8	8	17.5	5.5	9.5	5.4	45	36	8	45	53	61
32	62	#4	1/4	G-1/4	11	20.5	7	11	6.5	51	47	10	51	61	71
40	70	#4	1/4	G-1/4	12	21	9	14	8.6	55	52	10	55	65	75
50	80	#4	1/4	G-1/4	14	22.5	11	17.5	10.8	60	58	11	60	71	82
63	94	#4	1/4	G-1/4	17	26	13.5	20	13	67	69	13	67	80	93
80	114	#6	3/8	G-3/8	20	29.5	16	23	15.2	78	86	17	78	95	112
100	138	#6	3/8	G-3/8	25	35	18	26	17.5	96	106	26	96	122	148

¹ Port face on 20mm bore is extended 2mm. See port face extension drawing.

² Parker Triple-Lok™ Straight Thread Connector SAE #2 to 1/4" 37° flare can be used when this port thread is required. Contact your local Parker Tube Fitting distributor and specify part number 4-2 F5OX.

³ Minimum 'W + Stroke' on V notch rod side may apply. See minimum rod extension page for details.

T Mount Double Rod End – Rod Dimensions

Bore Ø	MM Rod Ø	Rod End														Rod Extension Dimensions		
		Style 9M ³		Style 4M		Style 9A ³		Style 4A		Style 8A		Style 55M				C	D	NA
		KK	A	KK	A	KK	A	KK	A	CC	A	AD	AE	AF	AM			
20	12	M8x1.25	10	M8x1	14	5/16-24	10	5/16-24	14	3/8-24	16	8	3	6	11	6	10	11
25	14	M10x1.5	12	M10x1.25	16	3/8-24	12	3/8-24	16	1/2-20	18	12	4	8	13	6	12	13
32	18	M12x1.75	15	M12x1.25	18	7/16-20	15	7/16-20	18	9/16-18	25	16	6	10	16	8	15	17
40	22	M16x2	20	M16x1.5	22	5/8-18	20	5/8-18	22	3/4-16	30	20	8	12	20	8	19	21
50	28	M20x2.5	24	M20x1.5	28	3/4-16	24	3/4-16	28	7/8-14	35	24	10	16	25	9	24	27
63	36	M27x3	30	M27x2	36	1-14	30	1-14	36	1 1/4-12	45	28	12	22	33	11	32	35
80	45	M33x3.5	35	M33x2	45	1 1/4-12	35	1 1/4-12	45	1 1/2-12	56	34	14	28	41	13	39	43
100	56	M42x4.5	45	M42x2	56	1 1/2-12	45	1 1/2-12	56	1 3/4-12	70	42	16	35	52	22	48	54

Rod End Dimensions

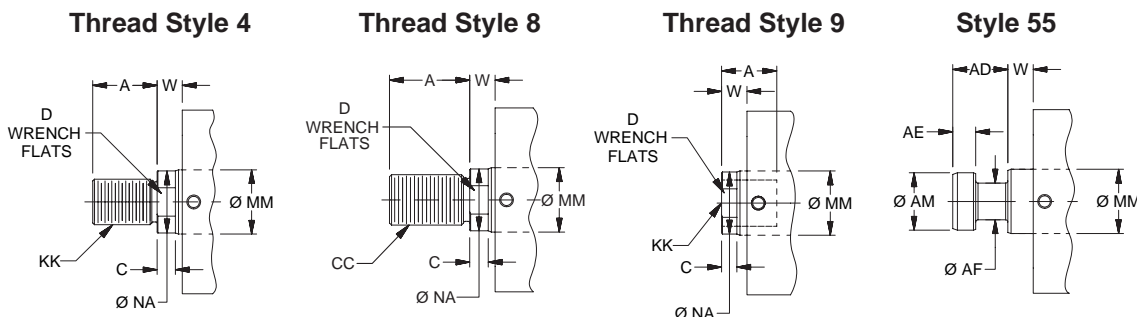

"Special" Thread Style 3
Special thread, extension, rod eye, blank, etc. are also available. To order, specify "Style 3" and give desired dimensions for KK, A, & W. If otherwise special furnish dimensional sketch.

TN and TR Mount – Single Rod End

Styles TN and TR Through Bolt Mount with Pilot Gland or Pilot Cap –
Single Rod End – 20mm to 100mm Bore Size

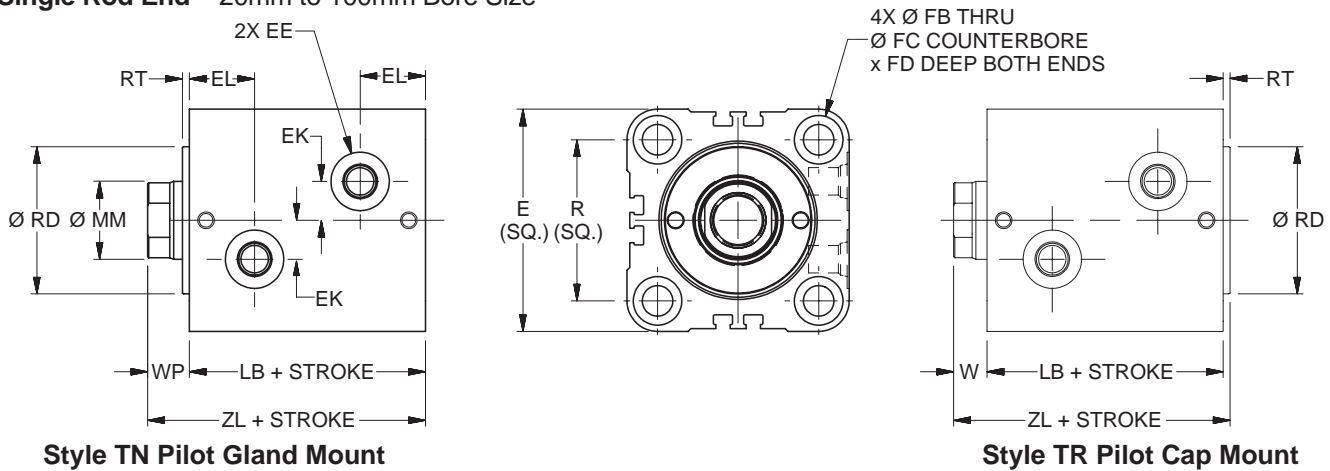

Style TN Pilot Gland Mount

Style TR Pilot Cap Mount

TN and TR Mount Single Rod End – Envelope and Mounting Dimensions

Bore Ø	E	EE			EK	EL	FB Ø	FC Ø	FD	R	RD Ø f9	RT	W	WP	Add Stroke	
		SAE	NPTF	BSP											LB	ZL
20	43 ¹	#2 ²	1/8	G-1/8	6	16.5	5.5	9.5	5.4	30	24	3	8	11	43	54
25	49	#2 ²	1/8	G-1/8	8	17.5	5.5	9.5	5.4	36	27	3	8	11	45	56
32	62	#4	1/4	G-1/4	11	20.5	7	11	6.5	47	36	3	10	13	51	64
40	70	#4	1/4	G-1/4	12	21	9	14	8.6	52	43	3	10	13	55	68
50	80	#4	1/4	G-1/4	14	22.5	11	17.5	10.8	58	53	3	11	14	60	74
63	94	#4	1/4	G-1/4	17	26	13.5	20	13	69	66	3	13	16	67	83
80	114	#6	3/8	G-3/8	20	29.5	16	23	15.2	86	83	3	17	20	78	98
100	138	#6	3/8	G-3/8	25	35	18	26	17.5	106	103	3	26	29	96	125

¹ Port face on 20mm bore is extended 2mm. See port face extension drawing on T Mount page.

² Parker Triple-Lok™ Straight Thread Connector SAE #2 to 1/4" 37° flare can be used when this port thread is required. Contact your local Parker Tube Fitting distributor and specify part number 4-2 F5OX.

TN and TR Mount Single Rod End – Rod Dimensions

Bore Ø	MM Rod Ø	Rod End														Rod Extension Dimensions		
		Style 9M		Style 4M		Style 9A		Style 4A		Style 8A		Style 55M				C	D	NA
		KK	A	KK	A	KK	A	KK	A	CC	A	AD	AE	AF	AM			
20	12	M8x1.25	10	M8x1	14	5/16-24	10	5/16-24	14	3/8-24	16	8	3	6	11	6	10	11
25	14	M10x1.5	12	M10x1.25	16	3/8-24	12	3/8-24	16	1/2-20	18	12	4	8	13	6	12	13
32	18	M12x1.75	15	M12x1.25	18	7/16-20	15	7/16-20	18	9/16-18	25	16	6	10	16	8	15	17
40	22	M16x2	20	M16x1.5	22	5/8-18	20	5/8-18	22	3/4-16	30	20	8	12	20	8	19	21
50	28	M20x2.5	24	M20x1.5	28	3/4-16	24	3/4-16	28	7/8-14	35	24	10	16	25	9	24	27
63	36	M27x3	30	M27x2	36	1-14	30	1-14	36	1 1/4-12	45	28	12	22	33	11	32	35
80	45	M33x3.5	35	M33x2	45	1 1/4-12	35	1 1/4-12	45	1 1/2-12	56	34	14	28	41	13	39	43
100	56	M42x4.5	45	M42x2	56	1 1/2-12	45	1 1/2-12	56	1 3/4-12	70	42	16	35	52	22	48	54

Rod End Dimensions

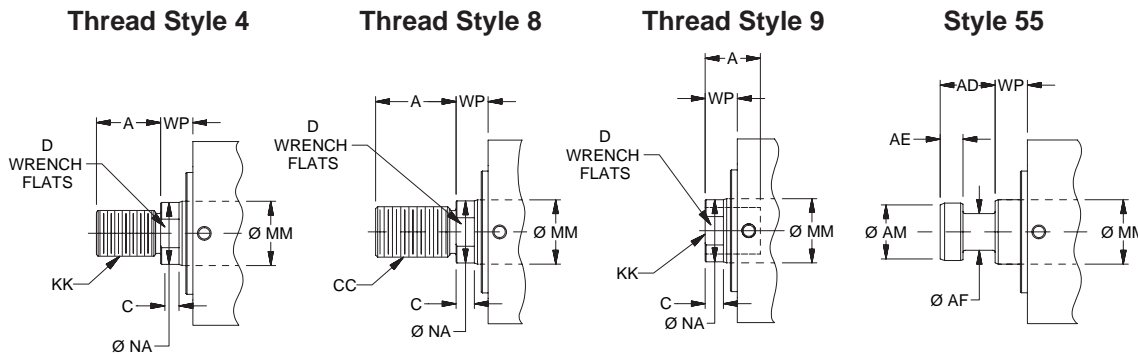

“Special” Thread Style 3

Special thread, extension, rod eye, blank, etc. are also available. To order, specify “Style 3” and give desired dimensions for KK, A, & W (TR Mount) or WP (TN Mount) If otherwise special furnish dimensional sketch.

Style TN Through Bolt Mount with Pilot Gland – Double Rod End – 20mm to 100mm Bore Size

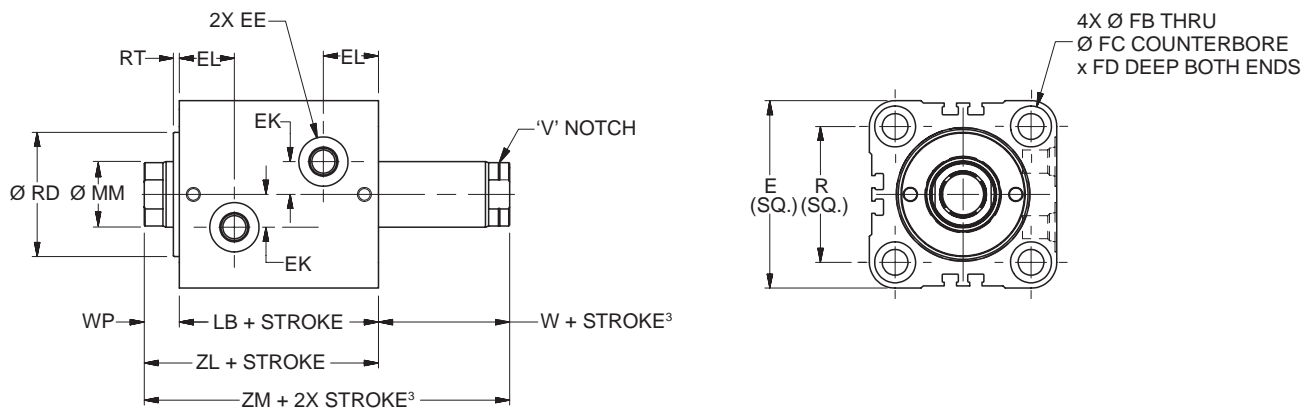

TN Mount Double Rod End – Envelope and Mounting Dimensions

Bore Ø	E	EE			EK	EL	FB Ø	FC Ø	FD	R	RD Ø f9	RT	W ³	WP	Add Stroke		Add 2X Stroke ZM ³
		SAE	NPTF	BSP											LB	ZL	
20	43 ¹	#2 ²	1/8	G-1/8	6	16.5	5.5	9.5	5.4	30	24	3	8	11	43	54	62
25	49	#2 ²	1/8	G-1/8	8	17.5	5.5	9.5	5.4	36	27	3	8	11	45	56	64
32	62	#4	1/4	G-1/4	11	20.5	7	11	6.5	47	36	3	10	13	51	64	74
40	70	#4	1/4	G-1/4	12	21	9	14	8.6	52	43	3	10	13	55	68	78
50	80	#4	1/4	G-1/4	14	22.5	11	17.5	10.8	58	53	3	11	14	60	74	85
63	94	#4	1/4	G-1/4	17	26	13.5	20	13	69	66	3	13	16	67	83	96
80	114	#6	3/8	G-3/8	20	29.5	16	23	15.2	86	83	3	17	20	78	98	115
100	138	#6	3/8	G-3/8	25	35	18	26	17.5	106	103	3	26	29	96	125	151

¹ Port face on 20mm bore is extended 2mm. See port face extension drawing on T Mount page.

² Parker Triple-Lok™ Straight Thread Connector SAE #2 to 1/4" 37° flare can be used when this port thread is required. Contact your local Parker Tube Fitting distributor and specify part number 4-2 F5OX.

³ Minimum 'W + Stroke' on V notch rod side may apply. See minimum rod extension page for details.

TN Mount Double Rod End – Rod Dimensions

Bore Ø	MM Rod Ø	Rod End														Rod Extension Dimensions		
		Style 9M ³		Style 4M		Style 9A ³		Style 4A		Style 8A		Style 55M				C	D	NA
		KK	A	KK	A	KK	A	KK	A	CC	A	AD	AE	AF	AM			
20	12	M8x1.25	10	M8x1	14	5/16-24	10	5/16-24	14	3/8-24	16	8	3	6	11	6	10	11
25	14	M10x1.5	12	M10x1.25	16	3/8-24	12	3/8-24	16	1/2-20	18	12	4	8	13	6	12	13
32	18	M12x1.75	15	M12x1.25	18	7/16-20	15	7/16-20	18	9/16-18	25	16	6	10	16	8	15	17
40	22	M16x2	20	M16x1.5	22	5/8-18	20	5/8-18	22	3/4-16	30	20	8	12	20	8	19	21
50	28	M20x2.5	24	M20x1.5	28	3/4-16	24	3/4-16	28	7/8-14	35	24	10	16	25	9	24	27
63	36	M27x3	30	M27x2	36	1-14	30	1-14	36	1 1/4-12	45	28	12	22	33	11	32	35
80	45	M33x3.5	35	M33x2	45	1 1/4-12	35	1 1/4-12	45	1 1/2-12	56	34	14	28	41	13	39	43
100	56	M42x4.5	45	M42x2	56	1 1/2-12	45	1 1/2-12	56	1 3/4-12	70	42	16	35	52	22	48	54

Rod End Dimensions

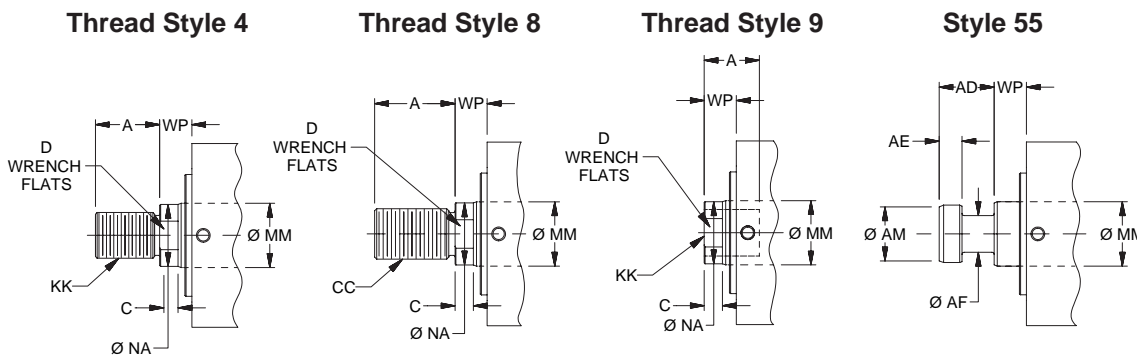

“Special” Thread Style 3
Special thread, extension, rod eye, blank, etc. are also available. To order, specify “Style 3” and give desired dimensions for KK, A, & WP. If otherwise special furnish dimensional sketch.

**Styles J Rectangular Head Flange & H Rectangular Cap Flange Mounts –
Single Rod End – 20mm to 100mm Bore Size**

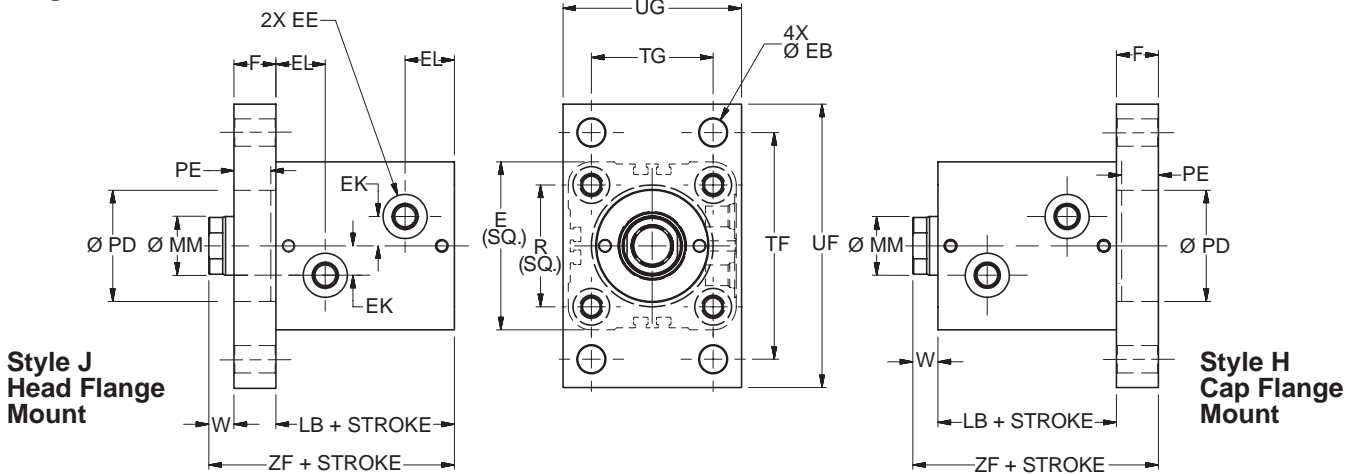

J & H Mounts Single Rod End – Envelope and Mounting Dimensions

Bore Ø	E	EE			EK	EL	F	EB Ø	PD Ø H9	PE	R	TF	TG	UF	UG	W	Add Stroke	
		SAE	NPTF	BSP													LB	ZF
20	43 ¹	#2 ²	1/8	G-1/8	6	16.5	10	5.5	24	7	30	60	30	75	46	8	43	61
25	49	#2 ²	1/8	G-1/8	8	17.5	12	5.5	27	9	36	66	36	80	52	8	45	65
32	62	#4	1/4	G-1/4	11	20.5	12	6.8	36	9	47	80	40	95	62	10	51	73
40	70	#4	1/4	G-1/4	12	21	16	11	43	13	52	96	46	118	70	10	55	81
50	80	#4	1/4	G-1/4	14	22.5	20	13.5	53	17	58	108	58	135	85	11	60	91
63	94	#4	1/4	G-1/4	17	26	20	15	66	17	69	124	65	150	98	13	67	100
80	114	#6	3/8	G-3/8	20	29.5	25	17	83	21	86	154	87	185	118	17	78	120
100	138	#6	3/8	G-3/8	25	35	30	21.5	103	27	106	190	109	230	150	26	96	152

¹ Port face on 20mm bore is extended 2mm. See port face extension drawing on T Mount page.

² Parker Triple-Lok™ Straight Thread Connector SAE #2 to 1/4" 37° flare can be used when this port thread is required. Contact your local Parker Tube Fitting distributor and specify part number 4-2 F5OX.

J & H Mounts Single Rod End – Rod Dimensions

Bore Ø	MM Rod Ø	Rod End														Rod Extension Dimensions		
		Style 9M		Style 4M		Style 9A		Style 4A		Style 8A		Style 55M						
		KK	A	KK	A	KK	A	KK	A	CC	A	AD	AE	AF	AM	C	D	NA
20	12	M8x1.25	10	M8x1	14	5/16-24	10	5/16-24	14	3/8-24	16	8	3	6	11	6	10	11
25	14	M10x1.5	12	M10x1.25	16	3/8-24	12	3/8-24	16	1/2-20	18	12	4	8	13	6	12	13
32	18	M12x1.75	15	M12x1.25	18	7/16-20	15	7/16-20	18	9/16-18	25	16	6	10	16	8	15	17
40	22	M16x2	20	M16x1.5	22	5/8-18	20	5/8-18	22	3/4-16	30	20	8	12	20	8	19	21
50	28	M20x2.5	24	M20x1.5	28	3/4-16	24	3/4-16	28	7/8-14	35	24	10	16	25	9	24	27
63	36	M27x3	30	M27x2	36	1-14	30	1-14	36	1 1/4-12	45	28	12	22	33	11	32	35
80	45	M33x3.5	35	M33x2	45	1 1/4-12	35	1 1/4-12	45	1 1/2-12	56	34	14	28	41	13	39	43
100	56	M42x4.5	45	M42x2	56	1 1/2-12	45	1 1/2-12	56	1 3/4-12	70	42	16	35	52	22	48	54

Rod End Dimensions

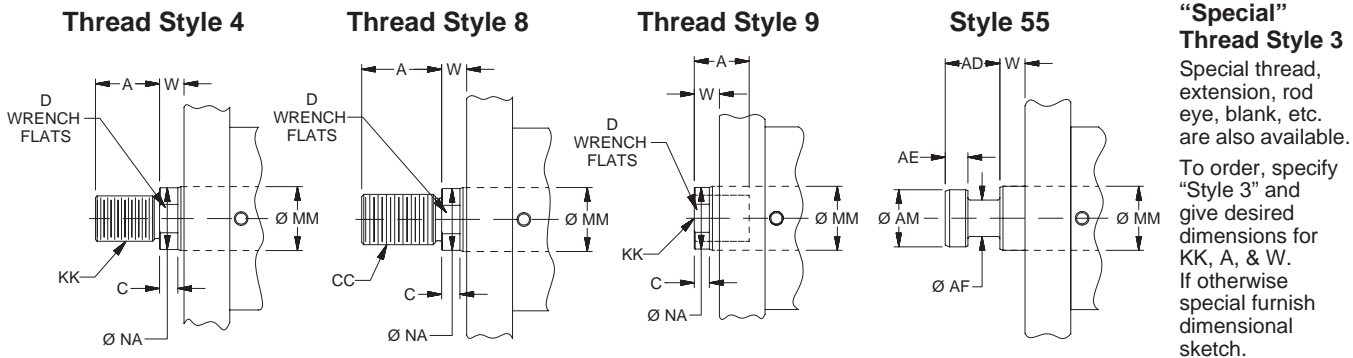

“Special” Thread Style 3
Special thread, extension, rod eye, blank, etc. are also available. To order, specify “Style 3” and give desired dimensions for KK, A, & W. If otherwise special furnish dimensional sketch.

J Mount – Double Rod End

Style J Rectangular Head Flange Mount – Double Rod End – 20mm to 100mm Bore Size

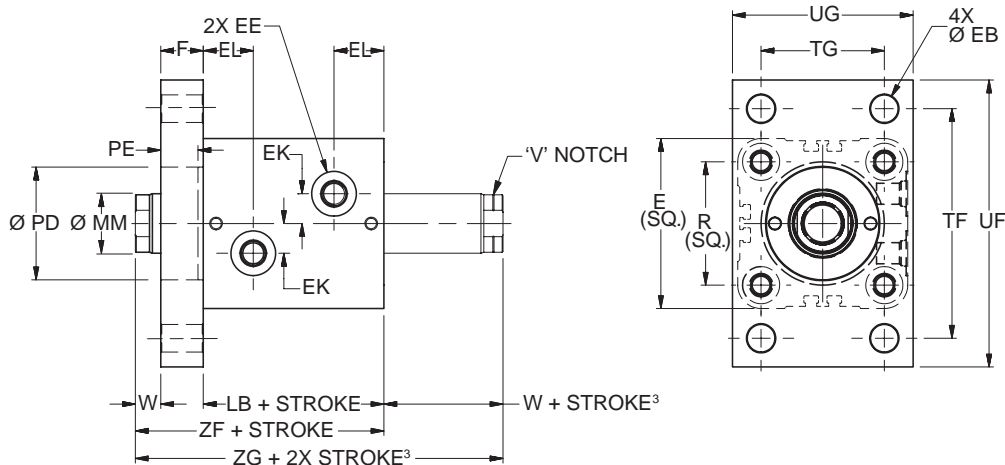

J Mount Double Rod End – Envelope and Mounting Dimensions

Bore Ø	E	EE			EK	EL	F	EB Ø	PD Ø H9	PE	R	TF	TG	UF	UG	W ³	Add Stroke		Add 2X Stroke ZG ³
		SAE	NPTF	BSP													LB	ZF	
20	43 ¹	#2 ²	1/8	G-1/8	6	16.5	10	5.5	24	7	30	60	30	75	46	8	43	61	69
25	49	#2 ²	1/8	G-1/8	8	17.5	12	5.5	27	9	36	66	36	80	52	8	45	65	73
32	62	#4	1/4	G-1/4	11	20.5	12	6.8	36	9	47	80	40	95	62	10	51	73	83
40	70	#4	1/4	G-1/4	12	21	16	11	43	13	52	96	46	118	70	10	55	81	91
50	80	#4	1/4	G-1/4	14	22.5	20	13.5	53	17	58	108	58	135	85	11	60	91	102
63	94	#4	1/4	G-1/4	17	26	20	15	66	17	69	124	65	150	98	13	67	100	113
80	114	#6	3/8	G-3/8	20	29.5	25	17	83	21	86	154	87	185	118	17	78	120	137
100	138	#6	3/8	G-3/8	25	35	30	21.5	103	27	106	190	109	230	150	26	96	152	178

¹ Port face on 20mm bore is extended 2mm. See port face extension drawing on T Mount page.

² Parker Triple-Lok™ Straight Thread Connector SAE #2 to 1/4" 37° flare can be used when this port thread is required. Contact your local Parker Tube Fitting distributor and specify part number 4-2 F5OX.

³ Minimum 'W + Stroke' on V notch rod side may apply. See minimum rod extension page for details.

J Mount Double Rod End – Rod Dimensions

Bore Ø	MM Rod Ø	Rod End														Rod Extension Dimensions		
		Style 9M ³		Style 4M		Style 9A ³		Style 4A		Style 8A		Style 55M				C	D	NA
		KK	A	KK	A	KK	A	KK	A	CC	A	AD	AE	AF	AM			
20	12	M8x1.25	10	M8x1	14	5/16-24	10	5/16-24	14	3/8-24	16	8	3	6	11	6	10	11
25	14	M10x1.5	12	M10x1.25	16	3/8-24	12	3/8-24	16	1/2-20	18	12	4	8	13	6	12	13
32	18	M12x1.75	15	M12x1.25	18	7/16-20	15	7/16-20	18	9/16-18	25	16	6	10	16	8	15	17
40	22	M16x2	20	M16x1.5	22	5/8-18	20	5/8-18	22	3/4-16	30	20	8	12	20	8	19	21
50	28	M20x2.5	24	M20x1.5	28	3/4-16	24	3/4-16	28	7/8-14	35	24	10	16	25	9	24	27
63	36	M27x3	30	M27x2	36	1-14	30	1-14	36	1 1/4-12	45	28	12	22	33	11	32	35
80	45	M33x3.5	35	M33x2	45	1 1/4-12	35	1 1/4-12	45	1 1/2-12	56	34	14	28	41	13	39	43
100	56	M42x4.5	45	M42x2	56	1 1/2-12	45	1 1/2-12	56	1 3/4-12	70	42	16	35	52	22	48	54

Rod End Dimensions

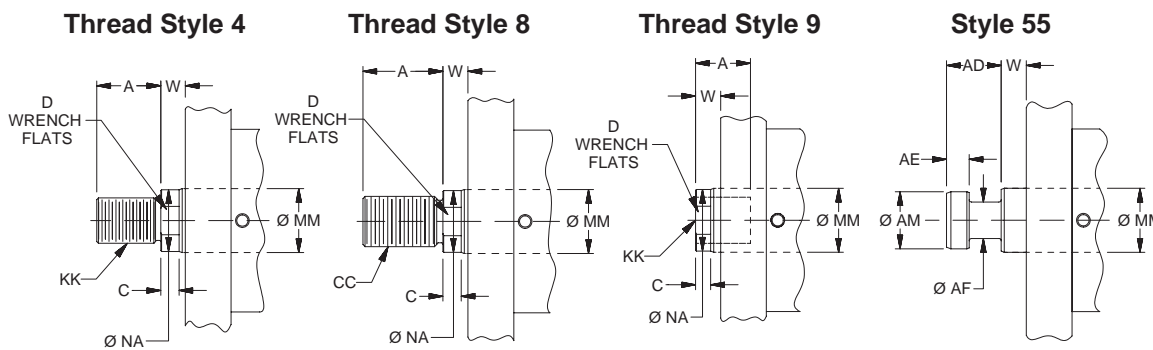

“Special” Thread Style 3
Special thread, extension, rod eye, blank, etc. are also available. To order, specify “Style 3” and give desired dimensions for KK, A, & W. If otherwise special furnish dimensional sketch.

Style CA Side Lug Mount – Single Rod End – 20mm to 100mm Bore Size

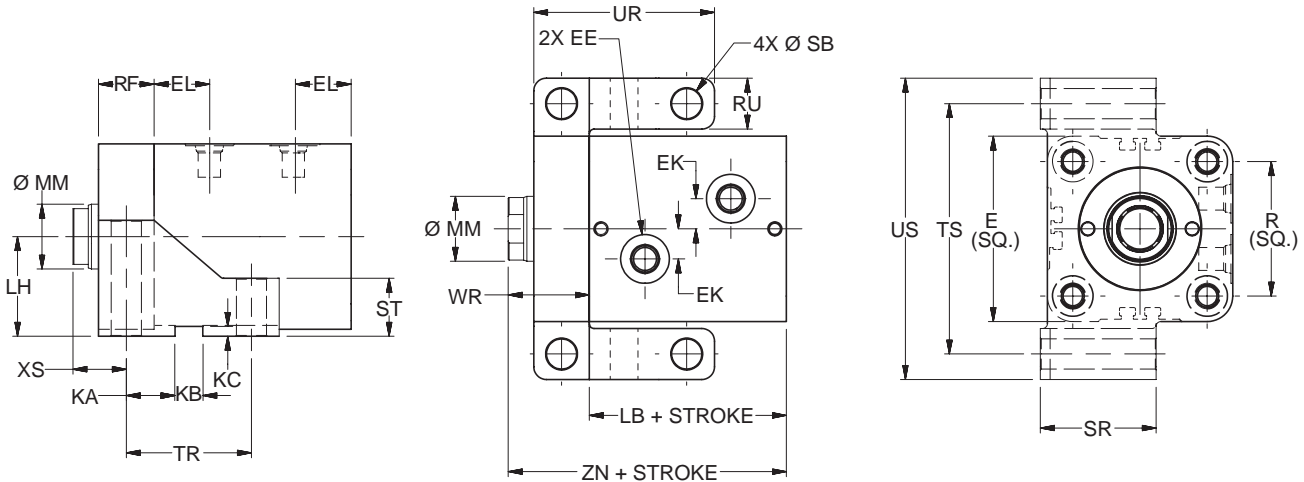

CA Mount Single Rod End – Envelope and Mounting Dimensions

Bore	E	EE			EK	EL	KA	KB	KC	LH	R	RF	RU	SB Ø	SR	ST	TR	TS	UR	US	WR	XS	Add Stroke	
		SAE	NPTF	BSP																			LB	ZN
20	43 ¹	#2 ²	1/8	G-1/8	6	16.5	12	5	2.75	24	30	10	10	5.5	25	10	29	58	39	68	18	13	43	61
25	49	#2 ²	1/8	G-1/8	8	17.5	13.5	6	3.25	27	36	12	12	6.8	30	12	33	66	45	78	20	14	45	65
32	62	#4	1/4	G-1/4	11	20.5	16.5	8	3.75	34	47	16	15	9	35	15	41	82	57	97	26	18	51	77
40	70	#4	1/4	G-1/4	12	21	18.5	10	4.25	38	52	20	18	11	40	20	47	94	67	112	30	20	55	85
50	80	#4	1/4	G-1/4	14	22.5	21	12	4.25	43	58	24	22	13.5	50	25	54	108	78	130	35	23	60	95
63	94	#4	1/4	G-1/4	17	26	25	14	4.75	51	69	28	26	16	60	30	64	128	92	154	41	27	67	108
80	114	#6	3/8	G-3/8	20	29.5	30	16	5.25	61	86	32	30	18	70	35	76	152	108	182	49	33	78	127
100	138	#6	3/8	G-3/8	25	35	36.5	20	6.25	75	106	38	36	22	80	40	93	186	131	222	64	45	96	160

¹ Port face on 20mm bore is extended 2mm. See port face extension drawing on T Mount page.

² Parker Triple-Lok™ Straight Thread Connector SAE #2 to 1/4" 37° flare can be used when this port thread is required. Contact your local Parker Tube Fitting distributor and specify part number 4-2 F5OX.

CA Mount Single Rod End – Rod Dimensions

Bore Ø	MM Rod Ø	Rod End														Rod Extension Dimensions		
		Style 9M		Style 4M		Style 9A		Style 4A		Style 8A		Style 55M						
		KK	A	KK	A	KK	A	KK	A	CC	A	AD	AE	AF	AM	C	D	NA
20	12	M8x1.25	10	M8x1	14	5/16-24	10	5/16-24	14	3/8-24	16	8	3	6	11	6	10	11
25	14	M10x1.5	12	M10x1.25	16	3/8-24	12	3/8-24	16	1/2-20	18	12	4	8	13	6	12	13
32	18	M12x1.75	15	M12x1.25	18	7/16-20	15	7/16-20	18	9/16-18	25	16	6	10	16	8	15	17
40	22	M16x2	20	M16x1.5	22	5/8-18	20	5/8-18	22	3/4-16	30	20	8	12	20	8	19	21
50	28	M20x2.5	24	M20x1.5	28	3/4-16	24	3/4-16	28	7/8-14	35	24	10	16	25	9	24	27
63	36	M27x3	30	M27x2	36	1-14	30	1-14	36	1 1/4-12	45	28	12	22	33	11	32	35
80	45	M33x3.5	35	M33x2	45	1 1/4-12	35	1 1/4-12	45	1 1/2-12	56	34	14	28	41	13	39	43
100	56	M42x4.5	45	M42x2	56	1 1/2-12	45	1 1/2-12	56	1 3/4-12	70	42	16	35	52	22	48	54

Rod End Dimensions

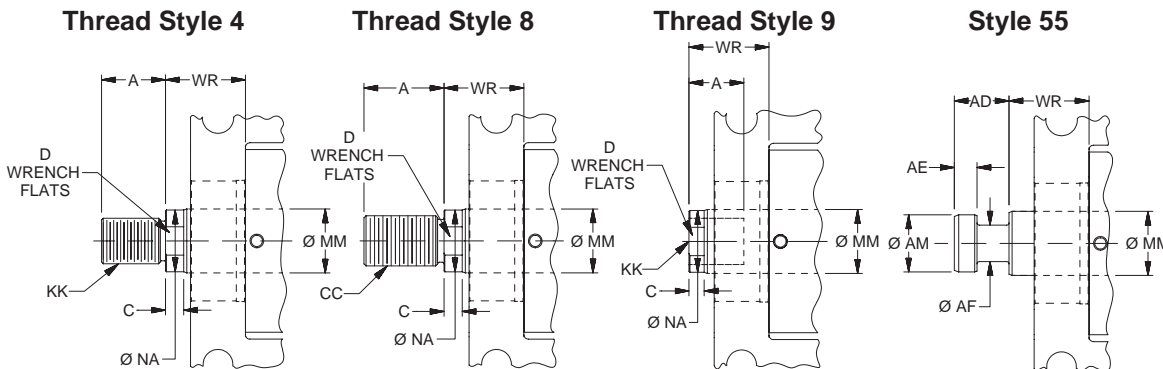

“Special” Thread Style 3
Special thread, extension, rod eye, blank, etc. are also available. To order, specify “Style 3” and give desired dimensions for KK, A, & WR. If otherwise special furnish dimensional sketch.

Style CA Side Lug Mount – Double Rod End – 20mm to 100mm Bore Size

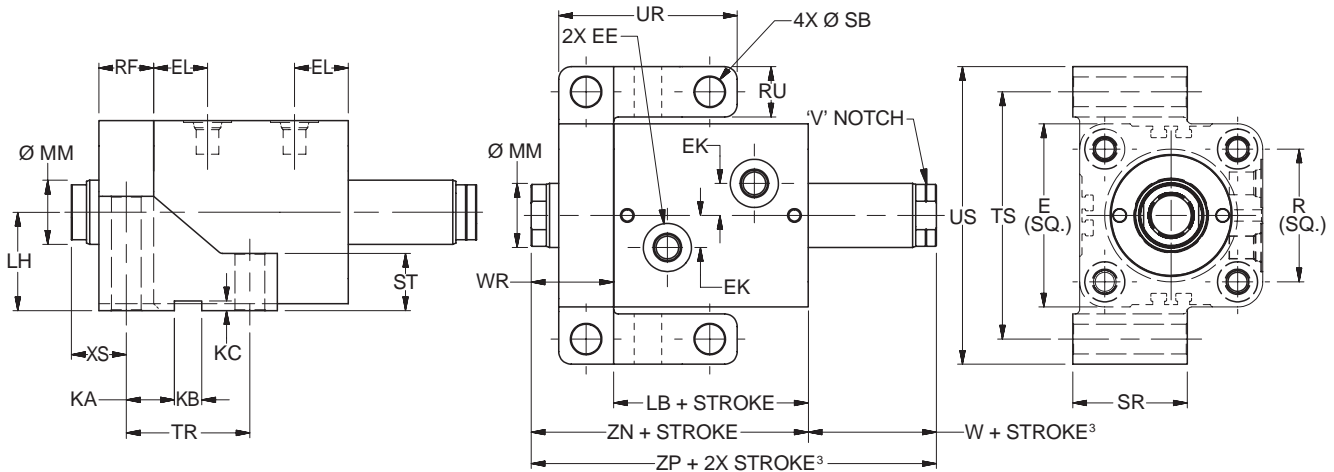

CA Mount Double Rod End – Envelope and Mounting Dimensions

Bore Ø	E	EE			EK	EL	KA	KB	KC	LH	R	RF	RU	SB Ø	SR	ST	TR	TS	UR	US	W ³	WR	XS	Add Stroke			Add 2X Stroke		
		SAE	NPTF	BSP																				LB	ZN	ZP ³	LB	ZN	ZP ³
20	43 ¹	#2 ²	1/8	G-1/8	6	16.5	12	5	2.75	24	30	10	10	5.5	25	10	29	58	39	68	8	18	13	43	61	69			
25	49	#2 ²	1/8	G-1/8	8	17.5	13.5	6	3.25	27	36	12	12	6.8	30	12	33	66	45	78	8	20	14	45	65	73			
32	62	#4	1/4	G-1/4	11	20.5	16.5	8	3.75	34	47	16	15	9	35	15	41	82	57	97	10	26	18	51	77	87			
40	70	#4	1/4	G-1/4	12	21	18.5	10	4.25	38	52	20	18	11	40	20	47	94	67	112	10	30	20	55	85	95			
50	80	#4	1/4	G-1/4	14	22.5	21	12	4.25	43	58	24	22	13.5	50	25	54	108	78	130	11	35	23	60	95	106			
63	94	#4	1/4	G-1/4	17	26	25	14	4.75	51	69	28	26	16	60	30	64	128	92	154	13	41	27	67	108	121			
80	114	#6	3/8	G-3/8	20	29.5	30	16	5.25	61	86	32	30	18	70	35	76	152	108	182	17	49	33	78	127	144			
100	138	#6	3/8	G-3/8	25	35	36.5	20	6.25	75	106	38	36	22	80	40	93	186	131	222	26	64	45	96	160	186			

¹ Port face on 20mm bore is extended 2mm. See port face extension drawing on T Mount page.

² Parker Triple-Lok™ Straight Thread Connector SAE #2 to 1/4" 37° flare can be used when this port thread is required. Contact your local Parker Tube Fitting distributor and specify part number 4-2 F5OX.

³ Minimum 'W + Stroke' on V notch rod side may apply. See minimum rod extension page for details.

CA Mount Double Rod End – Rod Dimensions

Bore Ø	MM Rod Ø	Rod End														Rod Extension Dimensions		
		Style 9M ³		Style 4M		Style 9A ³		Style 4A		Style 8A		Style 55M				C	D	NA
		KK	A	KK	A	KK	A	KK	A	CC	A	AD	AE	AF	AM			
20	12	M8x1.25	10	M8x1	14	5/16-24	10	5/16-24	14	3/8-24	16	8	3	6	11	6	10	11
25	14	M10x1.5	12	M10x1.25	16	3/8-24	12	3/8-24	16	1/2-20	18	12	4	8	13	6	12	13
32	18	M12x1.75	15	M12x1.25	18	7/16-20	15	7/16-20	18	9/16-18	25	16	6	10	16	8	15	17
40	22	M16x2	20	M16x1.5	22	5/8-18	20	5/8-18	22	3/4-16	30	20	8	12	20	8	19	21
50	28	M20x2.5	24	M20x1.5	28	3/4-16	24	3/4-16	28	7/8-14	35	24	10	16	25	9	24	27
63	36	M27x3	30	M27x2	36	1-14	30	1-14	36	1 1/4-12	45	28	12	22	33	11	32	35
80	45	M33x3.5	35	M33x2	45	1 1/4-12	35	1 1/4-12	45	1 1/2-12	56	34	14	28	41	13	39	43
100	56	M42x4.5	45	M42x2	56	1 1/2-12	45	1 1/2-12	56	1 3/4-12	70	42	16	35	52	22	48	54

Rod End Dimensions

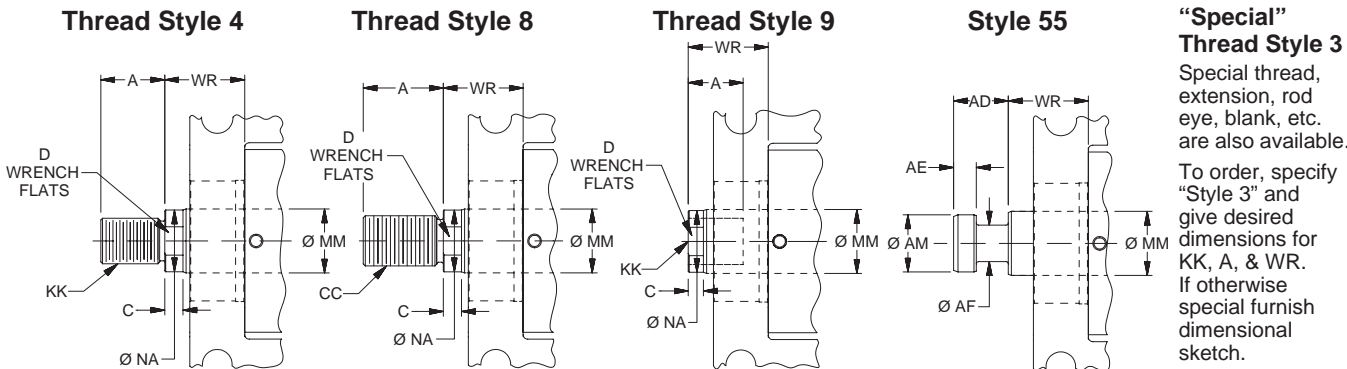

Global Position Sensing Switches



- Low Profile Keeps Switch Within Cylinder Envelope
- Both Reed and Solid State Switch Versions
- Switches Available World-Wide
- Solid State Switches use GMR Technology
- 5 Different Connection Styles
- Allow Position Sensing Anywhere Along Cylinder Stroke
- CE Approved

Global Drop-In Solid State Switches  



Wiring	PNP Switch	NPN Switch	PNP Switch ATEX Certified	PNP Switch High Temperature
3m Flying Leads	P8S-GPFLX	P8S-GNFLX	P8S-GPFLX/EX ¹	P8S-GPFLH ²
10m Flying Leads	P8S-GPFTX	P8S-GNFTX	N/A	N/A
0.3m Lead with 8mm Connector	P8S-GPSHX	P8S-GNSHX		
0.3m Lead with 12mm Connector	P8S-GPMHX	P8S-GNMHX		
1m Lead with 8mm Connector	P8S-GPSCX	P8S-GNSCX		

¹ ATEX switch is supplied with 2m Flying Leads. ² High Temperature switch is not UL Listed.

Specifications

Switch Classification	Standard PNP or NPN	ATEX Certified PNP	High Temperature PNP
Type	Electronic	Electronic	Electronic
Output Function	Normally Open	Normally Open	Normally Open
Switch Output	PNP/NPN	PNP	PNP
Operating Voltage	10 - 30VDC	18 - 30VDC	10 - 30VDC
Continuous Current	100 mA max.	70 mA max.	200 mA max.
Response Sensitivity	28 Gauss min.	28 Gauss min.	25 Gauss
Switching Frequency	5 KHz	1 KHz	10 KHz
Power Consumption	10 mA max.	10 mA max.	15 mA max.
Voltage Drop	2.5 VDC max.	2.5 VDC max.	3.1 VDC max.
Ripple	10% of Operating Voltage	10% of Operating Voltage	15% of Operating Voltage
Hysteresis	1.5 mm max.	1.5 mm max.	1.5 mm max.
Repeatability	0.1 mm max.	0.1 mm max.	0.1 mm max.
EMC	EN 60 947-5-2	EN 60 947-5-2	EN 60 947-5-2
Short-circuit Protection	Yes	Yes	Yes
Power-up Pulse Suppression	Yes	Yes	Yes
Reverse Polarity Protection	Yes	Yes	Yes
Enclosure Rating	IP68	IP68	IP67
Shock and Vibration Stress	30g, 11 ms, 10 to 55Hz, 1 mm	30g, 11 ms, 10 to 55Hz, 1 mm	30g, 11 ms, 10 to 55Hz, 1 mm
Operating Temperature Range	-25°C to +75°C (-13°F to +167°F)	-20°C to +45°C (-4°F to +113°F)	-25°C to +105°C (-13°F to +221°F)
Housing Material	PA 12 Black	PA 12 Black	Aluminum
Connector Cable	PVC	PVC	PUR
Connector	PUR	-	-
Approval for ATEX	-	3D/3G	-

Global solid state switch outputs may be influenced by an external magnetic field. Care must be taken to avoid external magnetic field exposure.

Solid State Switch – Wiring Connection

Flying Lead or 8 mm Connector (shown)

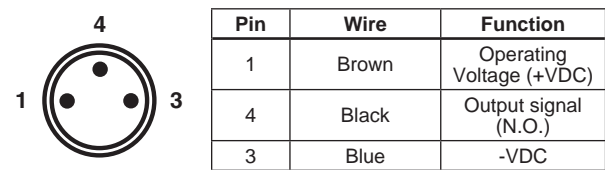

Pin	Wire	Function
1	Brown	Operating Voltage (+VDC)
4	Black	Output signal (N.O.)
3	Blue	-VDC

PNP

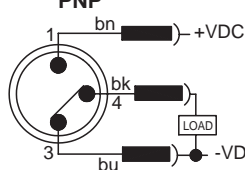

NPN

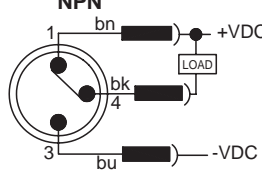

12 mm Connector



Pin	Wire	Function
1	Brown	Operating Voltage (+VDC)
4	Black	Output Signal (N.O.)
2 ¹	White	Not Used
3	Blue	-VDC

¹Pin 2 not present.

PNP

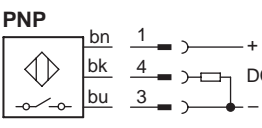

NPN

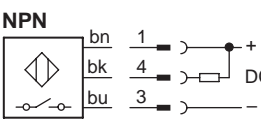

Global Drop-In Reed Switches 

Wiring	Reed Switch
3m Flying Leads	P8S-GRFLX
10m Flying Leads	P8S-GRFTX
0.3m Lead with 8mm Connector	P8S-GRSHX
0.3m Lead with 12mm Connector	P8S-GRMHX
1m Lead with 8mm Connector	P8S-GRSCX

Specifications

Type.....2-Wire Reed
 Output Function.....Normally Open
 Operating Voltage.....10 - 120 VAC¹
 10 - 30 VDC
 Switching Power.....6 W/VA
 Continuous Current.....100 mA max.
 Response Sensitivity.....30 Gauss min.
 Switching Frequency.....400 Hz
 Voltage Drop.....2.5 V max.
 Ripple.....10% of Operating Voltage
 Hysteresis.....1.5 mm max.
 Repeatability.....0.2 mm max.
 EMC.....EN 60 947-5-2
 Reverse Polarity Protection.....Yes
 Enclosure Rating.....IP 68
 Shock and Vibration Stress.....30g, 11 ms, 10 to 55 Hz, 1 mm
 Operating Temperature Range.....-25°C to +75°C (-13°F to 167°F)
 Housing Material.....PA 12, Black
 Connector Cable.....PVC
 Connector.....PUR cable with 8 or
 12 mm connector

Global Reed Switch output may be influenced by external magnetic fields. Care must be taken to avoid external magnetic field exposure.

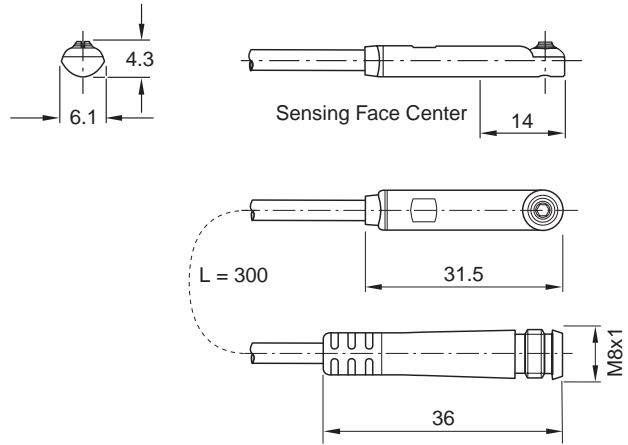

Reed Switch – Wiring Connection

Flying Lead or 8 mm Connector¹

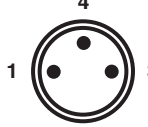

Pin	Wire	Function
1	Brown	Operating Voltage (+V)
4	Black	Not Used
3	Blue	Output Signal (-V or Ground)

¹8mm connector rated for 50 VAC max.

12 mm Connector

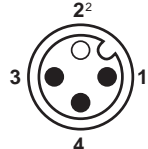

Pin	Wire	Function
1	Brown	Operating Voltage (+V)
2 ²	White	Not Used
3	Blue	Output Signal (-V or Ground)
4	Black	Not Used

²Pin 2 not present.

Circuit for Switching Contact Protection (Inductive Loads)

(Required for proper operation 24V DC)

Put Diode parallel to loads following polarity as shown below.

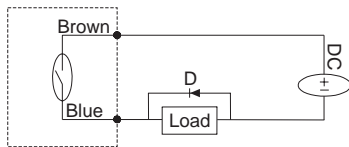

D: Diode: select a Diode with the breakdown voltage and current rating according to the load.

Typical Example—100 Volt, 1 Amp Diode
 CR: Relay coil (under 0.5W coil rating)

(Recommended for longer life 120 VAC)

Put a resistor and capacitor in parallel with the load. Select the resistor and capacitor according to the load.

Typical Example:

CR: Relay coil (under 2W coil rating)
 R: Resistor 1 KΩ - 5 KΩ, 1/4 W
 C: Capacitor 0.1 ΩF, 600 V

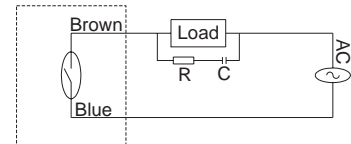

Caution

- Use an ammeter to test reed switch current. Testing devices such as incandescent light bulbs may subject the reed sensor to high in-rush loads.
- **NOTE:** When checking an unpowered reed switch for continuity with a digital ohmmeter the resistance reading will change from infinity to a very large resistance (2 M ohm) when the sensor is activated. This is due to the presence of a diode in the reed switch.
- Anti-magnetic shielding is recommended for reed switches exposed to high external RF or magnetic fields.
- The magnetic field strength of the piston magnet is designed to operate with our switches. Other manufacturers' switches may not operate correctly in conjunction with these magnets.
- Use relay coils for reed switch contact protection.

- The operation of some 120 VAC PLC's (especially some older Allen-Bradley PLC's) can overload the reed switch. The switch may fail to release after the piston magnet has passed. This problem may be corrected by the placement of a 700 to 1K OHM resistor between the switch and the PLC input terminal. Consult the manufacturer of the PLC for appropriate circuit.
- Switches with long wire leads (greater than 15 feet) can cause capacitance build-up and sticking will result. Attach a resistor in series with the reed switches (the resistor should be installed as close as possible to the switches). The resistor should be selected such that R (ohms) >E/0.3.
- Global reed switch outputs may be influenced by an external magnetic field. Care must be taken to avoid external magnetic field exposure.

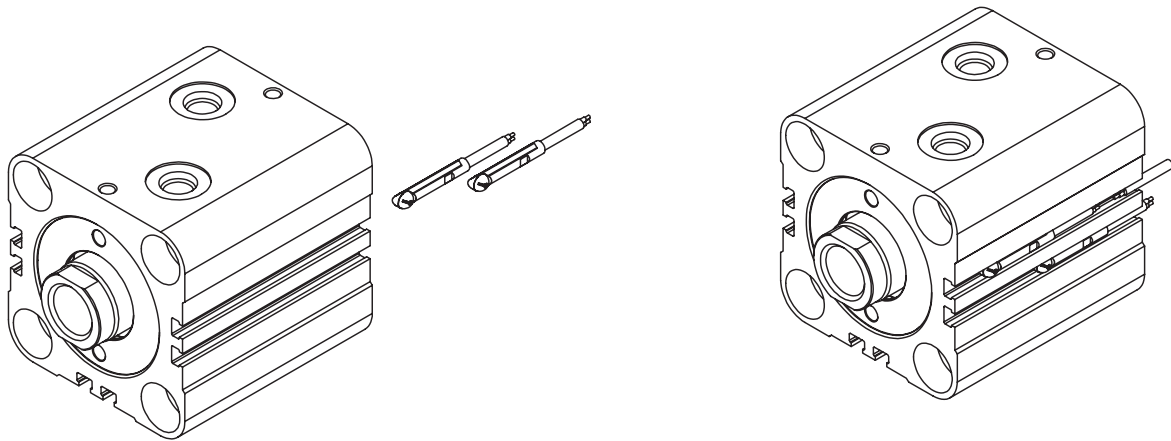

1. Slide the switch into any of the six mounting grooves provided.
2. For end of stroke sensing, position cross hairs of target symbol ⊕ on the switch at the specified distance from the cylinder body end as listed in the table below.
3. Locate the switch as required for intermediate stroke position sensing.
4. Turn the locking screw clockwise to secure the switch in place.

Minimum Stroke for Cylinders with Switches

All Bores	One Switch	Two Switches
	5mm	10mm

Switch Location for End-of-Stroke Sensing

Bore	A	B
20	24	18.5
25	25	19.5
32	28	22.5
40	31	23.5
50	33.5	26
63	37	29.5
80	42.5	35
100	53	42.5

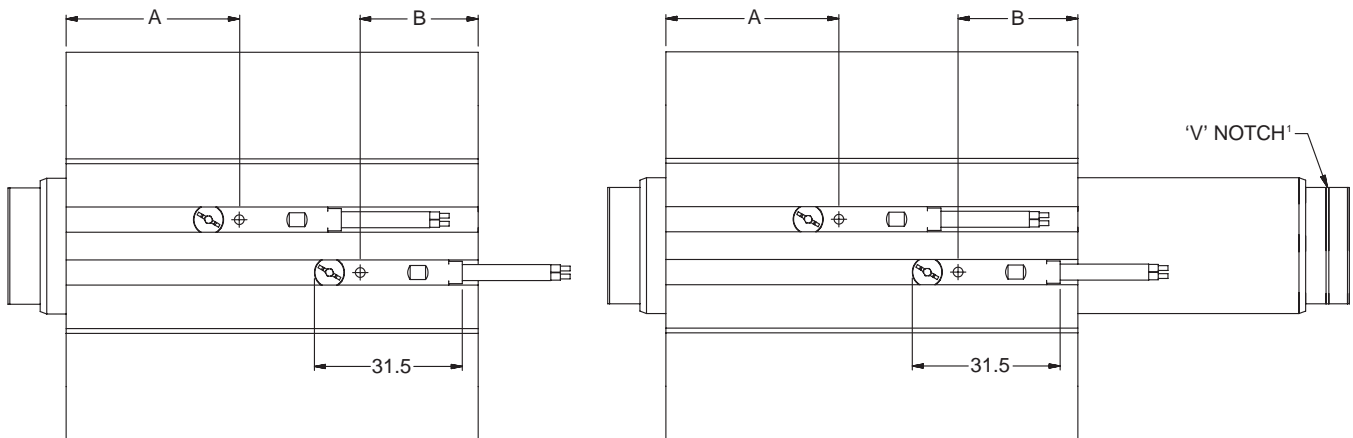

¹ The rod side for switch location 'B', on double rod end cylinders, is identified by a 'V' notch in the 'NA' diameter of rod end styles #4, #8, and #9. The 'V' notch will be in the 'AM' diameter of rod end style #55.

CPS Cylinder Position Sensor – with analog output

The CPS is a linear position sensor that can be used to measure the distance of Series CHE cylinder magnetic piston movement. Bronze cap and gland material (as specified with piston code 5 in the model number) are also required for proper functioning of the CPS. The Cylinder Position Sensor is available in four maximum measuring ranges – 32 mm, 64 mm, 96 mm and 128 mm.

The electrical zero and end points within each range are adjustable using the Teach-In button. Current (4 to 20 mA) and voltage (0 – 10 VDC) analog outputs are selectable through wiring connection and reverse acting of each output is achieved by reversing the zero and end points.

Maximum Sensing Range	Part Number	Wiring
32 mm	CPS-32	0.3m cable with 4-pin 8 mm connector
64 mm	CPS-64	
96 mm	CPS-96	
128 mm	CPS-128	
160 mm	CPS-160	



Specifications

Type.....Electronic
 Supply Voltage..... 15 – 30 VDC
 Analog Output - Current..... 4 – 20 mA
 Analog Output - Voltage..... 0 – 10 VDC
 Max. Load Resistance – Current Output.....500 Ohm
 Max. Load Resistance – Voltage Output.....2 kOhm
 Idle Current typ. 25 mA
 Measuring Range Tolerance.....± 1 mm
 Electrical ConfigurationDC 4-Wire
 Sample Time.....0.5 ms
 Resolution typ.0.05 mm
 Linearity typ.0.3 mm
 Repeat accuracy typ.0.1 mm
 Piston Speed3m/s Maximum
 Ripple 10% of Operating Voltage
 EMC EN 60 947-5-7
 Short Circuit Protection Yes
 Overload Protection..... Yes
 Reverse Polarity Protection..... Yes
 Enclosure RatingIP 67
 Shock and Vibration Stress..... 30g, 11 ms, 10 to 55 Hz, 1 mm
 Operating Temperature Range .. -25°C to +70°C (-4°F to +158°F)
 Housing Material..... PA Strengthened
 Connector Cable..... PUR
 Connector PUR Cable w/8 mm connector

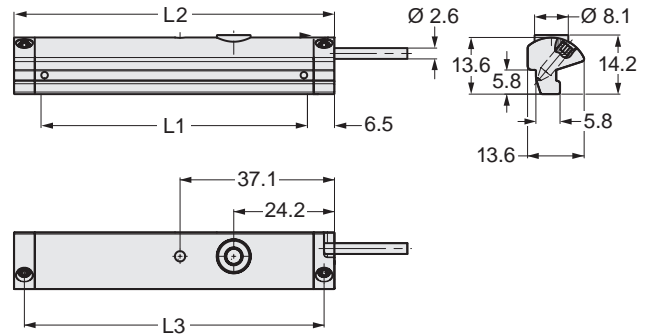

Dimensions

L1 Sensing Range	L2	L3
32	45	40
64	77	72
96	109	104
128	141	136
160	173	168

CPS Wiring Connection
 8 mm
 4-Pin Connector

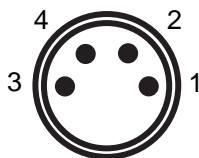

Pin	Wire	Function
1	Brown	Operating Voltage (+VDC)
3	Blue	-VDC
4	Black	0 -10 VDC Output
2	White	4 – 20 mA Output

Operating Instructions

- Read the operating instructions before starting operation.
- Connection, assembly, and settings should be accomplished only by competent technicians.
- This sensor does not qualify as a safety component in accordance with EU machine guidelines.
- Use power source according to IEC/DIN EN 60204-1.
- Do not use ferrite components in the direct environment of the CPS.

Proper Use

The measurement signal is output via analog voltage or current. The yellow LED lights when the piston is within the measurement range (signal strength indicator). The desired Zero Point and End Point of the measurement range can be set precisely via the Teach-In button.

Starting Operation

1. Positioning and securing the sensor:

Connect the sensor to operating voltage (see Specifications and Wiring Connection diagram). Insert the sensor into the cylinder mounting slot from above. Move the piston into the desired Zero Point position. The yellow LED lights when the piston is in the measurement range. Move the sensor along the slot until the LED switches off. Move the sensor back again until the LED lights. Secure the sensor appropriately. The measurement range does not need to be set. If the user does not Teach-In the measurement range, the maximum possible range is used as a default.

2. Teach-In of measurement range (option):

Move the piston into the desired Zero Point position. Press the teach button for 2 seconds; LED blinks (3x/second). Release the Teach-In button; the Zero Point is stored. Set the piston position for the "End Point" of the measurement range. Press the Teach-In button; the "End Point" of the measurement range is stored.

Note: If the Zero Point is external to the measurement range, the Teach-In procedure is aborted and the LED blinks quickly as a result (6x/s). If the Teach-In procedure is not concluded, there is a timeout after 90 seconds; the last taught-in measurement range is active.

3. Check of the taught-in measurement range:

Move the piston and check the set measurement range using the LED. If necessary, correct the desired measurement range via a renewed Teach-In procedure.

4. Reset the measurement range to the default setting:

Press and hold the Teach-In button for at least 5 seconds. The sensor is reset to the default setting (max. measurement range).

Maintenance

Parker CPS magnetic cylinder sensors do not require any maintenance. It is recommend that the screw connections and plug-in connections be checked at regular intervals.

Minimum Stroke

To ensure that both CPS mounting screws engage in the cylinder body, the minimum stroke for each bore and sensor combination must be observed.

Bore Ø	Minimum Stroke				
	CPS-32	CPS-64	CPS-96	CPS-128	CPS-160
20	2	34	N/A	N/A	N/A
25	–	32	64	96	N/A
32	–	26	58	90	122
40	–	22	54	86	118
50	–	17	49	81	113
63	–	10	42	74	106
80	–	–	31	63	95
100	–	–	13	45	77

Cordset for CPS Sensors

The 4-pin, 8 mm threaded connector on this cordset can be used only with CPS Sensors.

Cordset Specifications

- Connector Oil resistant polyurethane body material, PA 6 (Nylon) contact carrier, spacings to VDE 0110 Group C
- Contacts Gold plated brass
- Cord Construction..... Oil resistant black PUR jacket, non-wicking, non-hygroscopic, 300V. Cable end is stripped and tinned.
- Conductors Extra high flex stranding, PVC insulation.
- Temperature -40°C to +90°C (-40°F to +176°F)
- Protection NEMA 6 / IP67
- Cable Length 2m (6.56 ft) or 5m (16.40 ft)

8 mm 4-Pin Connector

Cable Length	Part Number
5 meters	096043T005
2 meters	096043T002

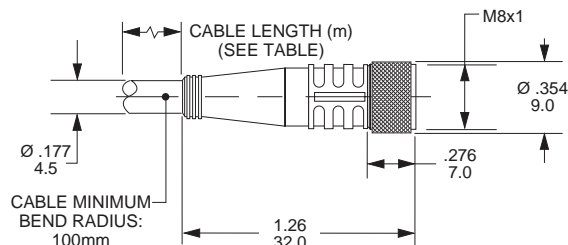

8mm and 12mm Cordset for Global Switches

A female connector is available for all switches with the male 8mm and 12mm quick connect option. The cordsets are available with a right angle or straight connector. Cordset part numbers are listed below.

8mm Cordset

Cable Length	Threaded Connector	Snap On Connector
5 meters	086620T005	086620S005
2 meters	086620T002	086620S002

12mm Cordset

Cable Length	Threaded Connector	Right Angle Connector
5 meters	9126487205	9126487305
2 meters	9126487202	9126487302

Cordset Specifications

- Connector.....Oil resistant polyurethane body material, PA 6 (Nylon) contact carrier, spacings to VDE 0110 Group C, (150 AC/DC)
- ContactsGold plated beryllium copper, machined from solid stock
- Coupling Method.....Snap-Lock or chrome plated brass nut
- Cord Construction Oil resistant black PUR jacket, non-wicking, non-hygroscopic, 300V. Cable end is stripped and tinned.
- Conductors.....Extra high flex stranding, PVC insulation
- Temperature.....-40 to 194°F (-40 to 90°C)
- Protection.....NEMA 1, 3, 4, 6P and IEC 1P67
- Cable Length.....6.56 ft (2m) or 16.4 ft (5m)

8mm Snap-On Straight Connector

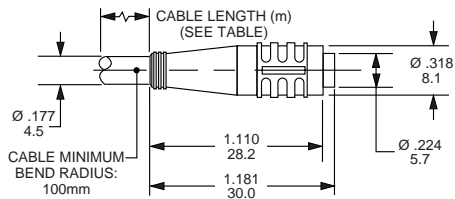

8mm Threaded Straight Connector

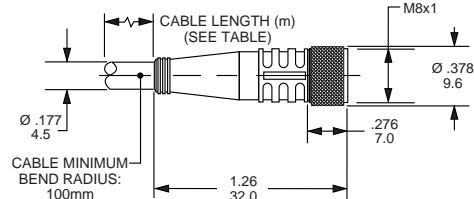

12mm Right Angle Connector

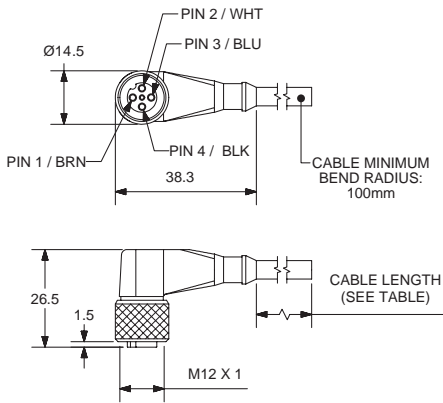

12mm Straight Connector

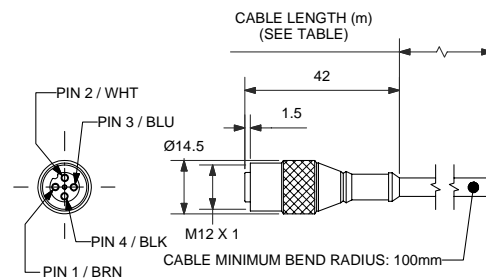

Notes

B

PL-2

PH-2

PH-3

PHX

SHM

CHE/CHD

Notes

Series CHD Cylinder Features

Primary Seal – polyurethane rod seal with multiple sealing edges is self-compensating and self-relieving to withstand pressure variations and conform to mechanical deflection that may occur.

Piston Rod – Medium carbon steel, hard chrome plated and polished.

Ports – SAE O-ring ports are standard.

OPTIONAL PORTS
 NPTF and BSPP ports are also available. Manifold ports are available on mounting styles C & CN.

Secondary Seal – Rod Wiper – wipes clean any oil film adhering to the rod on the extend stroke and cleans the rod on the return stroke.

Bi-directional Piston Seal – Polyurethane seal ring with energizer provides leak-free performance.

Piston Rod End – four standard styles. Special ends available.

Non-Metallic Wear Band – improves resistance to bearing loads.

Rod Gland – nodular iron bearing with RoHS compliant zinc plating for corrosion resistance. Optional pilot gland available at no additional cost.

Cylinder Body – steel with black oxide exterior surface treatment.

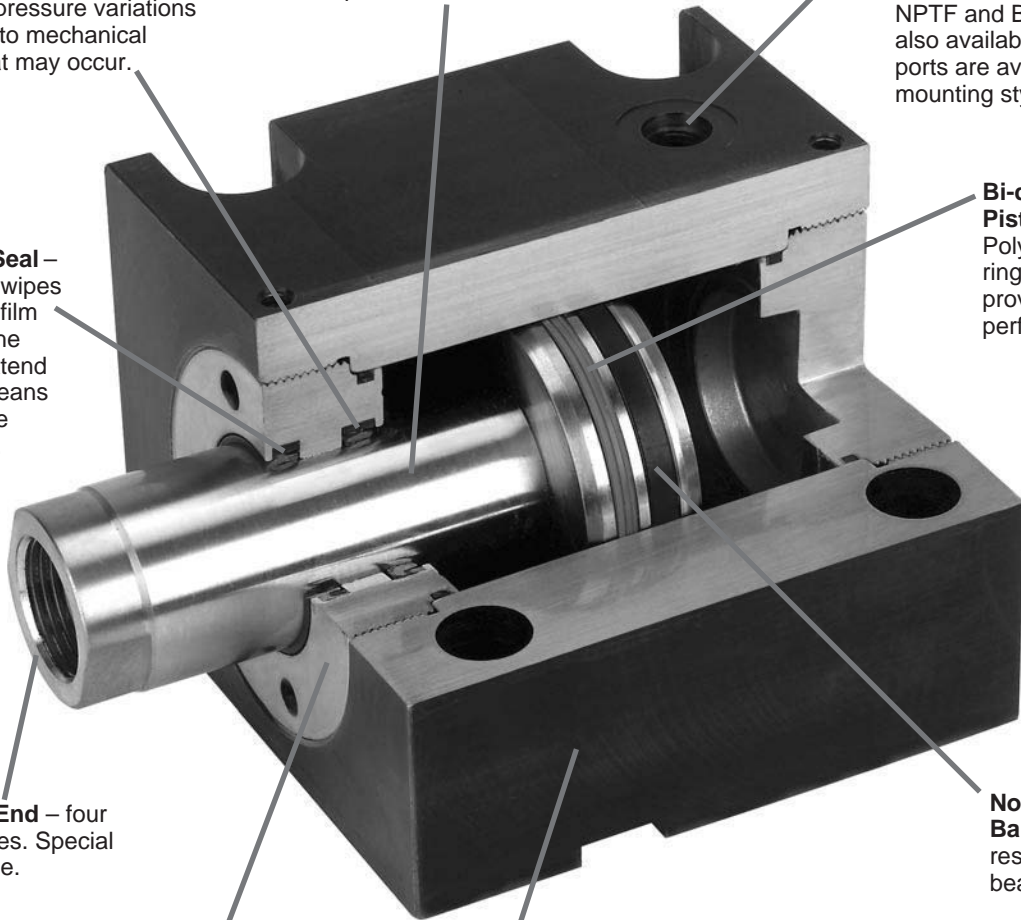

CHD Compact Hydraulic Cylinders... require less mounting space than conventional tie rod cylinders.

Optional Pilot Gland... offers added bearing area to increase service life and also improves alignment of cylinder and load.

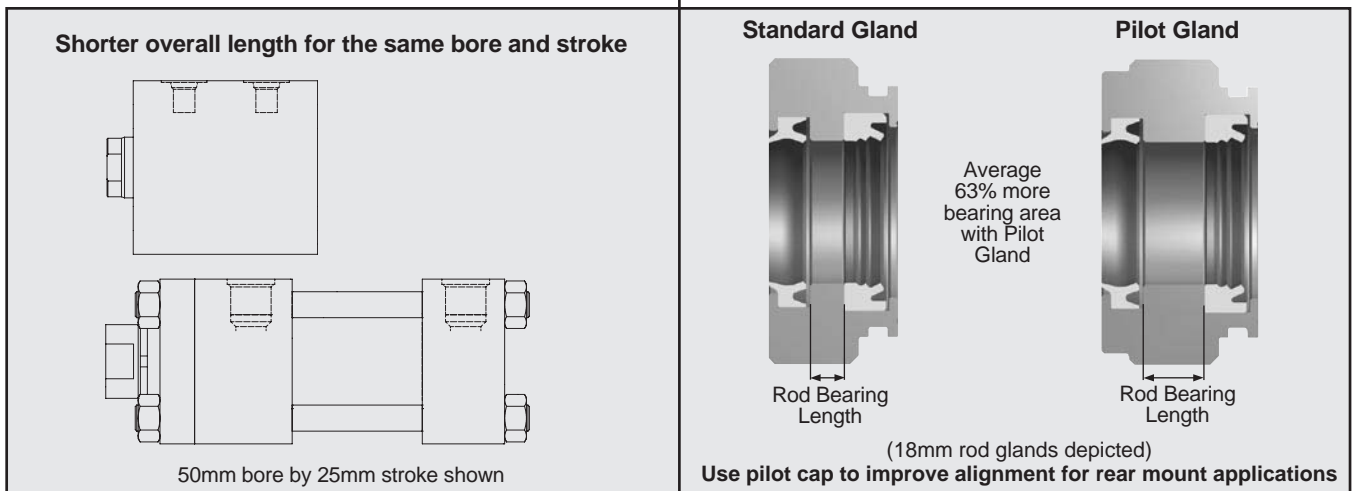

Theoretical Push and Pull Forces

The cylinder output forces are derived from the formula:

$$F = \frac{P \times A}{10000}$$

Where F = Force in kN.

P = Pressure at the cylinder in bar.

A = Effective area of cylinder piston in square mm.

To determine the bore size for the application take the following steps.

Push and Pull Force in kN

Bore Ø	Rod Ø	Operating Direction	Piston Area (mm²)	Operating Pressure (Bar)						
				50	75	100	125	150	175	207
20	12	Push	314	1.57	2.36	3.14	3.93	4.71	5.50	6.50
		Pull	201	1.01	1.51	2.01	2.51	3.02	3.52	4.16
25	14	Push	491	2.45	3.68	4.91	6.14	7.36	8.59	10.2
		Pull	337	1.68	2.53	3.37	4.21	5.05	5.90	6.97
32	18	Push	804	4.02	6.03	8.04	10.1	12.1	14.1	16.6
		Pull	550	2.75	4.12	5.50	6.87	8.25	9.62	11.4
40	22	Push	1,257	6.28	9.42	12.6	15.7	18.8	22.0	26.0
		Pull	877	4.38	6.57	8.8	11.0	13.1	15.3	18.1
50	28	Push	1,963	9.82	14.7	19.6	24.5	29.5	34.4	40.6
		Pull	1,348	6.74	10.1	13.5	16.8	20.2	23.6	27.9
63	36	Push	3,117	15.6	23.4	31.2	39.0	46.8	54.6	64.5
		Pull	2,099	10.5	15.7	21.0	26.2	31.5	36.7	43.5
80	45	Push	5,027	25.1	37.7	50.3	62.8	75.4	88.0	104
		Pull	3,436	17.2	25.8	34.4	43.0	51.5	60.1	71.1

1. Select the Operating Pressure column closest to that desired.

2. In the same column, identify the force required to move the load (always rounding up). If the piston rod is in compression use the 'Push' row and if the piston rod is in tension use the 'Pull' row.

3. In the row to the left is the bore required.

If the cylinder envelope dimensions are too large for the application, increase the operating pressure to the maximum pressure in the table below, if possible, and repeat steps 1 - 3.

**Series CHD
Pressure Rating**

Bore Ø	Maximum Working Pressure in bar
20	207
25	207
32	207
40	207
50	207
63	207
80	207

Equivalents

1 kN = 224.81 pounds force

1 bar = 14.50 psi

1 mm = .03937 inch

1 mm² = .00155 inch²

Cylinder Weights

To determine the weight of a Series CHD cylinder, first select the proper basic zero stroke weight for the mounting required, and then calculate the weight of the

cylinder stroke and add the result to the basic weight. For extra rod extension, use piston rod weights per mm in Table C.

Table A Single Rod End CHD Cylinder Weights in kg.

Bore Ø	Rod Ø	Single Rod Cylinders									
		Basic Weight at Zero Stroke				Per mm Stroke	Basic Weight at Zero Stroke	Per mm Stroke	Basic Weight at Zero Stroke		Per mm Stroke
		T	TN, TR	A, M	AN, AR, MN, MR				C	CN	
20	12	0.57	0.58	0.61	0.62	0.013	0.84	0.013	-	-	-
25	14	0.80	0.81	0.84	0.85	0.016	1.17	0.017	0.71	0.73	0.015
32	18	1.39	1.42	1.45	1.48	0.024	1.92	0.025	1.41	1.43	0.026
40	22	1.87	1.90	1.97	2.01	0.029	2.81	0.031	1.93	1.96	0.033
50	28	2.61	2.67	2.79	2.85	0.036	4.20	0.038	2.82	2.88	0.044
63	36	4.11	4.20	4.34	4.42	0.047	6.11	0.051	4.69	4.78	0.063
80	45	7.19	7.33	7.49	7.62	0.067	10.7	0.072	-	-	-

Table C Piston rod weights in kg.

Rod Ø	Piston Rod Weight per mm
12	0.001
14	0.001
18	0.002
22	0.003
28	0.005
36	0.008
45	0.012

Table B Double Rod End CHD Cylinder Weights in kg.

Bore Ø	Rod Ø	Double Rod Cylinders									
		Basic Weight at Zero Stroke				Per mm Stroke	Basic Weight at Zero Stroke	Per mm Stroke	Basic Weight at Zero Stroke		Per mm Stroke
		T	TN	A, M	AN, MN				C	CN	
20	12	0.60	0.61	0.64	0.65	0.013	0.87	0.014	-	-	-
25	14	0.83	0.85	0.87	0.89	0.017	1.21	0.018	0.75	0.77	0.016
32	18	1.46	1.48	1.52	1.54	0.026	1.98	0.027	1.47	1.50	0.028
40	22	1.97	2.01	2.08	2.11	0.032	2.92	0.034	2.03	2.07	0.036
50	28	2.81	2.87	2.99	3.05	0.041	4.40	0.043	3.02	3.08	0.049
63	36	4.52	4.61	4.75	4.83	0.055	6.53	0.059	5.10	5.19	0.071
80	45	7.99	8.12	8.28	8.42	0.080	11.5	0.085	-	-	-

Equivalent

1 kg = 2.2046 pounds

Model Code & Standard Specifications

Model Ordering Code for CHD

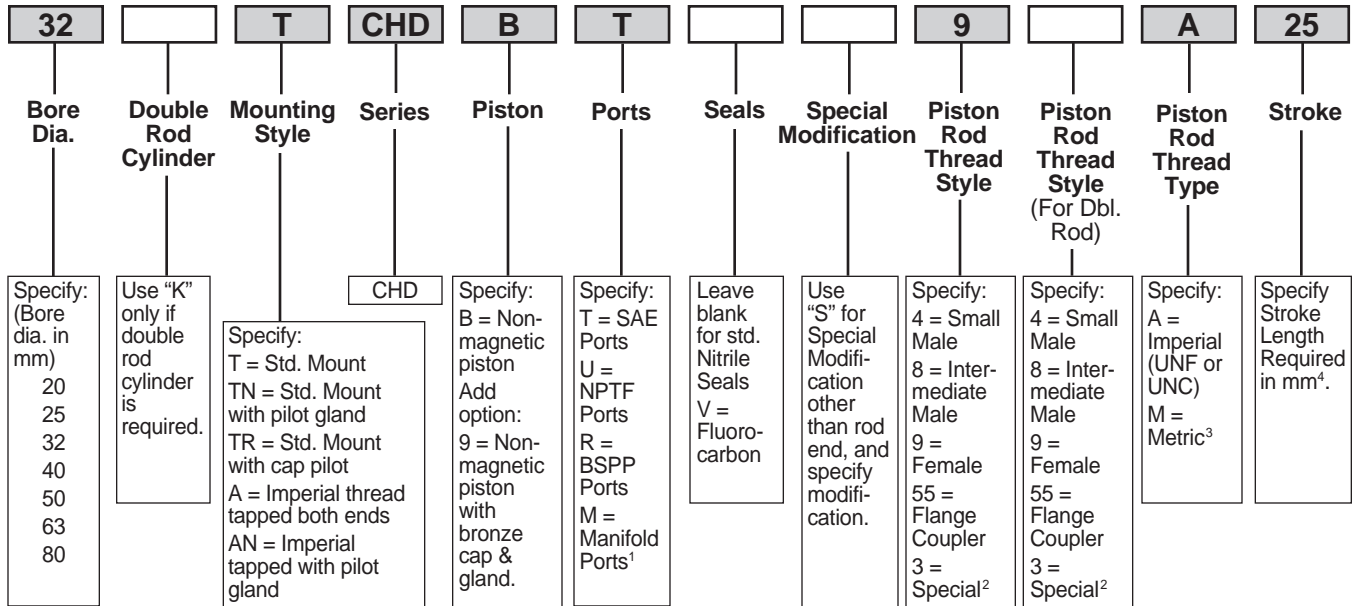

Shaded boxes identify required model number fields.

¹ Manifold ports are only available on Foot Mounting Styles C.

² To order thread style 3, specify "3" and give the desired dimensions for KK, A, and W (or WP depending on mounting) or furnish a dimensioned sketch.

³ Always use M for rod style 55.

⁴ See Maximum Stroke Chart at right.

Maximum Stroke

Bore Ø	Stroke in mm
20	50
25	75
32	100
40	100
50	100
63	100
80	100

Intermediate strokes in 1mm increments are available.

Standard Specifications

- 13 Standard mounting styles
- Bore sizes – 20mm to 80mm
- Piston Rod Diameter – 12mm to 45mm
- Single and double rod construction available
- Strokes up to 100mm depending on bore size (see table above)
- Working pressure up to 207 bar
- Temperature range – -23°C to +121°C (depending on seal class)
- Reference ISO 16656: 2004

Seal Classes	Typical Fluids	Temperature Range
1 – Standard Nitrile & Polyurethane	Hydraulic Oil, MIL-H-5606 Oil	-23°C (-10°F) to +74°C (+165°F)
5 – Optional (At extra cost) Fluorocarbon Seals	High Temperature	-23°C (-10°F) to +121°C (+250°F) Class 5 seals may be operated up to +204°C (+400°F) with reduced service life

Note: Class 5 seals are not suitable for use with Skydrol fluid, but can be used with hydraulic oil if desired.

Style T Through Bolt Mount – Single Rod End – 20mm to 80mm Bore Size

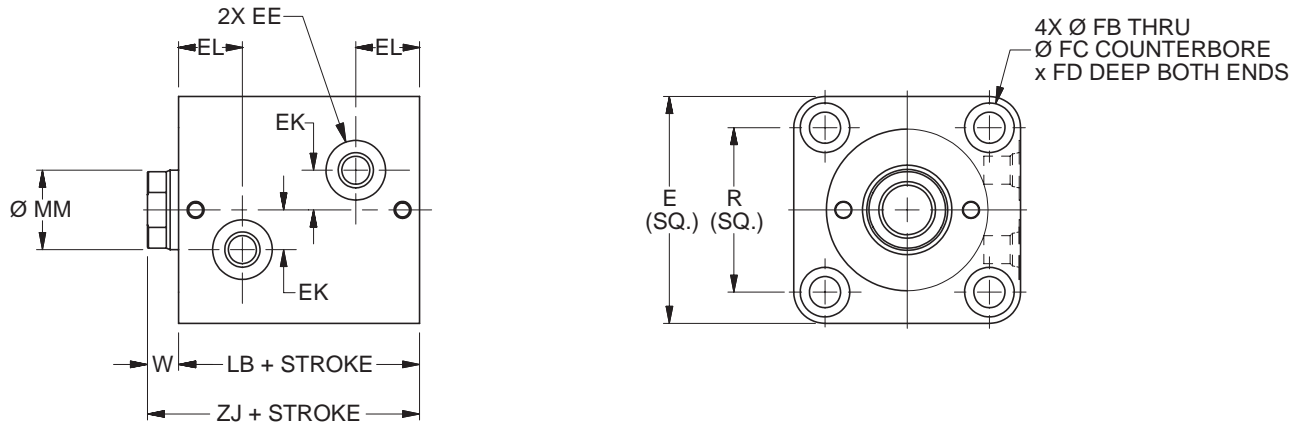

T Mount Single Rod End – Envelope and Mounting Dimensions

Bore Ø	E	EE			EK	EL	FB Ø	FC Ø	FD	R	W	Add Stroke	
		SAE	NPTF	BSP								LB	ZJ
20	44	#2 ¹	1/8	G-1/8	6	16.5	5.5	9.5	5.4	30	8	43	51
25	50	#2 ¹	1/8	G-1/8	8	17.5	5.5	9.5	5.4	36	8	45	53
32	62	#4	1/4	G-1/4	11	20.5	7	11	6.5	47	10	51	61
40	70	#4	1/4	G-1/4	12	21	9	14	8.6	52	10	55	65
50	80	#4	1/4	G-1/4	14	22.5	11	17.5	10.8	58	11	60	71
63	94	#4	1/4	G-1/4	17	26	13.5	20	13	69	13	67	80
80	114	#6	3/8	G-3/8	20	29.5	16	23	15.2	86	17	78	95

¹ Parker Triple-Lok™ Straight Thread Connector SAE #2 to 1/4" 37° flare can be used when this port thread is required. Contact your local Parker Tube Fitting distributor and specify part number 4-2 F5OX.

T Mount Single Rod End – Rod Dimensions

Bore Ø	MM Rod Ø	Rod Thread														Rod Extension Dimensions		
		Style 9M		Style 4M		Style 9A		Style 4A		Style 8A		Style 55M				C	D	NA
		KK	A	KK	A	KK	A	KK	A	CC	A	AD	AE	AF	AM			
20	12	M8x1.25	10	M8x1	14	5/16-24	10	5/16-24	14	3/8-24	16	8	3	6	11	6	10	11
25	14	M10x1.5	12	M10x1.25	16	3/8-24	12	3/8-24	16	1/2-20	18	12	4	8	13	6	12	13
32	18	M12x1.75	15	M12x1.25	18	7/16-20	15	7/16-20	18	9/16-18	25	16	6	10	16	8	15	17
40	22	M16x2	20	M16x1.5	22	5/8-18	20	5/8-18	22	3/4-16	30	20	8	12	20	8	19	21
50	28	M20x2.5	24	M20x1.5	28	3/4-16	24	3/4-16	28	7/8-14	35	24	10	16	25	9	24	27
63	36	M27x3	30	M27x2	36	1-14	30	1-14	36	1 1/4-12	45	28	12	22	33	11	32	35
80	45	M33x3.5	35	M33x2	45	1 1/4-12	35	1 1/4-12	45	1 1/2-12	56	34	14	28	41	13	39	43

Rod End Dimensions

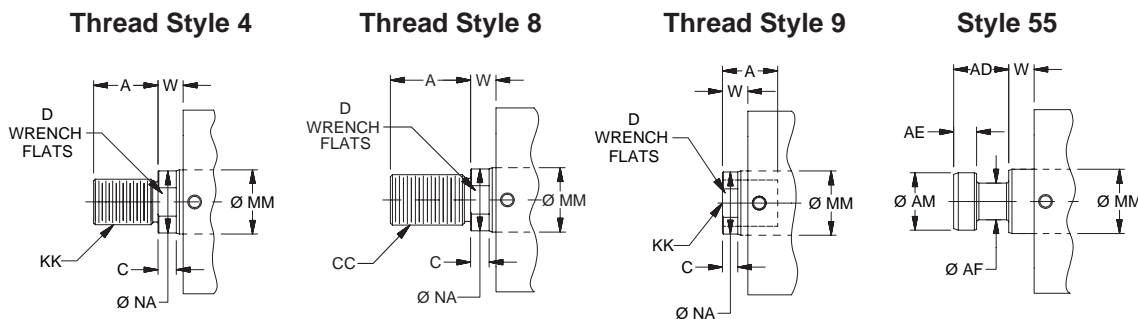

“Special” Thread Style 3
Special thread, extension, rod eye, blank, etc. are also available. To order, specify “Style 3” and give desired dimensions for KK, A, & W. If otherwise special furnish dimensional sketch.

Style T Through Bolt Mount – Double Rod End – 20mm to 80mm Bore Size

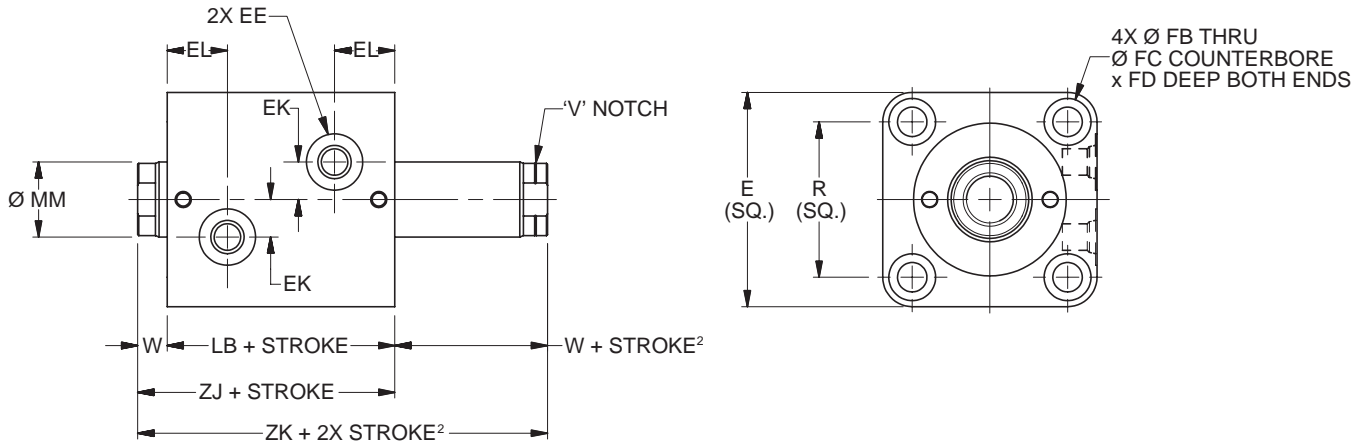

T Mount Double Rod End – Envelope and Mounting Dimensions

Bore Ø	E	EE			EK	EL	FB Ø	FC Ø	FD	R	W ²	Add Stroke		Add 2X Stroke
		SAE	NPTF	BSP								LB	ZJ	ZK ²
20	44	#2 ¹	1/8	G-1/8	6	16.5	5.5	9.5	5.4	30	8	43	51	59
25	50	#2 ¹	1/8	G-1/8	8	17.5	5.5	9.5	5.4	36	8	45	53	61
32	62	#4	1/4	G-1/4	11	20.5	7	11	6.5	47	10	51	61	71
40	70	#4	1/4	G-1/4	12	21	9	14	8.6	52	10	55	65	75
50	80	#4	1/4	G-1/4	14	22.5	11	17.5	10.8	58	11	60	71	82
63	94	#4	1/4	G-1/4	17	26	13.5	20	13	69	13	67	80	93
80	114	#6	3/8	G-3/8	20	29.5	16	23	15.2	86	17	78	95	112

¹ Parker Triple-Lok™ Straight Thread Connector SAE #2 to 1/4" 37° flare can be used when this port thread is required. Contact your local Parker Tube Fitting distributor and specify part number 4-2 F5OX.

² Minimum 'W + Stroke' on V notch rod side may apply. See minimum rod extension page for details.

T Mount Double Rod End – Rod Dimensions

Bore Ø	MM Rod Ø	Rod End														Rod Extension Dimensions		
		Style 9M ²		Style 4M		Style 9A ²		Style 4A		Style 8A		Style 55M				C	D	NA
		KK	A	KK	A	KK	A	KK	A	CC	A	AD	AE	AF	AM			
20	12	M8x1.25	10	M8x1	14	5/16-24	10	5/16-24	14	3/8-24	16	8	3	6	11	6	10	11
25	14	M10x1.5	12	M10x1.25	16	3/8-24	12	3/8-24	16	1/2-20	18	12	4	8	13	6	12	13
32	18	M12x1.75	15	M12x1.25	18	7/16-20	15	7/16-20	18	9/16-18	25	16	6	10	16	8	15	17
40	22	M16x2	20	M16x1.5	22	5/8-18	20	5/8-18	22	3/4-16	30	20	8	12	20	8	19	21
50	28	M20x2.5	24	M20x1.5	28	3/4-16	24	3/4-16	28	7/8-14	35	24	10	16	25	9	24	27
63	36	M27x3	30	M27x2	36	1-14	30	1-14	36	1 1/4-12	45	28	12	22	33	11	32	35
80	45	M33x3.5	35	M33x2	45	1 1/4-12	35	1 1/4-12	45	1 1/2-12	56	34	14	28	41	13	39	43

Rod End Dimensions

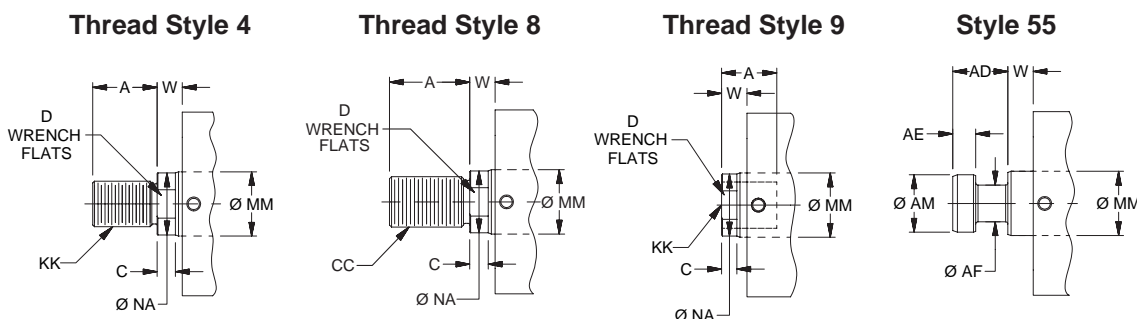

“Special” Thread Style 3
Special thread, extension, rod eye, blank, etc. are also available. To order, specify “Style 3” and give desired dimensions for KK, A, & W. If otherwise special furnish dimensional sketch.

**Styles TN and TR Through Bolt Mount with Pilot Gland or Pilot Cap –
Single Rod End – 20mm to 80mm Bore Size**

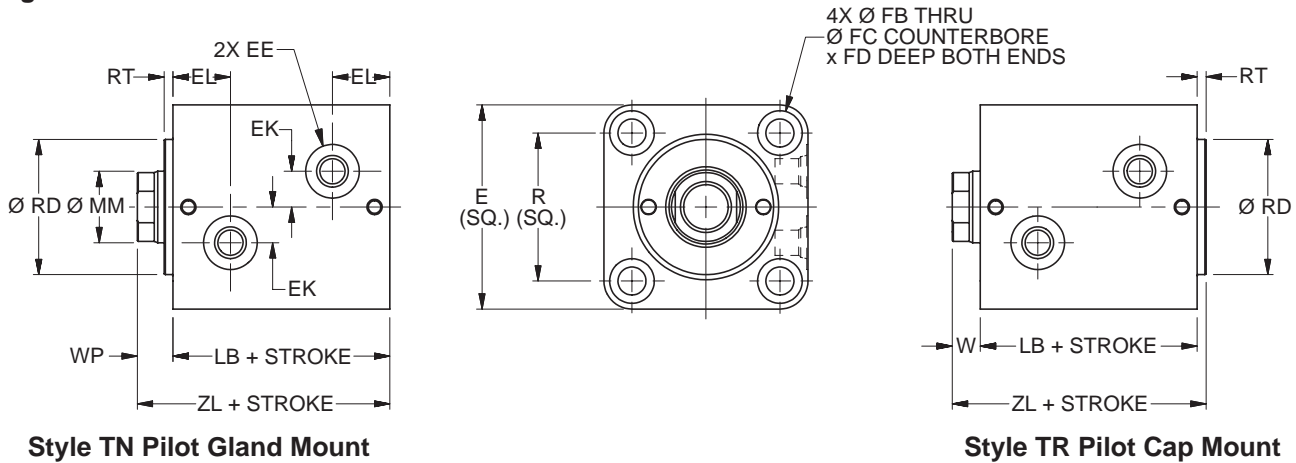

Style TN Pilot Gland Mount

Style TR Pilot Cap Mount

TN and TR Mount Single Rod End – Envelope and Mounting Dimensions

Bore Ø	E	EE			EK	EL	FB Ø	FC Ø	FD	R	RD Ø f9	RT	W	WP	Add Stroke	
		SAE	NPTF	BSP											LB	ZL
20	44	#2 ¹	1/8	G-1/8	6	16.5	5.5	9.5	5.4	30	24	3	8	11	43	54
25	50	#2 ¹	1/8	G-1/8	8	17.5	5.5	9.5	5.4	36	27	3	8	11	45	56
32	62	#4	1/4	G-1/4	11	20.5	7	11	6.5	47	36	3	10	13	51	64
40	70	#4	1/4	G-1/4	12	21	9	14	8.6	52	43	3	10	13	55	68
50	80	#4	1/4	G-1/4	14	22.5	11	17.5	10.8	58	53	3	11	14	60	74
63	94	#4	1/4	G-1/4	17	26	13.5	20	13	69	66	3	13	16	67	83
80	114	#6	3/8	G-3/8	20	29.5	16	23	15.2	86	83	3	17	20	78	98

¹ Parker Triple-Lok™ Straight Thread Connector SAE #2 to 1/4" 37° flare can be used when this port thread is required. Contact your local Parker Tube Fitting distributor and specify part number 4-2 F5OX.

TN and TR Mount Single Rod End – Rod Dimensions

Bore Ø	MM Rod Ø	Rod End														Rod Extension Dimensions		
		Style 9M		Style 4M		Style 9A		Style 4A		Style 8A		Style 55M				C	D	NA
		KK	A	KK	A	KK	A	KK	A	CC	A	AD	AE	AF	AM			
20	12	M8x1.25	10	M8x1	14	5/16-24	10	5/16-24	14	3/8-24	16	8	3	6	11	6	10	11
25	14	M10x1.5	12	M10x1.25	16	3/8-24	12	3/8-24	16	1/2-20	18	12	4	8	13	6	12	13
32	18	M12x1.75	15	M12x1.25	18	7/16-20	15	7/16-20	18	9/16-18	25	16	6	10	16	8	15	17
40	22	M16x2	20	M16x1.5	22	5/8-18	20	5/8-18	22	3/4-16	30	20	8	12	20	8	19	21
50	28	M20x2.5	24	M20x1.5	28	3/4-16	24	3/4-16	28	7/8-14	35	24	10	16	25	9	24	27
63	36	M27x3	30	M27x2	36	1-14	30	1-14	36	1 1/4-12	45	28	12	22	33	11	32	35
80	45	M33x3.5	35	M33x2	45	1 1/4-12	35	1 1/4-12	45	1 1/2-12	56	34	14	28	41	13	39	43

Rod End Dimensions

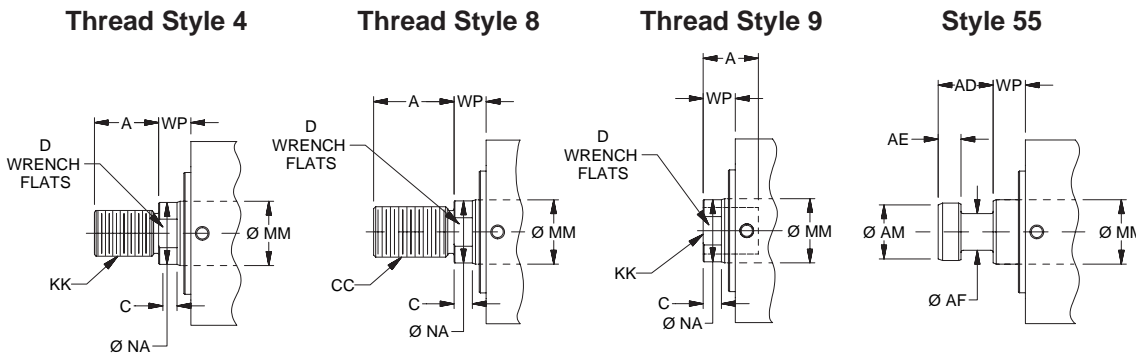

“Special” Thread Style 3
Special thread, extension, rod eye, blank, etc. are also available. To order, specify “Style 3” and give desired dimensions for KK, A, & W (TR Mount) or WP (TN Mount) If otherwise special furnish dimensional sketch.

Style TN Through Bolt Mount with Pilot Gland – Double Rod End – 20mm to 80mm Bore Size

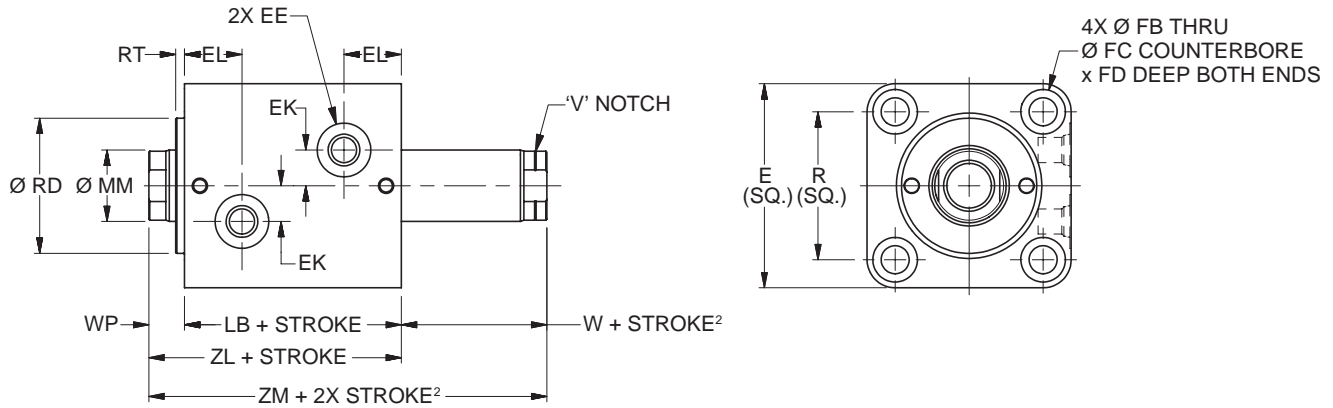

TN Mount Double Rod End – Envelope and Mounting Dimensions

Bore Ø	E	EE			EK	EL	FB Ø	FC Ø	FD	R	RD Ø f9	RT	W ²	WP	Add Stroke		Add 2X Stroke
		SAE	NPTF	BSP											LB	ZL	ZM ²
20	44	#2 ¹	1/8	G-1/8	6	16.5	5.5	9.5	5.4	30	24	3	8	11	43	54	62
25	50	#2 ¹	1/8	G-1/8	8	17.5	5.5	9.5	5.4	36	27	3	8	11	45	56	64
32	62	#4	1/4	G-1/4	11	20.5	7	11	6.5	47	36	3	10	13	51	64	74
40	70	#4	1/4	G-1/4	12	21	9	14	8.6	52	43	3	10	13	55	68	78
50	80	#4	1/4	G-1/4	14	22.5	11	17.5	10.8	58	53	3	11	14	60	74	85
63	94	#4	1/4	G-1/4	17	26	13.5	20	13	69	66	3	13	16	67	83	96
80	114	#6	3/8	G-3/8	20	29.5	16	23	15.2	86	83	3	17	20	78	98	115

¹ Parker Triple-Lok™ Straight Thread Connector SAE #2 to 1/4" 37° flare can be used when this port thread is required. Contact your local Parker Tube Fitting distributor and specify part number 4-2 F5OX.

² Minimum 'W + Stroke' on V notch rod side may apply. See minimum rod extension page for details.

TN Mount Double Rod End – Rod Dimensions

Bore Ø	MM Rod Ø	Rod End														Rod Extension Dimensions		
		Style 9M ²		Style 4M		Style 9A ²		Style 4A		Style 8A		Style 55M				C	D	NA
		KK	A	KK	A	KK	A	KK	A	CC	A	AD	AE	AF	AM			
20	12	M8x1.25	10	M8x1	14	5/16-24	10	5/16-24	14	3/8-24	16	8	3	6	11	6	10	11
25	14	M10x1.5	12	M10x1.25	16	3/8-24	12	3/8-24	16	1/2-20	18	12	4	8	13	6	12	13
32	18	M12x1.75	15	M12x1.25	18	7/16-20	15	7/16-20	18	9/16-18	25	16	6	10	16	8	15	17
40	22	M16x2	20	M16x1.5	22	5/8-18	20	5/8-18	22	3/4-16	30	20	8	12	20	8	19	21
50	28	M20x2.5	24	M20x1.5	28	3/4-16	24	3/4-16	28	7/8-14	35	24	10	16	25	9	24	27
63	36	M27x3	30	M27x2	36	1-14	30	1-14	36	1 1/4-12	45	28	12	22	33	11	32	35
80	45	M33x3.5	35	M33x2	45	1 1/4-12	35	1 1/4-12	45	1 1/2-12	56	34	14	28	41	13	39	43

Rod End Dimensions

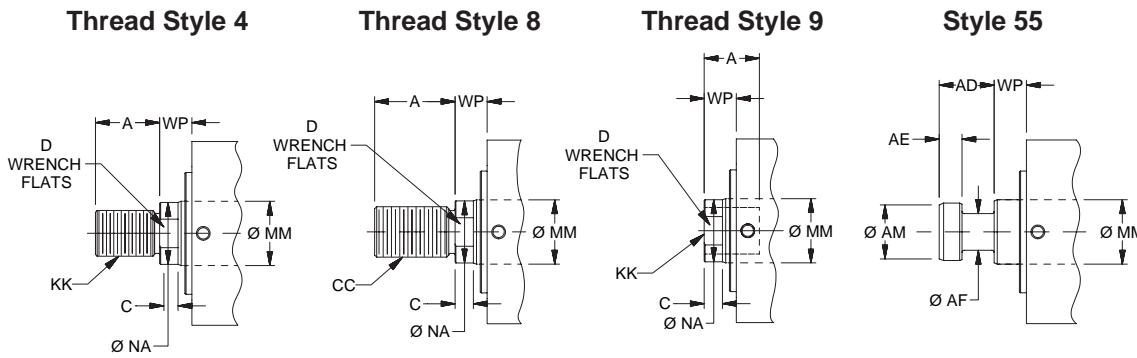

"Special" Thread Style 3
Special thread, rod eye, blank, etc. are also available. To order, specify "Style 3" and give desired dimensions for KK, A, & WP. If otherwise special furnish dimensional sketch.

Style A Imperial Tapped Both Ends Mount – Single Rod End – 20mm to 80mm Bore Size

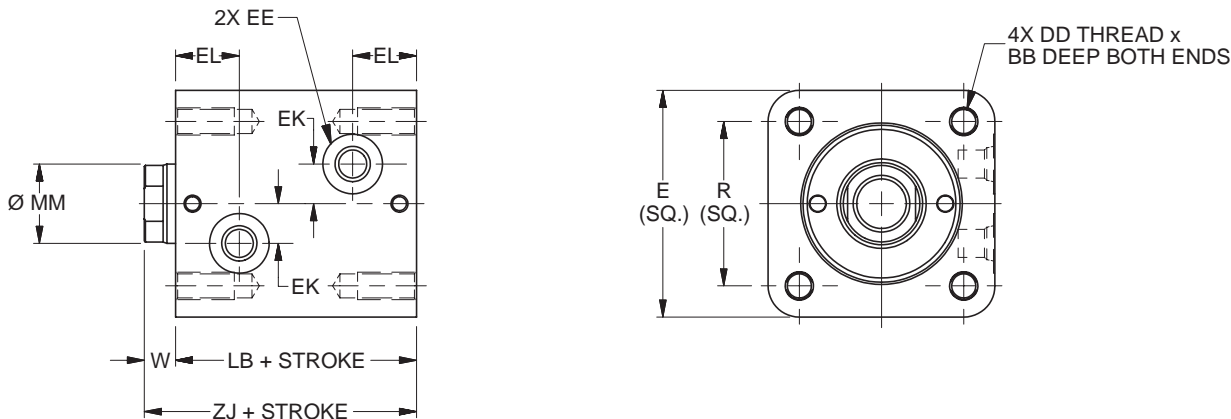

A Mount Single Rod End – Envelope and Mounting Dimensions

Bore Ø	BB	DD	E	EE			EK	EL	R	W	Add Stroke	
				SAE	NPT	BSP					LB	ZJ
20	10.1	10-32 UNF - 2B	44	# 2 ¹	1/8	G-1/8	6	16.5	30	8	43	51
25	10.5	10-32 UNF - 2B	50	# 2 ¹	1/8	G-1/8	8	17.5	36	8	45	53
32	12.5	1/4-28 UNF - 2B	62	# 4	1/4	G-1/4	11	20.5	47	10	51	61
40	16.6	5/16-24 UNF - 2B	70	# 4	1/4	G-1/4	12	21	52	10	55	65
50	20.8	3/8-24 UNF - 2B	80	# 4	1/4	G-1/4	14	22.5	58	11	60	71
63	24.3	1/2-20 UNF - 2B	94	# 4	1/4	G-1/4	17	26	69	13	67	80
80	28.8	5/8-18 UNF - 2B	114	# 6	3/8	G-3/8	20	29.5	86	17	78	95

¹ Parker Triple-Lok™ Straight Thread Connector SAE #2 to 1/4" 37° flare can be used when this port thread is required. Contact your local Parker Tube Fitting distributor and specify part number 4-2 F5OX.

A Mount Single Rod End – Rod Dimensions

Bore Ø	MM Rod Ø	Rod End														Rod Extension Dimensions		
		Style 9M		Style 4M		Style 9A		Style 4A		Style 8A		Style 55M				C	D	NA
		KK	A	KK	A	KK	A	KK	A	CC	A	AD	AE	AF	AM			
20	12	M8x1.25	10	M8x1	14	5/16-24	10	5/16-24	14	3/8-24	16	8	3	6	11	6	10	11
25	14	M10x1.5	12	M10x1.25	16	3/8-24	12	3/8-24	16	1/2-20	18	12	4	8	13	6	12	13
32	18	M12x1.75	15	M12x1.25	18	7/16-20	15	7/16-20	18	9/16-18	25	16	6	10	16	8	15	17
40	22	M16x2	20	M16x1.5	22	5/8-18	20	5/8-18	22	3/4-16	30	20	8	12	20	8	19	21
50	28	M20x2.5	24	M20x1.5	28	3/4-16	24	3/4-16	28	7/8-14	35	24	10	16	25	9	24	27
63	36	M27x3	30	M27x2	36	1-14	30	1-14	36	1 1/4-12	45	28	12	22	33	11	32	35
80	45	M33x3.5	35	M33x2	45	1 1/4-12	35	1 1/4-12	45	1 1/2-12	56	34	14	28	41	13	39	43

Rod End Dimensions

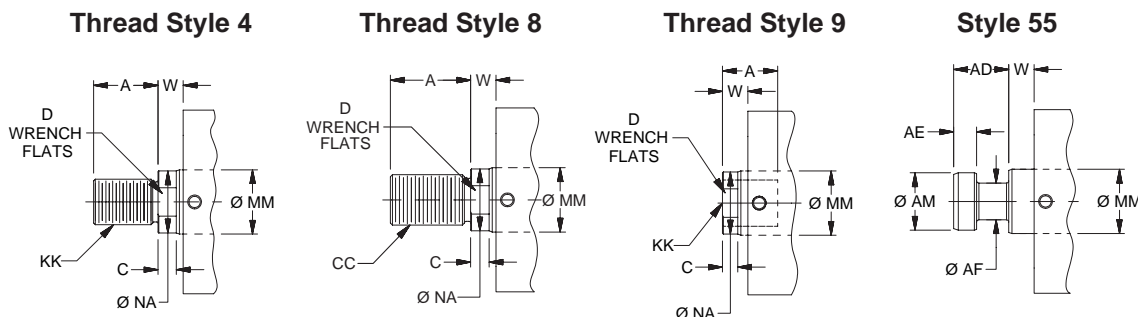

“Special” Thread Style 3
Special thread, extension, rod eye, blank, etc. are also available. To order, specify “Style 3” and give desired dimensions for KK, A, & W. If otherwise special furnish dimensional sketch.

Style A Imperial Tapped Both Ends Mount – Double Rod End – 20mm to 80mm Bore Size

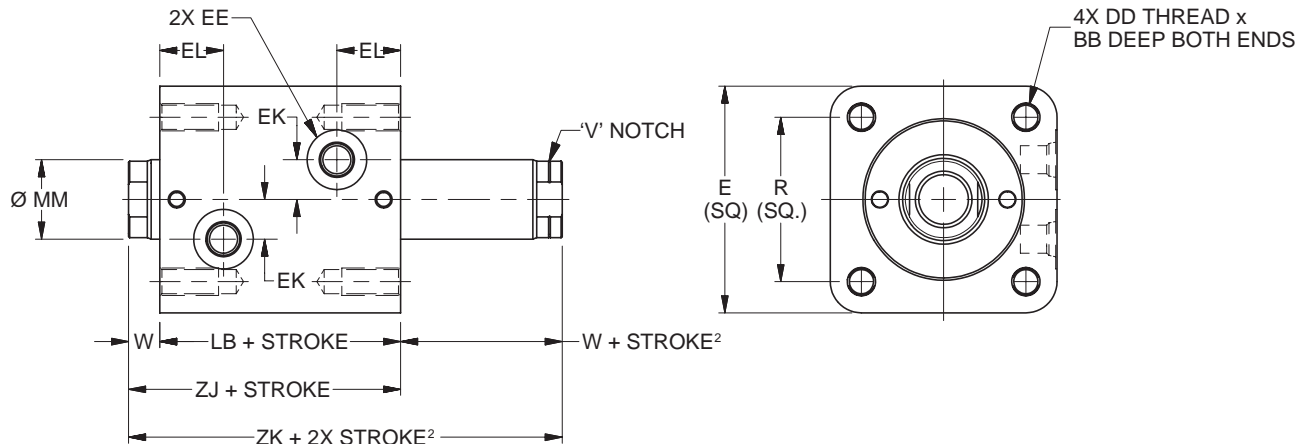

A Mount Double Rod End – Envelope and Mounting Dimensions

Bore Ø	BB	DD	E	EE			EK	EL	R	W ²	Add Stroke		Add 2X Stroke ZK ²
				SAE	NPT	BSP					LB	ZJ	
20	10.1	10-32 UNF - 2B	44	# 2 ¹	1/8	G-1/8	6	16.5	30	8	43	51	59
25	10.5	10-32 UNF - 2B	50	# 2 ¹	1/8	G-1/8	8	17.5	36	8	45	53	61
32	12.5	1/4-28 UNF - 2B	62	# 4	1/4	G-1/4	11	20.5	47	10	51	61	71
40	16.6	5/16-24 UNF - 2B	70	# 4	1/4	G-1/4	12	21	52	10	55	65	75
50	20.8	3/8-24 UNF - 2B	80	# 4	1/4	G-1/4	14	22.5	58	11	60	71	82
63	24.3	1/2-20 UNF - 2B	94	# 4	1/4	G-1/4	17	26	69	13	67	80	93
80	28.8	5/8-18 UNF - 2B	114	# 6	3/8	G-3/8	20	29.5	86	17	78	95	112

¹ Parker Triple-Lok™ Straight Thread Connector SAE #2 to 1/4" 37° flare can be used when this port thread is required. Contact your local Parker Tube Fitting distributor and specify part number 4-2 F5OX.

² Minimum 'W + Stroke' on V notch rod side may apply. See minimum rod extension page for details.

A Mount Double Rod End – Rod Dimensions

Bore Ø	MM Rod Ø	Rod End														Rod Extension Dimensions		
		Style 9M ²		Style 4M		Style 9A ²		Style 4A		Style 8A		Style 55M				C	D	NA
		KK	A	KK	A	KK	A	KK	A	CC	A	AD	AE	AF	AM			
20	12	M8x1.25	10	M8x1	14	5/16-24	10	5/16-24	14	3/8-24	16	8	3	6	11	6	10	11
25	14	M10x1.5	12	M10x1.25	16	3/8-24	12	3/8-24	16	1/2-20	18	12	4	8	13	6	12	13
32	18	M12x1.75	15	M12x1.25	18	7/16-20	15	7/16-20	18	9/16-18	25	16	6	10	16	8	15	17
40	22	M16x2	20	M16x1.5	22	5/8-18	20	5/8-18	22	3/4-16	30	20	8	12	20	8	19	21
50	28	M20x2.5	24	M20x1.5	28	3/4-16	24	3/4-16	28	7/8-14	35	24	10	16	25	9	24	27
63	36	M27x3	30	M27x2	36	1-14	30	1-14	36	1 1/4-12	45	28	12	22	33	11	32	35
80	45	M33x3.5	35	M33x2	45	1 1/4-12	35	1 1/4-12	45	1 1/2-12	56	34	14	28	41	13	39	43

Rod End Dimensions

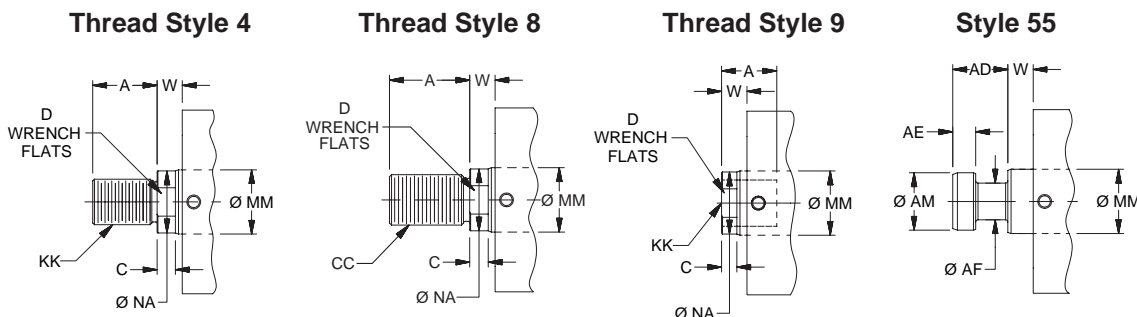

“Special” Thread Style 3
Special thread, extension, rod eye, blank, etc. are also available. To order, specify “Style 3” and give desired dimensions for KK, A, & W. If otherwise special furnish dimensional sketch.

**Styles AN and AR Imperial Tapped Both Ends Mounts with Pilot Gland or Pilot Cap –
Single Rod End – 20mm to 80mm Bore Size**

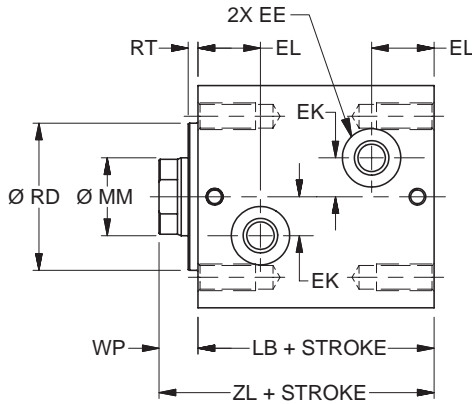

Style AN Imperial Tapped Both Ends Mount with Pilot Gland

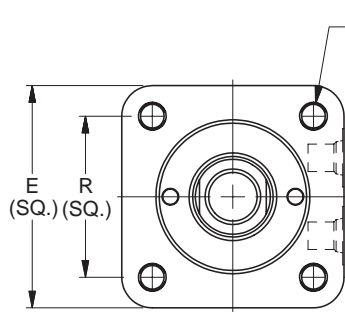

4X DD THREAD x BB DEEP BOTH ENDS

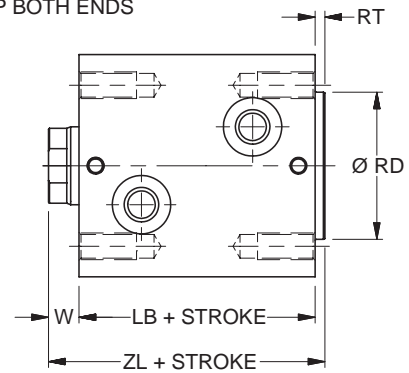

Style AR Imperial Tapped Both Ends Mount with Pilot Cap

AN and AR Mount Single Rod End – Envelope and Mounting Dimensions

Bore Ø	BB	DD	E	EE			EK	EL	R	RD Ø f9	RT	W	WP	Add Stroke	
				SAE	NPT	BSP								LB	ZL
20	10.1	10-32 UNF - 2B	44	# 2 ¹	1/8	G-1/8	6	16.5	30	24	3	8	11	43	54
25	10.5	10-32 UNF - 2B	50	# 2 ¹	1/8	G-1/8	8	17.5	36	27	3	8	11	45	56
32	12.5	1/4-28 UNF - 2B	62	# 4	1/4	G-1/4	11	20.5	47	36	3	10	13	51	64
40	16.6	5/16-24 UNF - 2B	70	# 4	1/4	G-1/4	12	21	52	43	3	10	13	55	68
50	20.8	3/8-24 UNF - 2B	80	# 4	1/4	G-1/4	14	22.5	58	53	3	11	14	60	74
63	24.3	1/2-20 UNF - 2B	94	# 4	1/4	G-1/4	17	26	69	66	3	13	16	67	83
80	28.8	5/8-18 UNF - 2B	114	# 6	3/8	G-3/8	20	29.5	86	83	3	17	20	78	98

¹ Parker Triple-Lok™ Straight Thread Connector SAE #2 to 1/4" 37° flare can be used when this port thread is required. Contact your local Parker Tube Fitting distributor and specify part number 4-2 F5OX.

AN and AR Mount Single Rod End – Rod Dimensions

Bore Ø	MM Rod Ø	Rod End														Rod Extension Dimensions		
		Style 9M		Style 4M		Style 9A		Style 4A		Style 8A		Style 55M				C	D	NA
		KK	A	KK	A	KK	A	KK	A	CC	A	AD	AE	AF	AM			
20	12	M8x1.25	10	M8x1	14	5/16-24	10	5/16-24	14	3/8-24	16	8	3	6	11	6	10	11
25	14	M10x1.5	12	M10x1.25	16	3/8-24	12	3/8-24	16	1/2-20	18	12	4	8	13	6	12	13
32	18	M12x1.75	15	M12x1.25	18	7/16-20	15	7/16-20	18	9/16-18	25	16	6	10	16	8	15	17
40	22	M16x2	20	M16x1.5	22	5/8-18	20	5/8-18	22	3/4-16	30	20	8	12	20	8	19	21
50	28	M20x2.5	24	M20x1.5	28	3/4-16	24	3/4-16	28	7/8-14	35	24	10	16	25	9	24	27
63	36	M27x3	30	M27x2	36	1-14	30	1-14	36	1 1/4-12	45	28	12	22	33	11	32	35
80	45	M33x3.5	35	M33x2	45	1 1/4-12	35	1 1/4-12	45	1 1/2-12	56	34	14	28	41	13	39	43

Rod End Dimensions

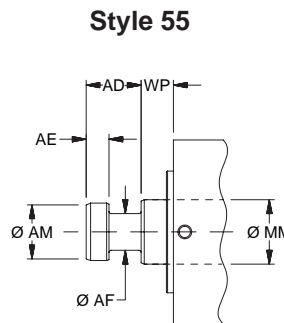
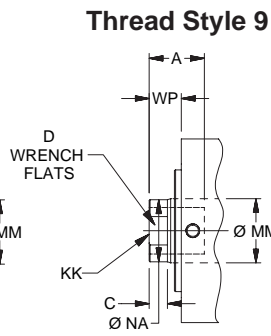
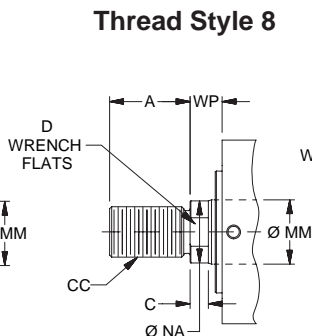
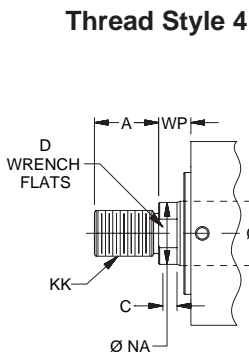

“Special” Thread Style 3
Special thread, extension, rod eye, blank, etc. are also available. To order, specify “Style 3” and give desired dimensions for KK, A, & W (AR Mount) or WP (AN Mount) If otherwise special furnish dimensional sketch.

Style AN Imperial Tapped Both Ends Mount with Pilot Gland – Double Rod End – 20mm to 80mm Bore Size

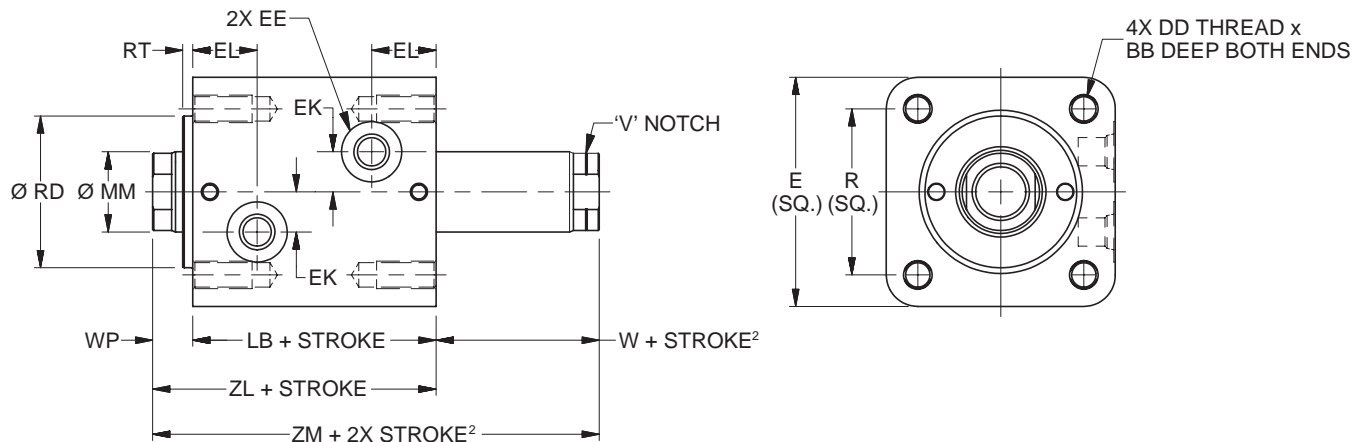

AN Mount Double Rod End – Envelope and Mounting Dimensions

Bore Ø	BB	DD	E	EE			EK	EL	R	RD Ø f9	RT	W ²	WP	Add Stroke		Add 2X Stroke ZM ²
				SAE	NPTF	BSP								LB	ZL	
20	10.1	10-32 UNF - 2B	44	# 2 ¹	1/8	G-1/8	6	16.5	30	24	3	8	11	43	54	62
25	10.5	10-32 UNF - 2B	50	# 2 ¹	1/8	G-1/8	8	17.5	36	27	3	8	11	45	56	64
32	12.5	1/4-28 UNF - 2B	62	# 4	1/4	G-1/4	11	20.5	47	36	3	10	13	51	64	74
40	16.6	5/16-24 UNF - 2B	70	# 4	1/4	G-1/4	12	21	52	43	3	10	13	55	68	78
50	20.8	3/8-24 UNF - 2B	80	# 4	1/4	G-1/4	14	22.5	58	53	3	11	14	60	74	85
63	24.3	1/2-20 UNF - 2B	94	# 4	1/4	G-1/4	17	26	69	66	3	13	16	67	83	96
80	28.8	5/8-18 UNF - 2B	114	# 6	3/8	G-3/8	20	29.5	86	83	3	17	20	78	98	115

¹ Parker Triple-Lok™ Straight Thread Connector SAE #2 to 1/4" 37° flare can be used when this port thread is required. Contact your local Parker Tube Fitting distributor and specify part number 4-2 F5OX.

² Minimum 'W + Stroke' on V notch rod side may apply. See minimum rod extension page for details.

AN Mount Double Rod End – Rod Dimensions

Bore Ø	MM Rod Ø	Rod End														Rod Extension Dimensions		
		Style 9M ²		Style 4M		Style 9A ²		Style 4A		Style 8A		Style 55M				C	D	NA
		KK	A	KK	A	KK	A	KK	A	CC	A	AD	AE	AF	AM			
20	12	M8x1.25	10	M8x1	14	5/16-24	10	5/16-24	14	3/8-24	16	8	3	6	11	6	10	11
25	14	M10x1.5	12	M10x1.25	16	3/8-24	12	3/8-24	16	1/2-20	18	12	4	8	13	6	12	13
32	18	M12x1.75	15	M12x1.25	18	7/16-20	15	7/16-20	18	9/16-18	25	16	6	10	16	8	15	17
40	22	M16x2	20	M16x1.5	22	5/8-18	20	5/8-18	22	3/4-16	30	20	8	12	20	8	19	21
50	28	M20x2.5	24	M20x1.5	28	3/4-16	24	3/4-16	28	7/8-14	35	24	10	16	25	9	24	27
63	36	M27x3	30	M27x2	36	1-14	30	1-14	36	1 1/4-12	45	28	12	22	33	11	32	35
80	45	M33x3.5	35	M33x2	45	1 1/4-12	35	1 1/4-12	45	1 1/2-12	56	34	14	28	41	13	39	43

Rod End Dimensions

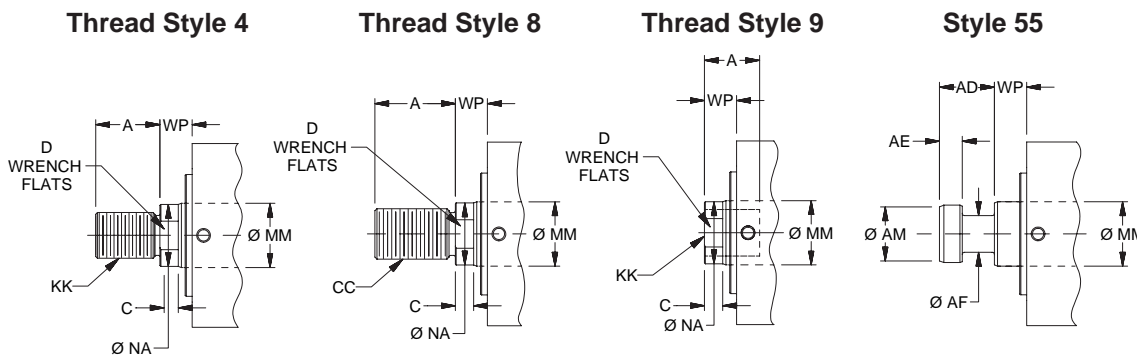

“Special” Thread Style 3
Special thread, extension, rod eye, blank, etc. are also available. To order, specify “Style 3” and give desired dimensions for KK, A, & WP. If otherwise special furnish dimensional sketch.

Style M Metric Tapped Both Ends Mount – Single Rod End – 20mm to 80mm Bore Size

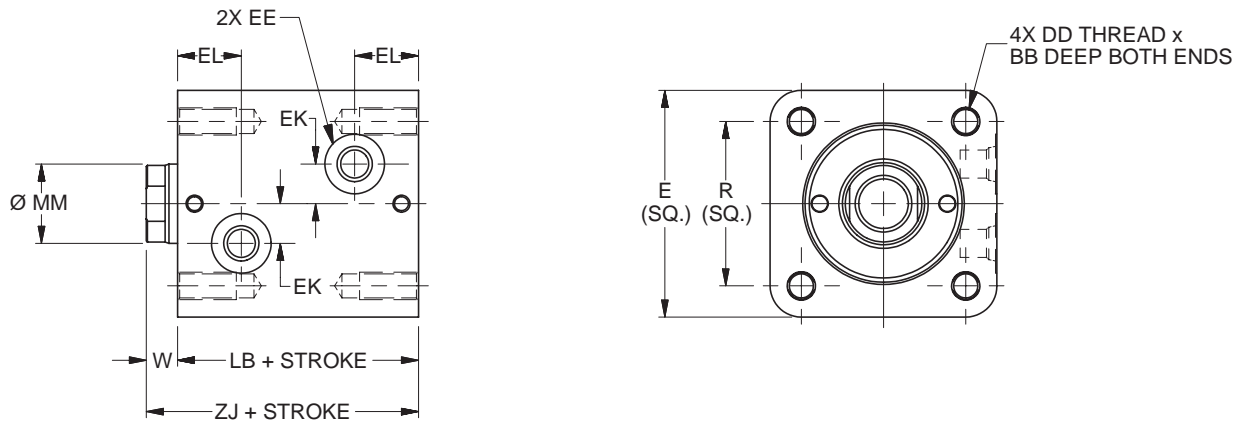

M Mount Single Rod End – Envelope and Mounting Dimensions

Bore Ø	BB	DD	E	EE			EK	EL	R	W	Add Stroke	
				SAE	NPT	BSP					LB	ZJ
20	10	M5x0.8 - 6H	44	# 2 ¹	1/8	G-1/8	6	16.5	30	8	43	51
25	10.4	M5x0.8 - 6H	50	# 2 ¹	1/8	G-1/8	8	17.5	36	8	45	53
32	12.5	M6x1 - 6H	62	# 4	1/4	G-1/4	11	20.5	47	10	51	61
40	16.6	M8x1.25 - 6H	70	# 4	1/4	G-1/4	12	21	52	10	55	65
50	20.7	M10x1.5 - 6H	80	# 4	1/4	G-1/4	14	22.5	58	11	60	71
63	24.9	M12x1.75 - 6H	94	# 4	1/4	G-1/4	17	26	69	13	67	80
80	29.0	M14x2 - 6H	114	# 6	3/8	G-3/8	20	29.5	86	17	78	95

¹ Parker Triple-Lok™ Straight Thread Connector SAE #2 to 1/4" 37° flare can be used when this port thread is required. Contact your local Parker Tube Fitting distributor and specify part number 4-2 F5OX.

M Mount Single Rod End – Rod Dimensions

Bore Ø	MM Rod Ø	Rod End														Rod Extension Dimensions		
		Style 9M		Style 4M		Style 9A		Style 4A		Style 8A		Style 55M				C	D	NA
		KK	A	KK	A	KK	A	KK	A	CC	A	AD	AE	AF	AM			
20	12	M8x1.25	10	M8x1	14	5/16-24	10	5/16-24	14	3/8-24	16	8	3	6	11	6	10	11
25	14	M10x1.5	12	M10x1.25	16	3/8-24	12	3/8-24	16	1/2-20	18	12	4	8	13	6	12	13
32	18	M12x1.75	15	M12x1.25	18	7/16-20	15	7/16-20	18	9/16-18	25	16	6	10	16	8	15	17
40	22	M16x2	20	M16x1.5	22	5/8-18	20	5/8-18	22	3/4-16	30	20	8	12	20	8	19	21
50	28	M20x2.5	24	M20x1.5	28	3/4-16	24	3/4-16	28	7/8-14	35	24	10	16	25	9	24	27
63	36	M27x3	30	M27x2	36	1-14	30	1-14	36	1 1/4-12	45	28	12	22	33	11	32	35
80	45	M33x3.5	35	M33x2	45	1 1/4-12	35	1 1/4-12	45	1 1/2-12	56	34	14	28	41	13	39	43

Rod End Dimensions

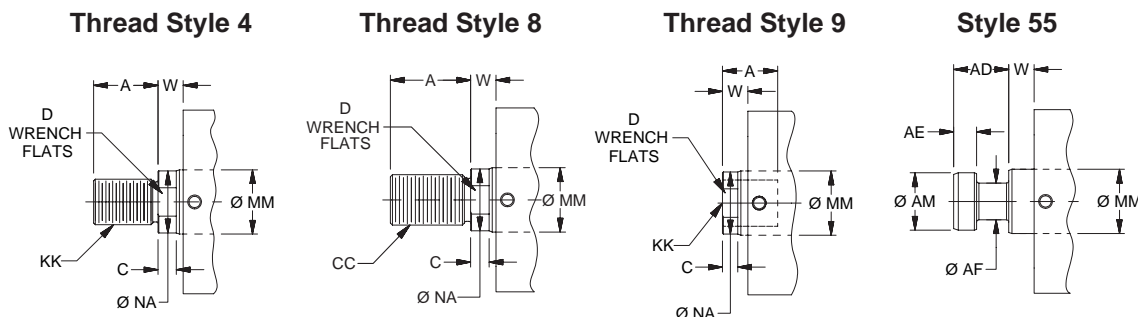

“Special” Thread Style 3
Special thread, extension, rod eye, blank, etc. are also available. To order, specify “Style 3” and give desired dimensions for KK, A, & W. If otherwise special furnish dimensional sketch.

Style M Metric Tapped Both Ends Mount – Double Rod End – 20mm to 80mm Bore Size

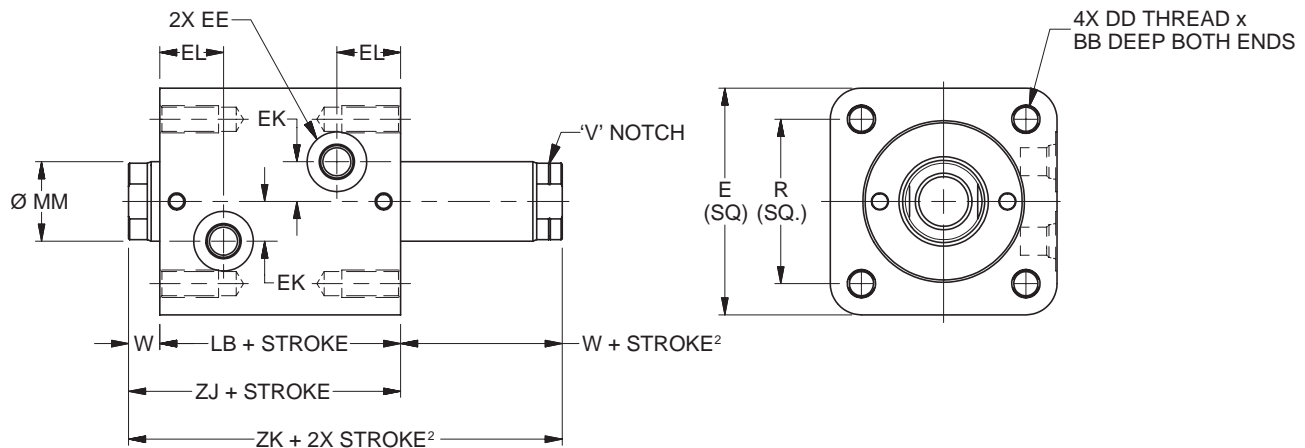

M Mount Double Rod End – Envelope and Mounting Dimensions

Bore	BB	DD	E	EE			EK	EL	R	W ²	Add Stroke		Add 2X Stroke ZK ²
				SAE	NPT	BSP					LB	ZJ	
20	10	M5x0.8 - 6H	44	# 2 ¹	1/8	G-1/8	6	16.5	30	8	43	51	59
25	10.4	M5x0.8 - 6H	50	# 2 ¹	1/8	G-1/8	8	17.5	36	8	45	53	61
32	12.5	M6x1 - 6H	62	# 4	1/4	G-1/4	11	20.5	47	10	51	61	71
40	16.6	M8x1.25 - 6H	70	# 4	1/4	G-1/4	12	21	52	10	55	65	75
50	20.7	M10x1.5 - 6H	80	# 4	1/4	G-1/4	14	22.5	58	11	60	71	82
63	24.9	M12x1.75 - 6H	94	# 4	1/4	G-1/4	17	26	69	13	67	80	93
80	29.0	M14x2 - 6H	114	# 6	3/8	G-3/8	20	29.5	86	17	78	95	112

¹ Parker Triple-Lok™ Straight Thread Connector SAE #2 to 1/4" 37° flare can be used when this port thread is required. Contact your local Parker Tube Fitting distributor and specify part number 4-2 F5OX.

² Minimum 'W + Stroke' on V notch rod side may apply. See minimum rod extension page for details.

M Mount Double Rod End – Rod Dimensions

Bore Ø	MM Rod Ø	Rod End														Rod Extension Dimensions		
		Style 9M ²		Style 4M		Style 9A ²		Style 4A		Style 8A		Style 55M				C	D	NA
		KK	A	KK	A	KK	A	KK	A	CC	A	AD	AE	AF	AM			
20	12	M8x1.25	10	M8x1	14	5/16-24	10	5/16-24	14	3/8-24	16	8	3	6	11	6	10	11
25	14	M10x1.5	12	M10x1.25	16	3/8-24	12	3/8-24	16	1/2-20	18	12	4	8	13	6	12	13
32	18	M12x1.75	15	M12x1.25	18	7/16-20	15	7/16-20	18	9/16-18	25	16	6	10	16	8	15	17
40	22	M16x2	20	M16x1.5	22	5/8-18	20	5/8-18	22	3/4-16	30	20	8	12	20	8	19	21
50	28	M20x2.5	24	M20x1.5	28	3/4-16	24	3/4-16	28	7/8-14	35	24	10	16	25	9	24	27
63	36	M27x3	30	M27x2	36	1-14	30	1-14	36	1 1/4-12	45	28	12	22	33	11	32	35
80	45	M33x3.5	35	M33x2	45	1 1/4-12	35	1 1/4-12	45	1 1/2-12	56	34	14	28	41	13	39	43

Rod End Dimensions

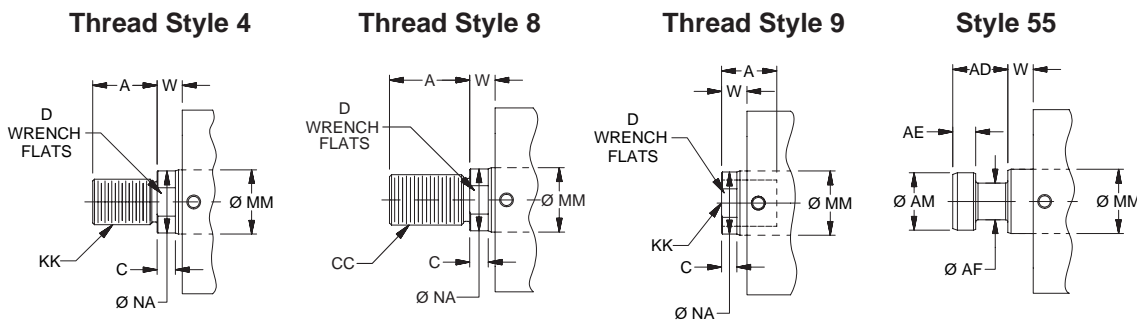

“Special” Thread Style 3
Special thread, extension, rod eye, blank, etc. are also available. To order, specify “Style 3” and give desired dimensions for KK, A, & W. If otherwise special furnish dimensional sketch.

Styles MN and MR Metric Tapped Both Ends Mounts with Pilot Gland or Pilot Cap – Single Rod End – 20mm to 80mm Bore Size

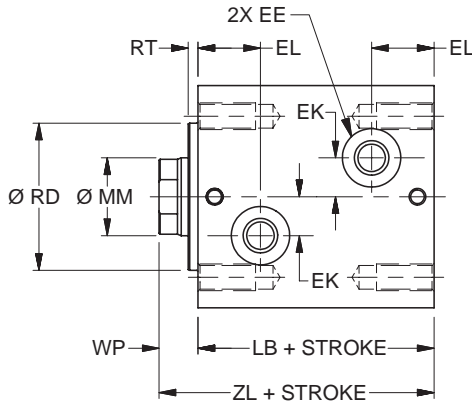

Style MN Metric Tapped Both Ends Mount with Pilot Gland

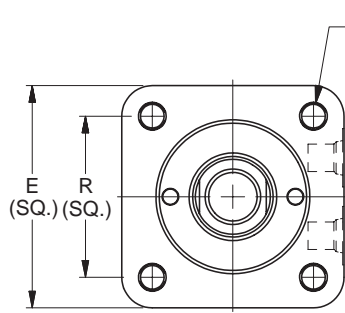

4X DD THREAD x BB DEEP BOTH ENDS

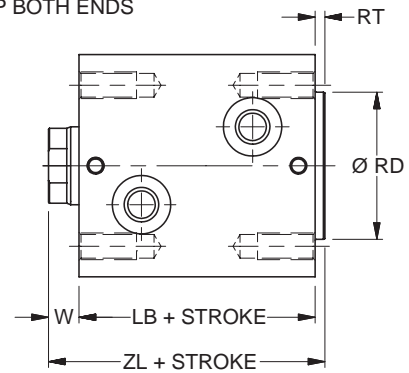

Style MR Metric Tapped Both Ends Mount with Pilot Cap

MN and MR Mount Single Rod End – Envelope and Mounting Dimensions

Bore	BB	DD	E	EE			EK	EL	R	RD Ø f9	RT	W	WP	Add Stroke	
				SAE	NPT	BSP								LB	ZL
20	10	M5x0.8 - 6H	44	# 2 ¹	1/8	G-1/8	6	16.5	30	24	3	8	11	43	54
25	10.4	M5x0.8 - 6H	50	# 2 ¹	1/8	G-1/8	8	17.5	36	27	3	8	11	45	56
32	12.5	M6x1 - 6H	62	# 4	1/4	G-1/4	11	20.5	47	36	3	10	13	51	64
40	16.6	M8x1.25 - 6H	70	# 4	1/4	G-1/4	12	21	52	43	3	10	13	55	68
50	20.7	M10x1.5 - 6H	80	# 4	1/4	G-1/4	14	22.5	58	53	3	11	14	60	74
63	24.9	M12x1.75 - 6H	94	# 4	1/4	G-1/4	17	26	69	66	3	13	16	67	83
80	29.0	M14x2 - 6H	114	# 6	3/8	G-3/8	20	29.5	86	83	3	17	20	78	98

¹ Parker Triple-Lok™ Straight Thread Connector SAE #2 to 1/4" 37° flare can be used when this port thread is required. Contact your local Parker Tube Fitting distributor and specify part number 4-2 F5OX.

MN and MR Mount Single Rod End – Rod Dimensions

Bore Ø	MM Rod Ø	Rod End														Rod Extension Dimensions		
		Style 9M		Style 4M		Style 9A		Style 4A		Style 8A		Style 55M				C	D	NA
		KK	A	KK	A	KK	A	KK	A	CC	A	AD	AE	AF	AM			
20	12	M8x1.25	10	M8x1	14	5/16-24	10	5/16-24	14	3/8-24	16	8	3	6	11	6	10	11
25	14	M10x1.5	12	M10x1.25	16	3/8-24	12	3/8-24	16	1/2-20	18	12	4	8	13	6	12	13
32	18	M12x1.75	15	M12x1.25	18	7/16-20	15	7/16-20	18	9/16-18	25	16	6	10	16	8	15	17
40	22	M16x2	20	M16x1.5	22	5/8-18	20	5/8-18	22	3/4-16	30	20	8	12	20	8	19	21
50	28	M20x2.5	24	M20x1.5	28	3/4-16	24	3/4-16	28	7/8-14	35	24	10	16	25	9	24	27
63	36	M27x3	30	M27x2	36	1-14	30	1-14	36	1 1/4-12	45	28	12	22	33	11	32	35
80	45	M33x3.5	35	M33x2	45	1 1/4-12	35	1 1/4-12	45	1 1/2-12	56	34	14	28	41	13	39	43

Rod End Dimensions

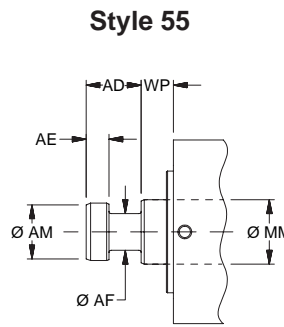
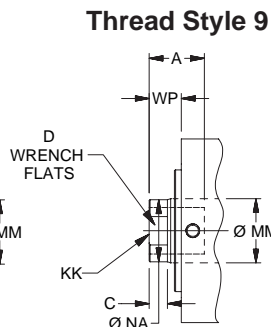
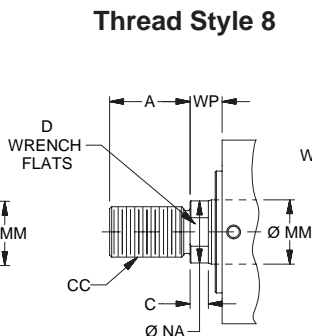
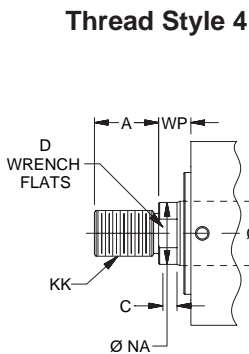

“Special” Thread Style 3

Special thread, extension, rod eye, blank, etc. are also available. To order, specify “Style 3” and give desired dimensions for KK, A, & W (MR Mount) or WP (MN Mount) If otherwise special furnish dimensional sketch.

Style MN Metric Tapped Both Ends Mount with Pilot Gland – Double Rod End – 20mm to 80mm Bore Size

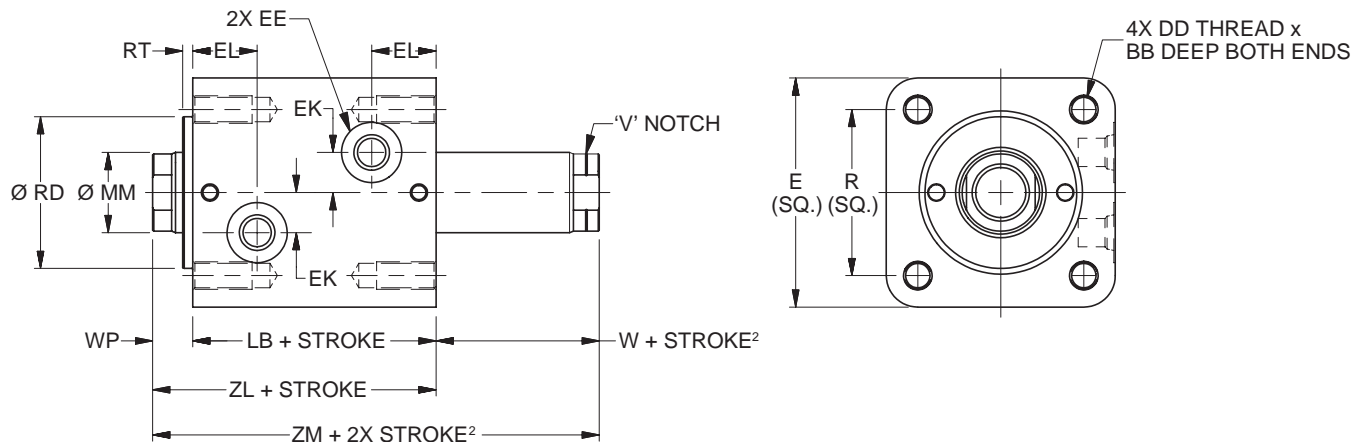

MN Mount Double Rod End – Envelope and Mounting Dimensions

Bore Ø	BB	DD	E	EE			EK	EL	R	RD Ø f9	RT	W²	WP	Add Stroke		Add 2X Stroke ZM²
				SAE	NPTF	BSP								LB	ZL	
20	10	M5x0.8 - 6H	44	# 2¹	1/8	G-1/8	6	16.5	30	24	3	8	11	43	54	62
25	10.4	M5x0.8 - 6H	50	# 2¹	1/8	G-1/8	8	17.5	36	27	3	8	11	45	56	64
32	12.5	M6x1 - 6H	62	# 4	1/4	G-1/4	11	20.5	47	36	3	10	13	51	64	74
40	16.6	M8x1.25 - 6H	70	# 4	1/4	G-1/4	12	21	52	43	3	10	13	55	68	78
50	20.7	M10x1.5 - 6H	80	# 4	1/4	G-1/4	14	22.5	58	53	3	11	14	60	74	85
63	24.9	M12x1.75 - 6H	94	# 4	1/4	G-1/4	17	26	69	66	3	13	16	67	83	96
80	29.0	M14x2 - 6H	114	# 6	3/8	G-3/8	20	29.5	86	83	3	17	20	78	98	115

¹ Parker Triple-Lok™ Straight Thread Connector SAE #2 to ¼" 37° flare can be used when this port thread is required. Contact your local Parker Tube Fitting distributor and specify part number 4-2 F5OX.

² Minimum 'W + Stroke' on V notch rod side may apply. See minimum rod extension page for details.

MN Mount Double Rod End – Rod Dimensions

Bore Ø	MM Rod Ø	Rod End														Rod Extension Dimensions		
		Style 9M²		Style 4M		Style 9A²		Style 4A		Style 8A		Style 55M				C	D	NA
		KK	A	KK	A	KK	A	KK	A	CC	A	AD	AE	AF	AM			
20	12	M8x1.25	10	M8x1	14	5/16-24	10	5/16-24	14	3/8-24	16	8	3	6	11	6	10	11
25	14	M10x1.5	12	M10x1.25	16	3/8-24	12	3/8-24	16	1/2-20	18	12	4	8	13	6	12	13
32	18	M12x1.75	15	M12x1.25	18	7/16-20	15	7/16-20	18	9/16-18	25	16	6	10	16	8	15	17
40	22	M16x2	20	M16x1.5	22	5/8-18	20	5/8-18	22	3/4-16	30	20	8	12	20	8	19	21
50	28	M20x2.5	24	M20x1.5	28	3/4-16	24	3/4-16	28	7/8-14	35	24	10	16	25	9	24	27
63	36	M27x3	30	M27x2	36	1-14	30	1-14	36	1 1/4-12	45	28	12	22	33	11	32	35
80	45	M33x3.5	35	M33x2	45	1 1/4-12	35	1 1/4-12	45	1 1/2-12	56	34	14	28	41	13	39	43

Rod End Dimensions

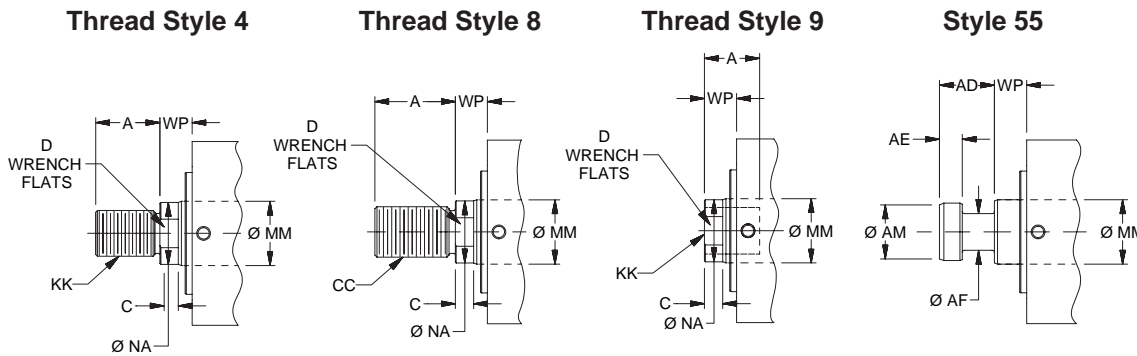

J & H Mounts – Single Rod End

Styles J Rectangular Head Flange & H Rectangular Cap Flange Mounts – Single Rod End – 20mm to 80mm Bore Size

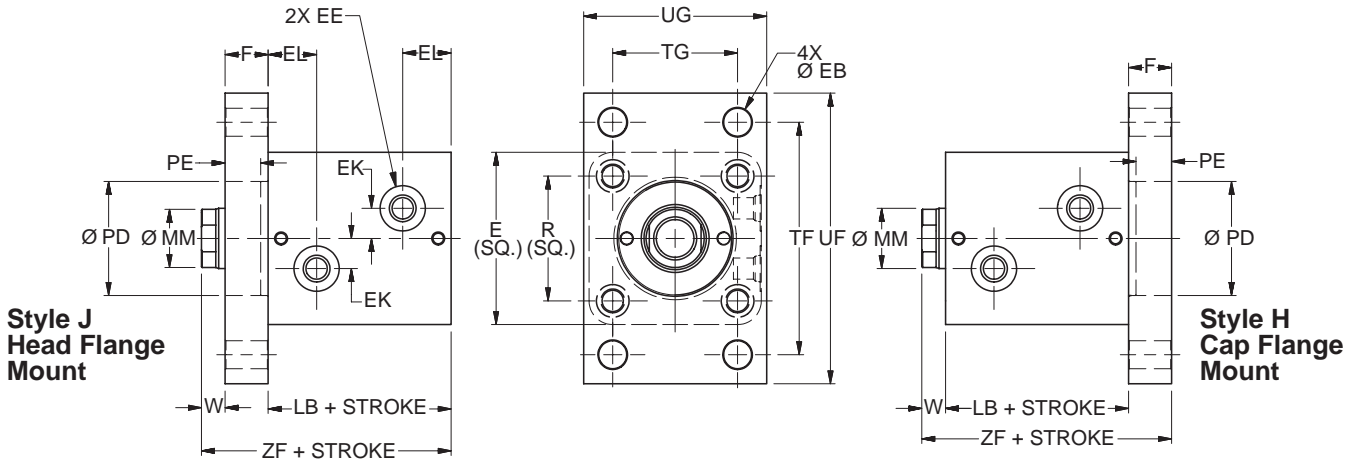

J & H Mounts Single Rod End – Envelope and Mounting Dimensions

Bore Ø	E	EE			EK	EL	F	EB Ø	PD Ø H9	PE	R	TF	TG	UF	UG	W	Add Stroke	
		SAE	NPTF	BSP													LB	ZF
20	44	#2 ¹	1/8	G-1/8	6	16.5	10	5.5	24	7	30	60	30	75	46	8	43	61
25	50	#2 ¹	1/8	G-1/8	8	17.5	12	5.5	27	9	36	66	36	80	52	8	45	65
32	62	#4	1/4	G-1/4	11	20.5	12	6.8	36	9	47	80	40	95	62	10	51	73
40	70	#4	1/4	G-1/4	12	21	16	11	43	13	52	96	46	118	70	10	55	81
50	80	#4	1/4	G-1/4	14	22.5	20	13.5	53	17	58	108	58	135	85	11	60	91
63	94	#4	1/4	G-1/4	17	26	20	15	66	17	69	124	65	150	98	13	67	100
80	114	#6	3/8	G-3/8	20	29.5	25	17	83	21	86	154	87	185	118	17	78	120

¹ Parker Triple-Lok™ Straight Thread Connector SAE #2 to 1/4" 37° flare can be used when this port thread is required. Contact your local Parker Tube Fitting distributor and specify part number 4-2 F5OX.

J & H Mounts Single Rod End – Rod Dimensions

Bore Ø	MM Rod Ø	Rod End														Rod Extension Dimensions		
		Style 9M		Style 4M		Style 9A		Style 4A		Style 8A		Style 55M						
		KK	A	KK	A	KK	A	KK	A	CC	A	AD	AE	AF	AM	C	D	NA
20	12	M8x1.25	10	M8x1	14	5/16-24	10	5/16-24	14	3/8-24	16	8	3	6	11	6	10	11
25	14	M10x1.5	12	M10x1.25	16	3/8-24	12	3/8-24	16	1/2-20	18	12	4	8	13	6	12	13
32	18	M12x1.75	15	M12x1.25	18	7/16-20	15	7/16-20	18	9/16-18	25	16	6	10	16	8	15	17
40	22	M16x2	20	M16x1.5	22	5/8-18	20	5/8-18	22	3/4-16	30	20	8	12	20	8	19	21
50	28	M20x2.5	24	M20x1.5	28	3/4-16	24	3/4-16	28	7/8-14	35	24	10	16	25	9	24	27
63	36	M27x3	30	M27x2	36	1-14	30	1-14	36	1 1/4-12	45	28	12	22	33	11	32	35
80	45	M33x3.5	35	M33x2	45	1 1/4-12	35	1 1/4-12	45	1 1/2-12	56	34	14	28	41	13	39	43

Rod End Dimensions

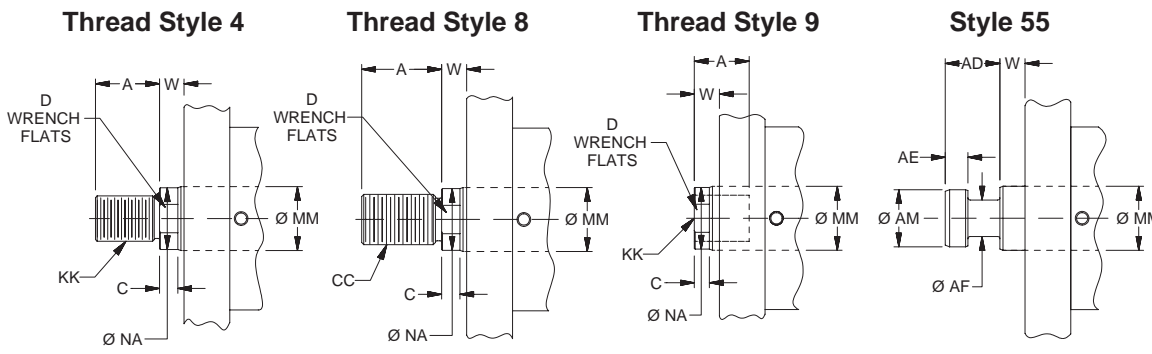

“Special” Thread Style 3
Special thread, extension, rod eye, blank, etc. are also available. To order, specify “Style 3” and give desired dimensions for KK, A, & W. If otherwise special furnish dimensional sketch.

Style J Rectangular Head Flange Mount – Double Rod End – 20mm to 80mm Bore Size

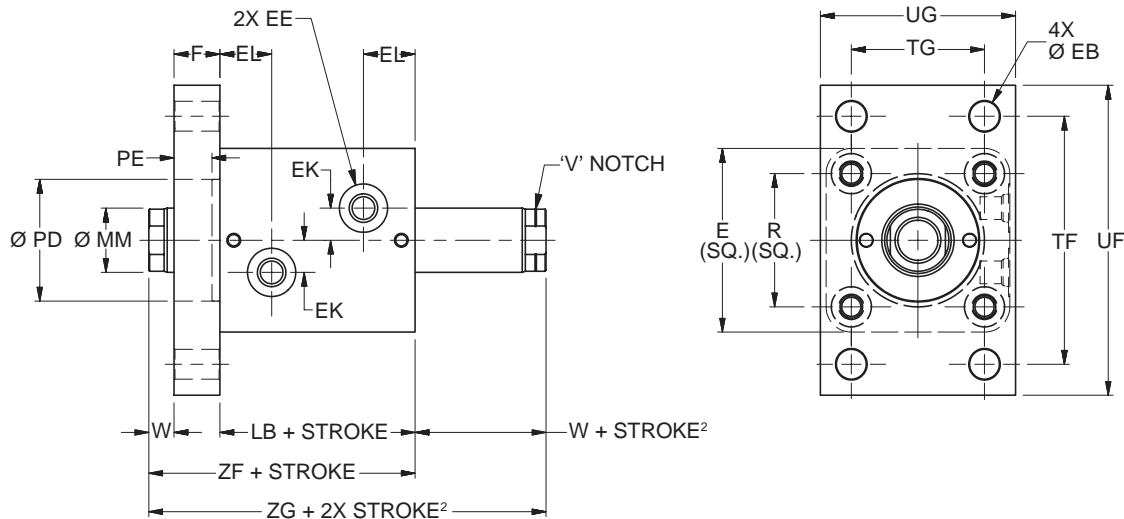

J Mount Double Rod End – Envelope and Mounting Dimensions

Bore Ø	E	EE			EK	EL	F	EB Ø	PD Ø H9	PE	R	TF	TG	UF	UG	W ²	Add Stroke		Add 2X Stroke ZG ²
		SAE	NPTF	BSP													LB	ZF	
20	44	#2 ¹	1/8	G-1/8	6	16.5	10	5.5	24	7	30	60	30	75	46	8	43	61	69
25	50	#2 ¹	1/8	G-1/8	8	17.5	12	5.5	27	9	36	66	36	80	52	8	45	65	73
32	62	#4	1/4	G-1/4	11	20.5	12	6.8	36	9	47	80	40	95	62	10	51	73	83
40	70	#4	1/4	G-1/4	12	21	16	11	43	13	52	96	46	118	70	10	55	81	91
50	80	#4	1/4	G-1/4	14	22.5	20	13.5	53	17	58	108	58	135	85	11	60	91	102
63	94	#4	1/4	G-1/4	17	26	20	15	66	17	69	124	65	150	98	13	67	100	113
80	114	#6	3/8	G-3/8	20	29.5	25	17	83	21	86	154	87	185	118	17	78	120	137

¹ Parker Triple-Lok™ Straight Thread Connector SAE #2 to 1/4" 37° flare can be used when this port thread is required. Contact your local Parker Tube Fitting distributor and specify part number 4-2 F5OX.

² Minimum 'W + Stroke' on V notch rod side may apply. See minimum rod extension page for details.

J Mount Double Rod End – Rod Dimensions

Bore Ø	MM Rod Ø	Rod End														Rod Extension Dimensions		
		Style 9M ²		Style 4M		Style 9A ²		Style 4A		Style 8A		Style 55M				C	D	NA
		KK	A	KK	A	KK	A	KK	A	CC	A	AD	AE	AF	AM			
20	12	M8x1.25	10	M8x1	14	5/16-24	10	5/16-24	14	3/8-24	16	8	3	6	11	6	10	11
25	14	M10x1.5	12	M10x1.25	16	3/8-24	12	3/8-24	16	1/2-20	18	12	4	8	13	6	12	13
32	18	M12x1.75	15	M12x1.25	18	7/16-20	15	7/16-20	18	9/16-18	25	16	6	10	16	8	15	17
40	22	M16x2	20	M16x1.5	22	5/8-18	20	5/8-18	22	3/4-16	30	20	8	12	20	8	19	21
50	28	M20x2.5	24	M20x1.5	28	3/4-16	24	3/4-16	28	7/8-14	35	24	10	16	25	9	24	27
63	36	M27x3	30	M27x2	36	1-14	30	1-14	36	1 1/4-12	45	28	12	22	33	11	32	35
80	45	M33x3.5	35	M33x2	45	1 1/4-12	35	1 1/4-12	45	1 1/2-12	56	34	14	28	41	13	39	43

Rod End Dimensions

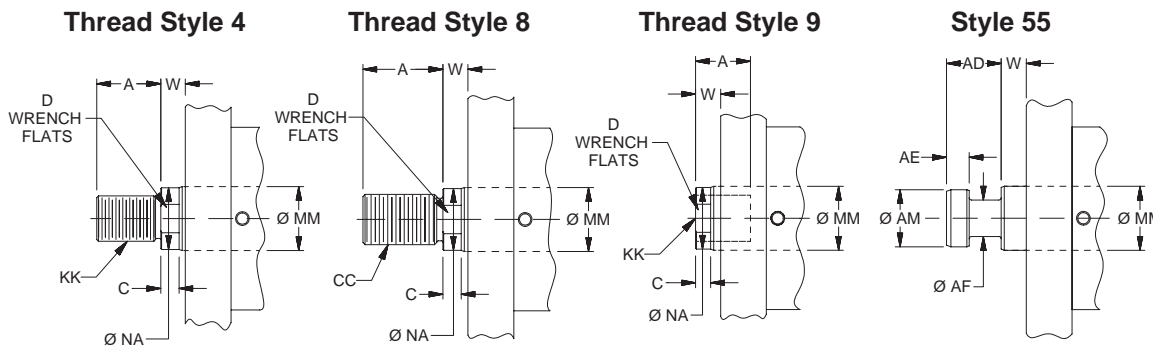

“Special” Thread Style 3
Special thread, extension, rod eye, blank, etc. are also available. To order, specify “Style 3” and give desired dimensions for KK, A, & W. If otherwise special furnish dimensional sketch.

C Mount – Single Rod End

Style C Foot Mount – Single Rod End – 25mm to 63mm Bore Size

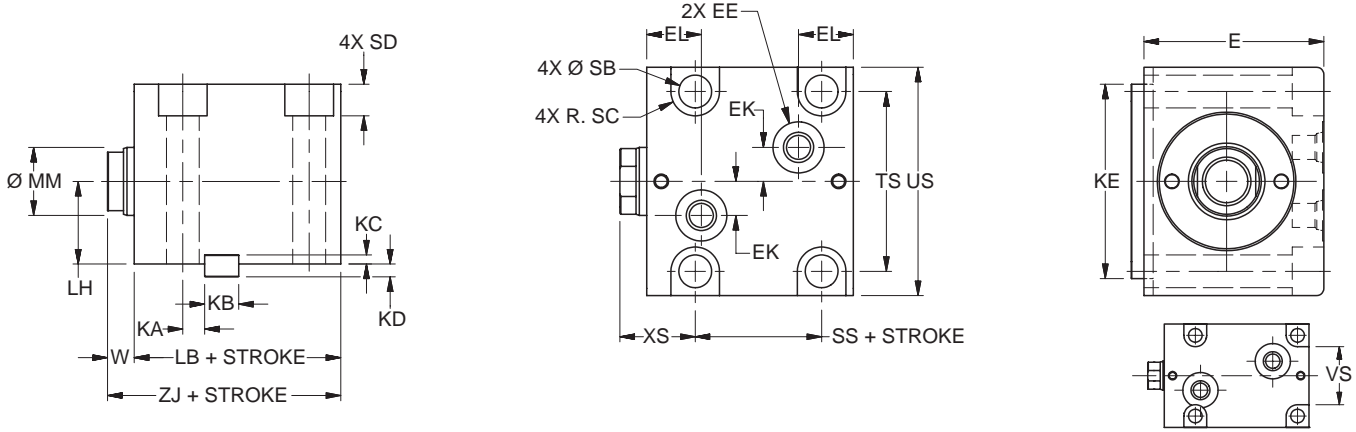

C Mount Single Rod End – Envelope and Mounting Dimensions

Bore Ø	E	ED Ø	EE				EF	EK	EL	EM	KA	KB	KC	KD	KE
			SAE	NPT	BSP	Mani-fold									
25	45	10	# 2 ¹	1/8	G-1/8	3	2	7	17.5	15.8	8.5	8	3.25	3.75	45
32	56	10	# 4	1/4	G-1/4	3	2	11	20.5	18.5	8	12	3.25	4.75	63
40	64	12	# 4	1/4	G-1/4	3	2	12	21	19	8	12	3.25	4.75	70
50	74	15	# 4	1/4	G-1/4	4	2	14	22.5	21	9	14	3.75	5.25	80
63	89	15	# 4	1/4	G-1/4	4	2	17	26	24.5	11	16	4.25	5.75	100

¹ Parker Triple-Lok™ Straight Thread Connector SAE #2 to 1/4" 37° flare can be used when this port thread is required. Contact your local Parker Tube Fitting distributor and specify part number 4-2 F50X.

25mm & 32mm BOLT HOLE DETAIL

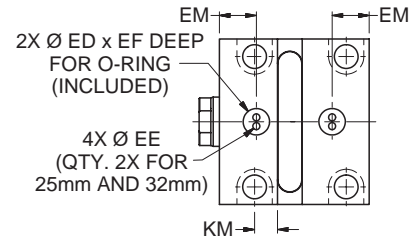

MANIFOLD PORT OPTION DETAIL
CAUTION: KM key slot location is for manifold ports only. Do not use for top mounted ports. KA key slot location is for top mounted ports. Do not use for manifold ports.

C Mount Single Rod End – Rod Dimensions

Bore Ø	KM	LH	SB Ø	SC	SD	TS	US	VS	W	XS	Add Stroke			Min. Stroke For M Port
											LB	SS	ZJ	
25	8.5	20	6.8	5.5	6.5	39	50	28	8	23	45	24.5	53	10
32	8	25	9	7	8.6	56	70	42	10	30	51	24	61	15
40	8	29	11	8.75	10.8	62	80	-	10	30	55	23	65	15
50	13	34	13.5	10	13	74	94	-	11	31	60	27	71	20
63	15.5	42	16	11.5	15.2	90	114	-	13	33	67	32	80	20

C Mount Single Rod End – Rod Dimensions

Bore Ø	MM Rod Ø	Rod End														Rod Extension Dimensions		
		Style 9M		Style 4M		Style 9A		Style 4A		Style 8A		Style 55M				C	D	NA
		KK	A	KK	A	KK	A	KK	A	CC	A	AD	AE	AF	AM			
25	14	M10x1.5	12	M10x1.25	16	3/8-24	12	3/8-24	16	1/2-20	18	12	4	8	13	6	12	13
32	18	M12x1.75	15	M12x1.25	18	7/16-20	15	7/16-20	18	9/16-18	25	16	6	10	16	8	15	17
40	22	M16x2	20	M16x1.5	22	5/8-18	20	5/8-18	22	3/4-16	30	20	8	12	20	8	19	21
50	28	M20x2.5	24	M20x1.5	28	3/4-16	24	3/4-16	28	7/8-14	35	24	10	16	25	9	24	27
63	36	M27x3	30	M27x2	36	1-14	30	1-14	36	1 1/4-12	45	28	12	22	33	11	32	35

Rod End Dimensions

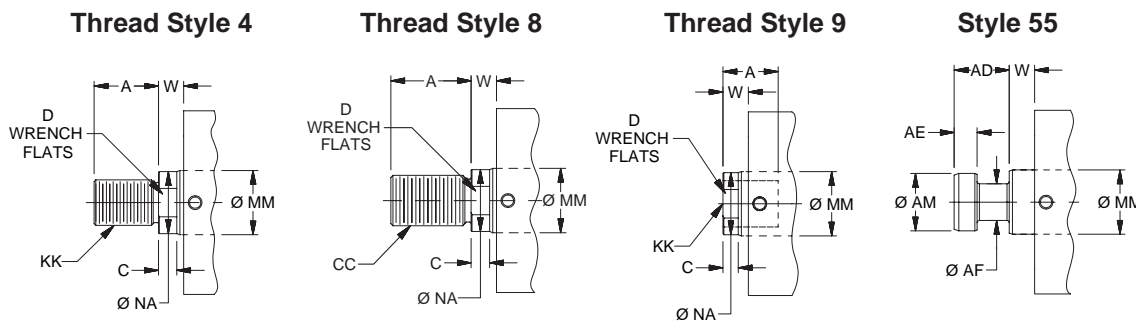

“Special” Thread Style 3

Special thread, extension, rod eye, blank, etc. are also available. To order, specify “Style 3” and give desired dimensions for KK, A, & W. If otherwise special furnish dimensional sketch.

C Mount – Double Rod End

Style C Foot Mount – Double Rod End – 25mm to 63mm Bore Size

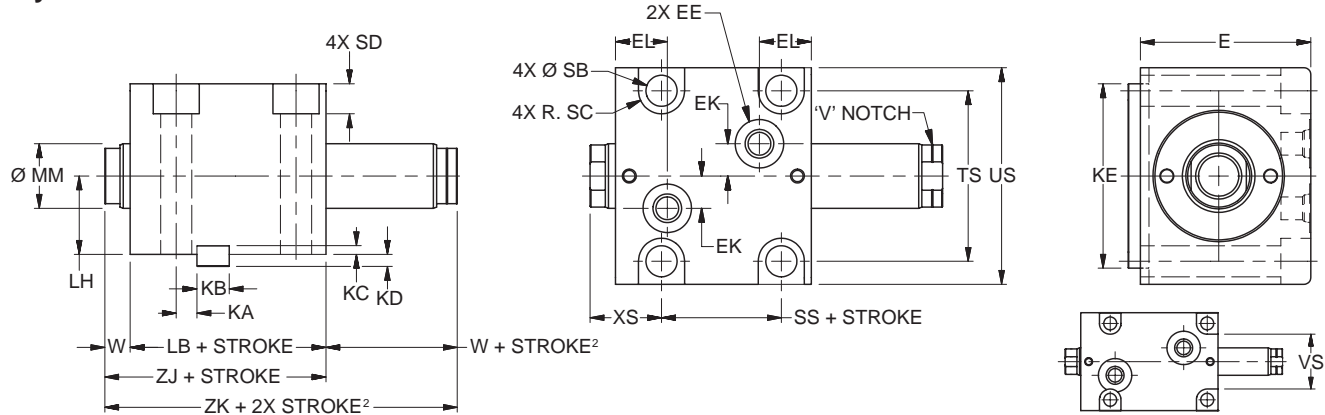

C Mount Double Rod End – Envelope and Mounting Dimensions

Bore Ø	E	ED Ø	EE				EF	EK	EL	EM	KA	KB	KC	KD	KE
			SAE	NPT	BSP	Manifold									
25	45	10	# 2 ¹	1/8	G-1/8	3	2	7	17.5	15.8	8.5	8	3.25	3.75	45
32	56	10	# 4	1/4	G-1/4	3	2	11	20.5	18.5	8	12	3.25	4.75	63
40	64	12	# 4	1/4	G-1/4	3	2	12	21	19	8	12	3.25	4.75	70
50	74	15	# 4	1/4	G-1/4	4	2	14	22.5	21	9	14	3.75	5.25	80
63	89	15	# 4	1/4	G-1/4	4	2	17	26	24.5	11	16	4.25	5.75	100

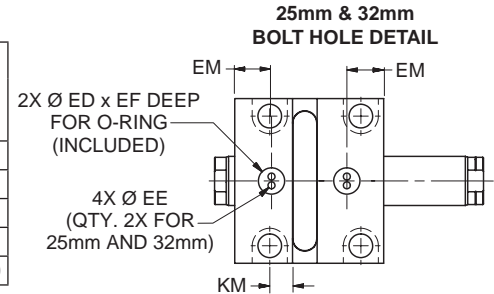

¹ Parker Triple-Lok™ Straight Thread Connector SAE #2 to 1/4" 37° flare can be used when this port thread is required. Contact your local Parker Tube Fitting distributor and specify part number 4-2 F5OX.

² Minimum 'W + Stroke' on V notch rod side may apply. See minimum rod extension page for details.

MANIFOLD PORT OPTION DETAIL
CAUTION: KM key slot location is for manifold ports only. Do not use for top mounted ports. KA key slot location is for top mounted ports. Do not use for manifold ports.

C Mount Double Rod End – Rod Dimensions

Bore Ø	KM	LH	SB Ø	SC	SD	TS	US	VS	W ²	XS	Add Stroke			Add 2X Stroke	Min. Stroke For M Port
											LB	SS	ZJ	ZK ²	
25	8.5	20	6.8	5.5	6.5	39	50	28	8	23	45	24.5	53	61	10
32	8	25	9	7	8.6	56	70	42	10	30	51	24	61	71	15
40	8	29	11	8.75	10.8	62	80	-	10	30	55	23	65	75	15
50	13	34	13.5	10	13	74	94	-	11	31	60	27	71	82	20
63	15.5	42	16	11.5	15.2	90	114	-	13	33	67	32	80	93	20

C Mount Single Rod End – Rod Dimensions

Bore Ø	MM Rod Ø	Rod End														Rod Extension Dimensions		
		Style 9M ²		Style 4M		Style 9A ²		Style 4A		Style 8A		Style 55M				C	D	NA
		KK	A	KK	A	KK	A	KK	A	CC	A	AD	AE	AF	AM			
25	14	M10x1.5	12	M10x1.25	16	3/8-24	12	3/8-24	16	1/2-20	18	12	4	8	13	6	12	13
32	18	M12x1.75	15	M12x1.25	18	7/16-20	15	7/16-20	18	9/16-18	25	16	6	10	16	8	15	17
40	22	M16x2	20	M16x1.5	22	5/8-18	20	5/8-18	22	3/4-16	30	20	8	12	20	8	19	21
50	28	M20x2.5	24	M20x1.5	28	3/4-16	24	3/4-16	28	7/8-14	35	24	10	16	25	9	24	27
63	36	M27x3	30	M27x2	36	1-14	30	1-14	36	1 1/4-12	45	28	12	22	33	11	32	35

Rod End Dimensions

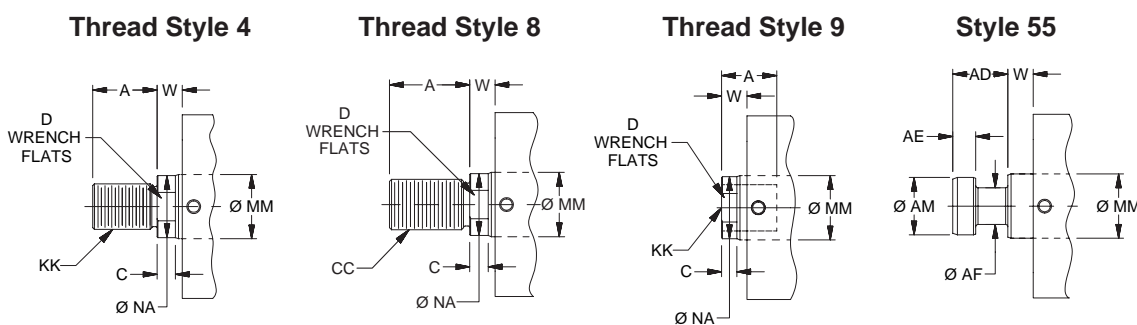

“Special” Thread Style 3
Special thread, extension, rod eye, blank, etc. are also available. To order, specify “Style 3” and give desired dimensions for KK, A, & W. If otherwise special furnish dimensional sketch.

Style CN Foot Mount with Pilot Gland – Single Rod End – 25mm to 63mm Bore Size

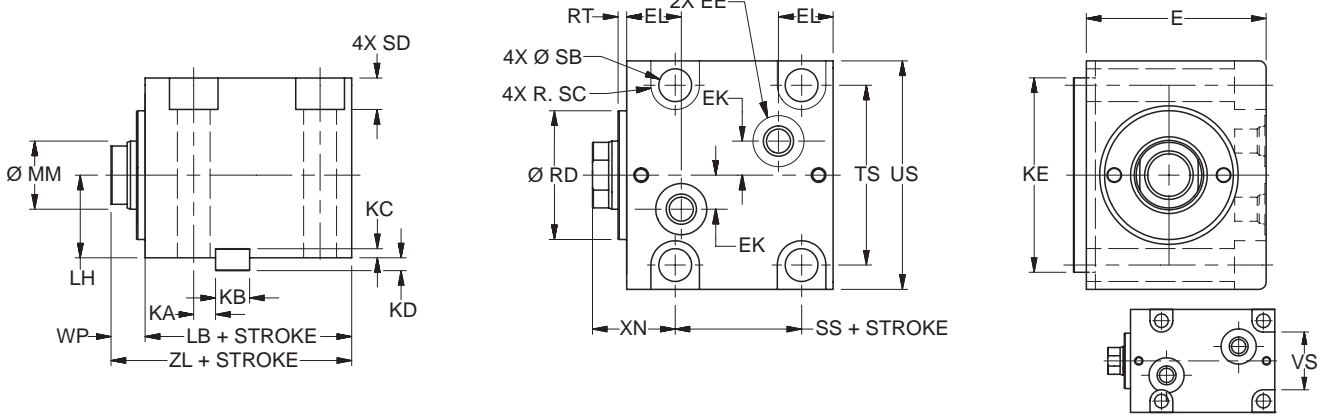

CN Mount Single Rod End – Envelope and Mounting Dimensions

Bore Ø	E	ED Ø	EE				EF	EK	EL	EM	KA	KB	KC	KD	KE
			SAE	NPT	BSP	Mani-fold									
25	45	10	# 2'	1/8	G-1/8	3	2	7	17.5	15.8	8.5	8	3.25	3.75	45
32	56	10	# 4	1/4	G-1/4	3	2	11	20.5	18.5	8	12	3.25	4.75	63
40	64	12	# 4	1/4	G-1/4	3	2	12	21	19	8	12	3.25	4.75	70
50	74	15	# 4	1/4	G-1/4	4	2	14	22.5	21	9	14	3.75	5.25	80
63	89	15	# 4	1/4	G-1/4	4	2	17	26	24.5	11	16	4.25	5.75	100

¹ Parker Triple-Lok™ Straight Thread Connector SAE #2 to 1/4" 37° flare can be used when this port thread is required. Contact your local Parker Tube Fitting distributor and specify part number 4-2 F5OX.

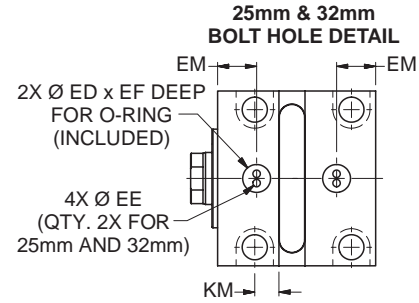

MANIFOLD PORT OPTION DETAIL

CAUTION: KM key slot location is for manifold ports only. Do not use for top mounted ports. KA key slot location is for top mounted ports. Do not use for manifold ports.

CN Mount Single Rod End – Rod Dimensions

Bore Ø	KM	LH	RD Ø f9	RT	SB Ø	SC	SD	TS	US	VS	WP	XN	Add Stroke			Min. Stroke For M Port
													LB	SS	ZL	
25	8.5	20	27	3	6.8	5.5	6.5	39	50	28	11	26	45	24.5	56	10
32	8	25	36	3	9	7	8.6	56	70	42	13	33	51	24	64	15
40	8	29	43	3	11	8.75	10.8	62	80	-	13	33	55	23	68	15
50	13	34	53	3	13.5	10	13	74	94	-	14	34	60	27	74	20
63	15.5	42	66	3	16	11.5	15.2	90	114	-	16	36	67	32	83	20

CN Mount Single Rod End – Rod Dimensions

Bore Ø	MM Rod Ø	Rod End														Rod Extension Dimensions		
		Style 9M		Style 4M		Style 9A		Style 4A		Style 8A		Style 55M				C	D	NA
		KK	A	KK	A	KK	A	KK	A	CC	A	AD	AE	AF	AM			
25	14	M10x1.5	12	M10x1.25	16	3/8-24	12	3/8-24	16	1/2-20	18	12	4	8	13	6	12	13
32	18	M12x1.75	15	M12x1.25	18	7/16-20	15	7/16-20	18	9/16-18	25	16	6	10	16	8	15	17
40	22	M16x2	20	M16x1.5	22	5/8-18	20	5/8-18	22	3/4-16	30	20	8	12	20	8	19	21
50	28	M20x2.5	24	M20x1.5	28	3/4-16	24	3/4-16	28	7/8-14	35	24	10	16	25	9	24	27
63	36	M27x3	30	M27x2	36	1-14	30	1-14	36	1 1/4-12	45	28	12	22	33	11	32	35

**Rod End Dimensions
Thread Style 4**

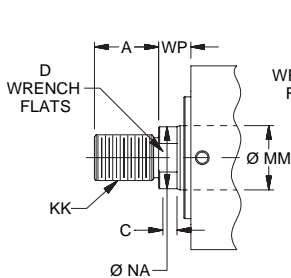

Thread Style 8

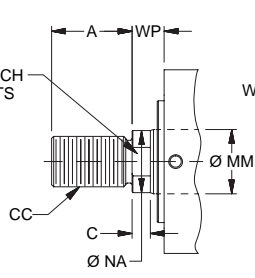

Thread Style 9

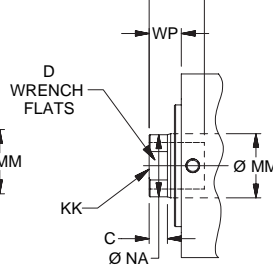

Style 55

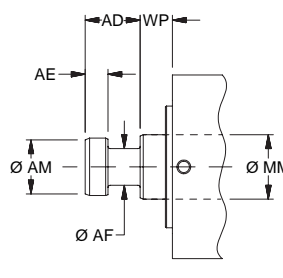

“Special” Thread Style 3

Special thread, extension, rod eye, blank, etc. are also available.

To order, specify “Style 3” and give desired dimensions for KK, A, & WP. If otherwise special furnish dimensional sketch.

Style CN Foot Mount with Pilot Gland – Double Rod End – 25mm to 63mm Bore Size

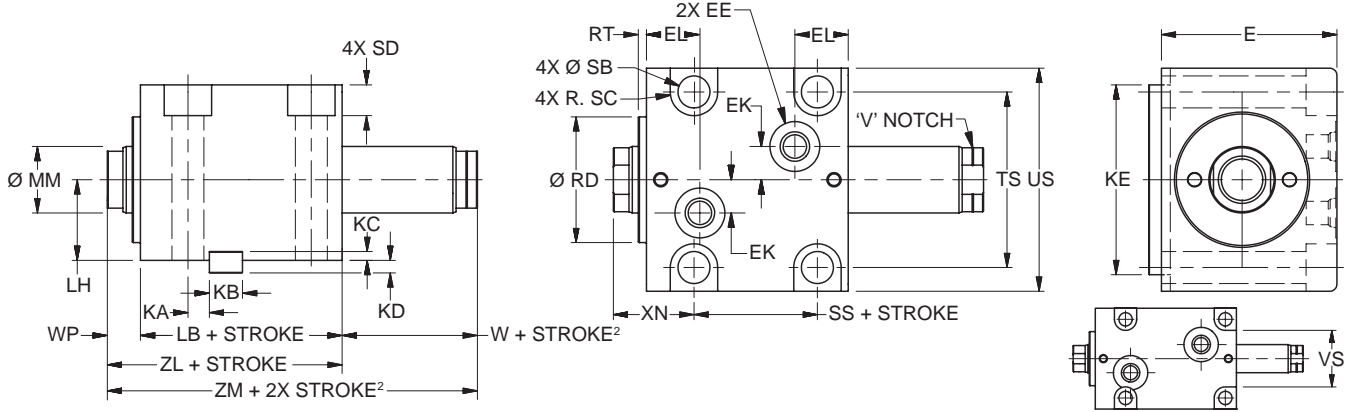

CN Mount Double Rod End – Envelope and Mounting Dimensions

Bore Ø	E	ED Ø	EE				EF	EK	EL	EM	KA	KB	KC	KD	KE
			SAE	NPT	BSP	Mani- fold									
25	45	10	# 2 ¹	1/8	G-1/8	3	2	7	17.5	15.8	8.5	8	3.25	3.75	45
32	56	10	# 4	1/4	G-1/4	3	2	11	20.5	18.5	8	12	3.25	4.75	63
40	64	12	# 4	1/4	G-1/4	3	2	12	21	19	8	12	3.25	4.75	70
50	74	15	# 4	1/4	G-1/4	4	2	14	22.5	21	9	14	3.75	5.25	80
63	89	15	# 4	1/4	G-1/4	4	2	17	26	24.5	11	16	4.25	5.75	100

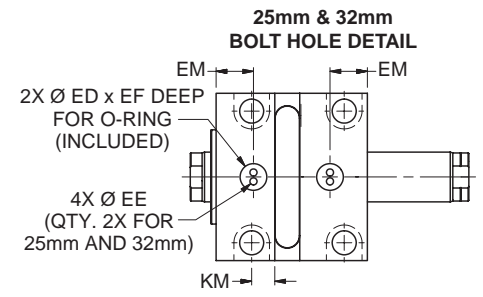

¹ Parker Triple-Lok™ Straight Thread Connector SAE #2 to 1/4" 37° flare can be used when this port thread is required. Contact your local Parker Tube Fitting distributor and specify part number 4-2 F5OX.
² Minimum 'W + Stroke' on V notch rod side may apply. See minimum rod extension page for details.

MANIFOLD PORT OPTION DETAIL
 CAUTION: KM key slot location is for manifold ports only. Do not use for top mounted ports.
 KA key slot location is for top mounted ports. Do not use for manifold ports.

CN Mount Double Rod End – Envelope and Mounting Dimensions

Bore Ø	KM	LH	RD Ø f9	RT	SB Ø	SC	SD	TS	US	VS	W ²	WP	XN	Add Stroke			Add 2X Stroke ZM ²	Min. Stroke For M Port
														LB	SS	ZL		
25	8.5	20	27	3	6.8	5.5	6.5	39	50	28	8	11	26	45	24.5	56	64	10
32	8	25	36	3	9	7	8.6	56	70	42	10	13	33	51	24	64	74	15
40	8	29	43	3	11	8.75	10.8	62	80	-	10	13	33	55	23	68	78	15
50	13	34	53	3	13.5	10	13	74	94	-	11	14	34	60	27	74	85	20
63	15.5	42	66	3	16	11.5	15.2	90	114	-	13	16	36	67	32	83	96	20

CN Mount Double Rod End – Rod Dimensions

Bore Ø	MM Rod Ø	Rod End														Rod Extension Dimensions		
		Style 9M ²		Style 4M		Style 9A ²		Style 4A		Style 8A		Style 55M						
		KK	A	KK	A	KK	A	KK	A	CC	A	AD	AE	AF	AM	C	D	NA
25	14	M10x1.5	12	M10x1.25	16	3/8-24	12	3/8-24	16	1/2-20	18	12	4	8	13	6	12	13
32	18	M12x1.75	15	M12x1.25	18	7/16-20	15	7/16-20	18	9/16-18	25	16	6	10	16	8	15	17
40	22	M16x2	20	M16x1.5	22	5/8-18	20	5/8-18	22	3/4-16	30	20	8	12	20	8	19	21
50	28	M20x2.5	24	M20x1.5	28	3/4-16	24	3/4-16	28	7/8-14	35	24	10	16	25	9	24	27
63	36	M27x3	30	M27x2	36	1-14	30	1-14	36	1 1/4-12	45	28	12	22	33	11	32	35

**Rod End Dimensions
Thread Style 4**

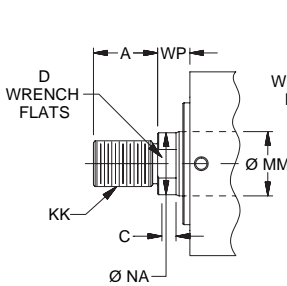

Thread Style 8

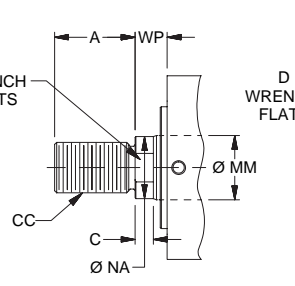

Thread Style 9

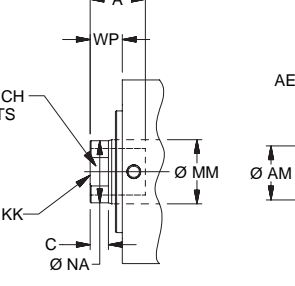

Style 55

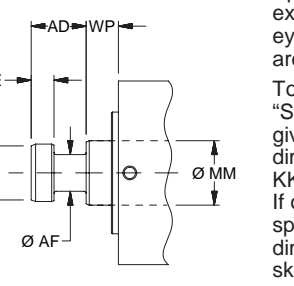

"Special" Thread Style 3

Special thread, extension, rod eye, blank, etc. are also available. To order, specify "Style 3" and give desired dimensions for KK, A, & WP. If otherwise special furnish dimensional sketch.

Suggested Machining for Mounting Series CHD Styles C & CN Cylinders

The drawings and dimensions can be used as a suggested guide for preparing the mounting interface for a mounting style C or CN cylinder. Take care to note that the keyway location varies between top threaded port and bottom manifold port types. The KA keyway location is for top ports only and should not be

used for manifold ports. And, the KM keyway location is for bottom manifold ports and should not be used for top threaded ports. Also the XS rod dimension applies only to the C mount and the XN rod dimension applies only to the CN mount.

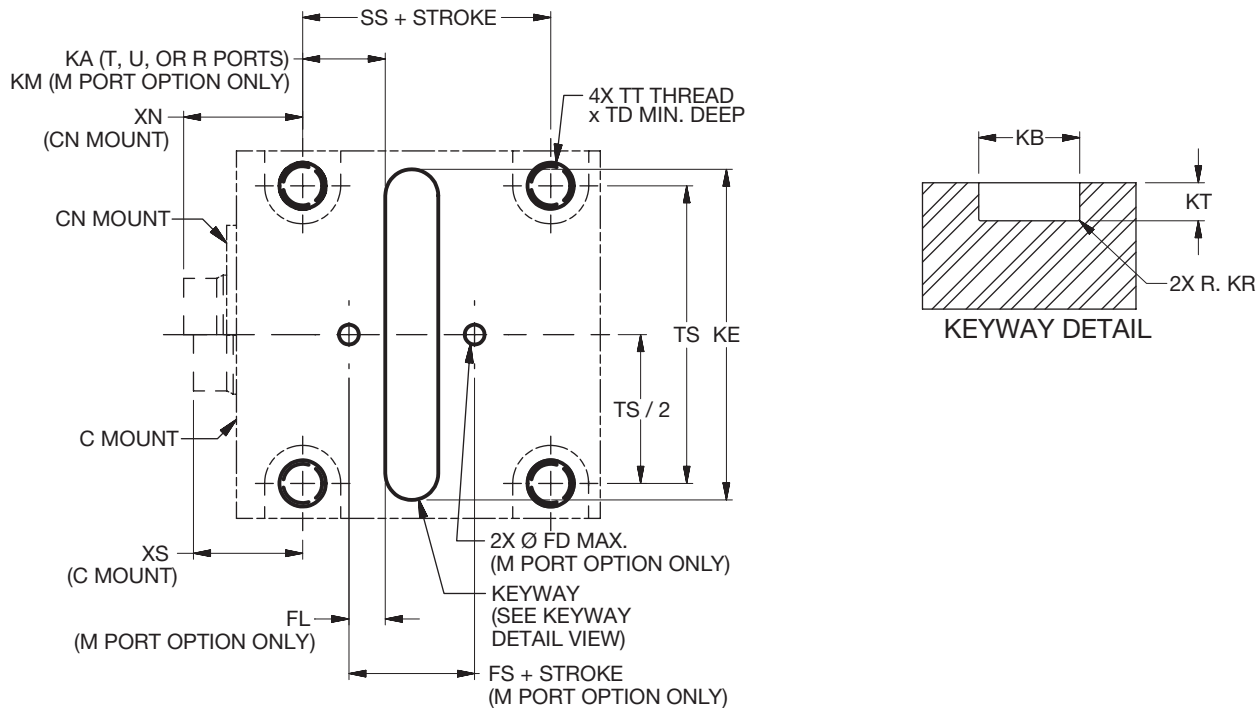

Machining Interface Dimensions

Bore Ø	FD ²	FL ²	KA ¹	KB	KE	KM ²	KR	KT	TD	TS	TT	XN ³	XS ³	Add Stroke	
														FS ²	SS
25	3	7.8	8.5	8 ^{-0.043}	45 ^{+0.5}	8.5	0.16 ^{+0.09}	4 ^{+0.2}	14	39	M6x1-6H	26	23	13.5	24.5
32	3	9.5	8	12 ^{-0.043}	63 ^{+0.5}	8	0.25 ^{+0.15}	5 ^{+0.2}	16	56	M8x1.25-6H	33	30	14	24
40	5	9	8	12 ^{-0.043}	70 ^{+0.5}	8	0.25 ^{+0.15}	5 ^{+0.2}	20	62	M10x1.5-6H	33	30	17	23
50	6	12	9	14 ^{-0.043}	80 ^{+0.5}	13	0.25 ^{+0.15}	5.5 ^{+0.2}	22	74	M12x1.75-6H	34	31	18	27
63	6	11	11	16 ^{-0.043}	100 ^{+0.5}	15.5	0.25 ^{+0.15}	6 ^{+0.2}	24	90	M14x2-6H	36	33	18	32

¹ KA keyway location is for top ports only - do not use for 'M' manifold port option.

² KM keyway location, FD flow hole Ø and FL / FS flow hole locations apply to 'M' manifold port option only.

³ XS dimension is used for C mount; XN dimension is used for CN mount.

Mounting Hardware

Bore Ø	Nominal Key Dimensions	Mounting SHCS ⁴
25	8 x 7 x 45	M6 x 50
32	12 x 8 x 63	M8 x 60
40	12 x 8 x 70	M10 x 70
50	14 x 9 x 80	M12 x 80
63	16 x 10 x 100	M14 x 95

⁴ Customer supplied (4x)

Minimum Rod Extension

Double rod cylinders with Style 9 on V notch side of cylinder

When a rod end Style 9 is specified on the V notch side of a double rod cylinder, a minimum $W + \text{Stroke}$ dimension is required. This bore and stroke dependent value is shown in the following table.

Bore Ø	Minimum W + Stroke	For Strokes Equal-to or Less-than
20	18	10
25	23	15
32	25	15
40	30	20
50	31	20
63	38	25
80	42	25
100	51	25

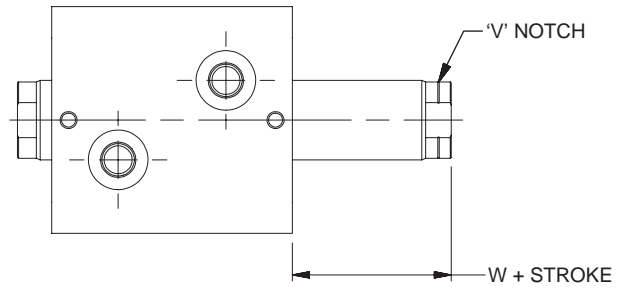

Style 3 (special) rod ends with female thread depth equal to the standard A dimension are also subject to this minimum. For deeper threads, the minimum $W + \text{Stroke}$ will increase by the depth increase beyond the standard A dimension. No other rod end styles have this limitation.

B

PL-2

PH-2

PH-3

PHX

SHM

CHE/CHD

Cylinder Mounting

Always mount Series CHE & CHD cylinders using high tensile alloy steel socket head screws and torque them to the values shown. In addition to bolts, styles C, CA & CN cylinders should be keyed to the mounting surface with a thrust key, utilizing the groove provided in the

cylinder body or mounting bracket. Bolt kits for T, TN, and TR mounts are offered and can be specified by kit part numbers on the next page. Refer to CHE or CHD mounting style pages for bore and mounting availability.

Mounting Bolt Torques

Series	Bore Ø	Metric Mounting Bolts			Inch Mounting Bolts		
		Mount	Size	Torque (N-m)	Mount	Size	Torque (lb-ft)
CHE	20	T, TN, TR	M5x0.8	4.5 - 4.7	T, TN, TR	#10-32	3.2 - 3.4
	25	T, TN, TR	M5x0.8	4.5 - 4.7	T, TN, TR	#10-32	3.2 - 3.4
	32	T, TN, TR	M6x1	7.5 - 7.9	T, TN, TR	1/4-28	5.6 - 5.9
	40	T, TN, TR	M8x1.25	18 - 19	T, TN, TR	5/16-24	13 - 14
	50	T, TN, TR	M10x1.5	35 - 37	T, TN, TR	3/8-24	25 - 26
	63	T, TN, TR	M12x1.75	60 - 63	T, TN, TR	1/2-20	47 - 49
	80	T, TN, TR	M14x2	100 - 105	T, TN, TR	1/2-20 ¹	70 - 73
						9/16-18	75 - 79
CHD	20	T, TN, TR M, MN, MR	M5x0.8	6.8 - 7.1	T, TN, TR A, AN, AR	#10-32	4.7 - 4.9
	25	T, TN, TR M, MN, MR	M5x0.8	6.8 - 7.1	T, TN, TR A, AN, AR	#10-32	4.7 - 4.9
	32	T, TN, TR M, MN, MR	M6x1	11 - 12	T, TN, TR A, AN, AR	1/4-28	8.3 - 8.7
	40	T, TN, TR M, MN, MR	M8x1.25	27 - 28	T, TN, TR A, AN, AR	5/16-24	20 - 21
	50	T, TN, TR M, MN, MR	M10x1.5	55 - 58	T, TN, TR A, AN, AR	3/8-24	38 - 40
	63	T, TN, TR M, MN, MR	M12x1.75	90 - 95	T, TN, TR A, AN, AR	1/2-20	70 - 73
	80	T, TN, TR M, MN, MR	M14x2	150 - 158	T, TN, TR	1/2-20 ¹	70 - 73
					A, AN, AR	9/16-18	110 - 115
CHE & CHD	20	J, H	M5x0.8	6.8 - 7.1	J, H	#10-32	4.7 - 4.9
	25	J, H	M5x0.8	6.8 - 7.1	J, H	#10-32	4.7 - 4.9
	32	J, H	M6x1	11 - 12	J, H	1/4-28	8.3 - 8.7
	40	J, H	M10x1.5	55 - 58	J, H	3/8-24	38 - 40
	50	J, H	M12x1.75	90 - 95	J, H	1/2-20	70 - 73
	63	J, H	M14x2	150 - 158	J, H	9/16-18	110 - 115
	80	J, H	M16x2	230 - 240	J, H	5/8-18	170 - 178
	100	J, H	M20x2.5	450 - 475	J, H	3/4-16	315 - 330
CHE & CHD	20	CA	M5x0.8	6.8 - 7.1	CA	#10-32	4.7 - 4.9
	25	C, CN, CA	M6x1	11 - 12	C, CN, CA	1/4-28	8.3 - 8.7
	32	C, CN, CA	M8x1.25	27 - 28	C, CN, CA	5/16-18	20 - 21
	40	C, CN, CA	M10x1.5	55 - 58	C, CN, CA	3/8-18	38 - 40
	50	C, CN, CA	M12x1.75	90 - 95	C, CN, CA	1/2-20	70 - 73
	63	C, CN, CA	M14x2	150 - 158	C, CN, CA	9/16-18	110 - 115
	80	CA	M16x2	230 - 242	CA	5/8-18	170 - 178
	100	CA	M20x2.5	450 - 475	CA	3/4-16	315 - 330

¹ When using 1/2" socket head cap screws with 80mm T mount, flat washers are required; flat washer OD must be .866" ±.020 (22mm ±0.5).

Mounting Bolt Kits for Series CHE & CHD – Styles T, TN & TR
(Kits include four bolts.)

Bore Ø	Bolt Size	Bolt Length	A Thread Length ¹	Kit Part Number
20	M5x0.8	45mm + Stroke	7.4mm	CHEB020 ²
25	M5x0.8	50mm + Stroke	10.4mm	CHEB025 ²
32	M8x1	55mm + Stroke	10.5mm	CHEB032 ²
40	M8x1.25	60mm + Stroke	13.6mm	CHEB040 ²
50	M10x1.5	65mm + Stroke	15.8mm	CHEB050 ²
63	M12x1.75	70mm + Stroke	16.0mm	CHEB063 ²
80	M14x2	85mm + Stroke	22.2mm	CHEB080 ²
100	M16x2	105mm + Stroke	26.5mm	CHEB100 ²

¹ For intermediate stroke lengths the 'A' exposed thread length will be therefore increased by the difference between the actual stroke and the next longer 5mm bolt stroke length increment.

² The last three digits of the kit part number are to be supplied as the cylinder stroke in 5mm increments. When specifying a bolt kit for intermediate stroke lengths, use the next longer 5mm stroke increment.

E.g. Kit number for 20mm bore, 35mm stroke – CHEB020035
 Kit number for 50mm bore, 72mm stroke – CHEB050075

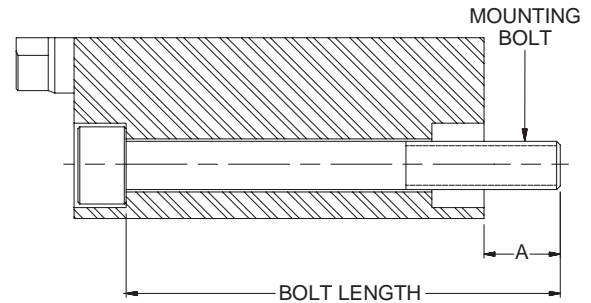

B

PL-2
 PH-2
 PH-3
 PHX
 SHM
CHE/CHD

Parts Identification Drawing – Standard Piston

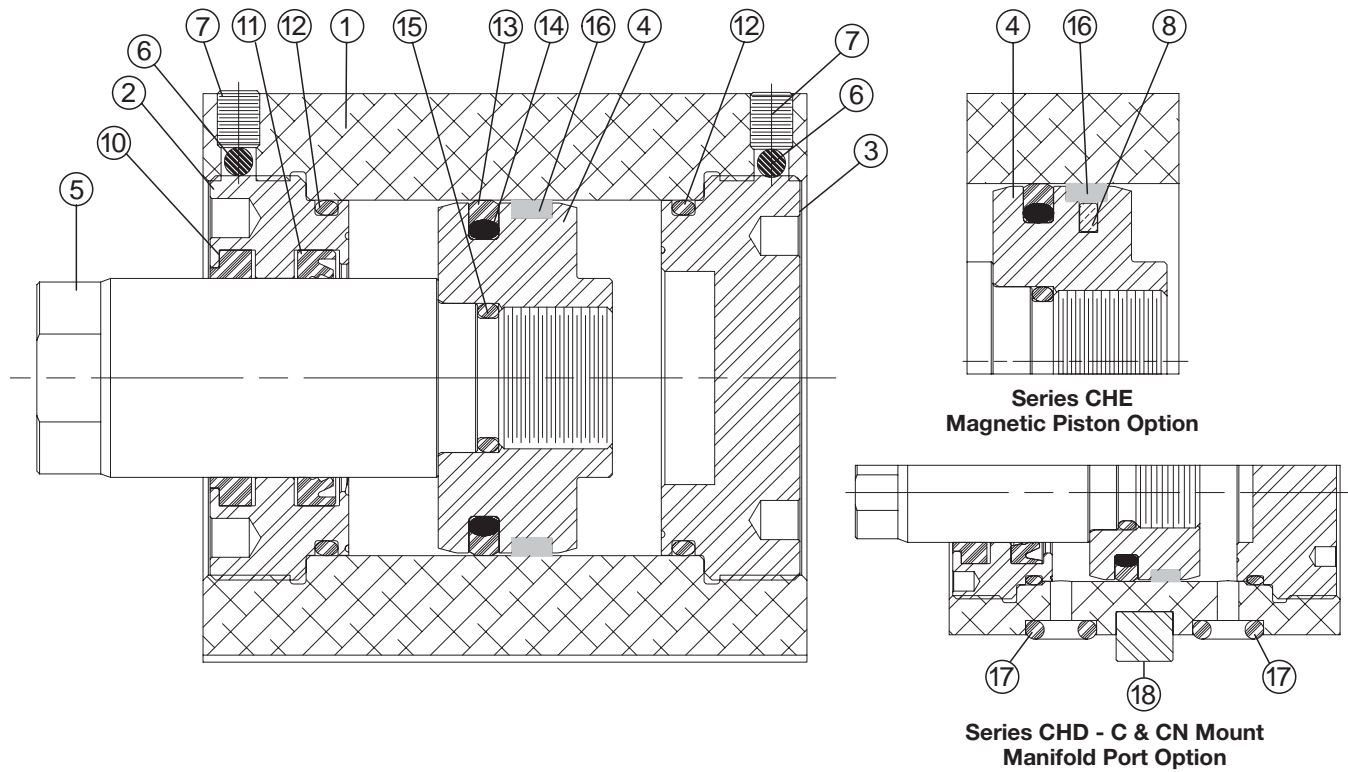

Item No.	Description	Material	Item No.	Description	Material	
					Standard	Fluorocarbon
1	Cylinder Body - CHE	Aluminum Alloy (Hard Anodized)	10	Rod Wiper	PUR	Fluorocarbon
	Cylinder Body - CHD	Steel	11	Rod Seal	PUR	Fluorocarbon
2	Gland	Nodular Iron or Bronze	12	End Seal	PUR	Fluorocarbon
3	Cap	Nodular Iron or Bronze	13	Piston Seal	PUR	Filled PTFE
4	Piston – Standard	Nodular Iron	14	PS Energizer	NBR	Fluorocarbon
	Piston – with Magnet	Aluminum Alloy				
5	Piston Rod	Carbon Steel (Hard Chrome Plated)	15	Piston-to-Rod o-ring	PUR	Fluorocarbon
6	Ball	Nylon	16	Piston Wear Band	Glass-reinforced nylon	Glass-reinforced nylon
7	Set Screw	Alloy Steel				
8	Magnet	Sintered NdFeB ¹	17	Manifold Port Seal	PUR	Fluorocarbon
			18	C & CN Mount Key	Steel	

¹Neodymium Iron Boron

Seal Kits For Series CHE & CHD

See Standard Specifications Page for fluid and temperature compatibility. Cylinder gland and cap are threaded into the cylinder body. To service rod seal, rod wiper, piston seal, or end seals the gland or cap must be removed. Spanner holes in the gland and cap are available for the purpose of removing and installing

these components. Be sure to torque the gland or cap to the specifications below and replace the nylon ball and set screw to further lock them in place. Refer to CHE & CHD mounting style pages for Bore and Rod Diameter availability.

Rod Gland and Rod Seal Kits for Series CHE & CHD

Rod Ø	Rod Gland (w/o pilot ¹) Kits		Rod Seal Kits	
	Class 1	Class 5	Class 1	Class 5
	Consists of 1 ea. of items #2, 6, 10, 11, & 12		Consists of 1 ea. of items #6, 10, 11, & 12	
12	A63430A12	A63430B12	A63430C12	A63430D12
14	A63430A14	A63430B14	A63430C14	A63430D14
18	A63430A18	A63430B18	A63430C18	A63430D18
22	A63430A22	A63430B22	A63430C22	A63430D22
28	A63430A28	A63430B28	A63430C28	A63430D28
36	A63430A36	A63430B36	A63430C36	A63430D36
45	A63430A45	A63430B45	A63430C45	A63430D45
56	A63430A56	A63430B56	A63430C56	A63430D56

¹ Pilot gland is required for AN, CA, CN, J, MN and TN mounting styles. For Gland Kit with pilot change the '0' to a 'P' before the 'A' or 'B'. For example: A6343PA12.

Complete Seal Kits for Series CHE & CHD

Bore Ø	Class 1	Class 5	Gland & Cap Torque Specifications			
	Consists of 1 ea. of items #10, 11, 13, 14, 16 & 2 ea. of items #6 & 12		Series CHE		Series CHD	
	20	A63440A20	A63440B20	21 - 22 N-m	190 - 199 lb-in	34 - 35 N-m
25	A63440A25	A63440B25	41 - 43 N-m	30 - 31 lb-ft	61 - 64 N-m	45 - 47 lb-ft
32	A63440A32	A63440B32	81 - 85 N-m	60 - 63 lb-ft	129 - 135 N-m	95 - 99 lb-ft
40	A63440A40	A63440B40	156 - 163 N-m	115 - 120 lb-ft	230 - 241 N-m	170 - 178 lb-ft
50	A63440A50	A63440B50	258 - 270 N-m	190 - 199 lb-ft	434 - 455 N-m	320 - 336 lb-ft
63	A63440A63	A63440B63	434 - 455 N-m	320 - 336 lb-ft	847 - 889 N-m	625 - 656 lb-ft
80	A63440A80	A63440B80	847 - 889 N-m	625 - 656 lb-ft	1695 - 1779 N-m	1250 - 1312 lb-ft
100	A63440A00	A63440B00	1695 - 1779 N-m	1250 - 1312 lb-ft	-	-

**Spanner Hole Dimensions
Gland & Cap Spanners**

Bore Ø	CC Ø	DD	FF Ø	TH	TP
20	2.75	2.75	22	-	-
25	3.25	3.25	25	-	-
32	4.25	4.25	30	M3x0.5 - 6H	6
40	5.25	5.25	35	M4x0.7 - 6H	7
50	6.38	6.25	45	M5x0.8 - 6H	7
63	8.38	8.25	55	M6x1 - 6H	8
80	10.50	10.50	70	M8x1.25 - 6H	9
100	10.50	10.50	85	M8x1.25 - 6H	9

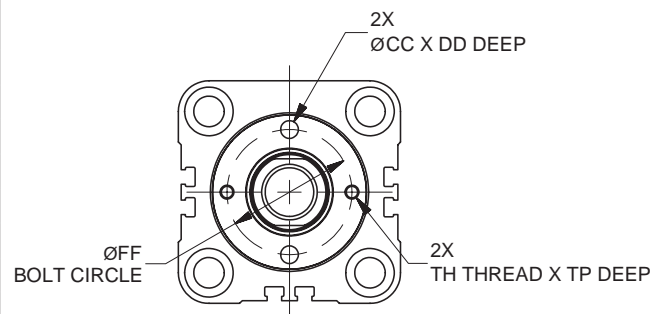

Notes

Section C Overview

Section C – Hydraulic and Pneumatic Cylinders

Schrader Bellows offers you the widest range of Hydraulic and Pneumatic Cylinder Modifications and Options...all available to meet your particular cylinder design requirements of today...and tomorrow. We have a section that lets you “customize” cylinders to fit your

application and help reduce your operating costs. At Schrader Bellows we’re ready to give you any and all the technical assistance you need to provide you with the modified standard cylinder design you need to meet your requirements.

Custom Modifications and Innovations

Table of Features and Modifications Available on Schrader Bellows Hydraulic and Pneumatic CylindersPage 2

Linear Alignment CouplersPages 3 - 4

End of Stroke Proximity Sensors Pages 5 - 14

Counter Balance CylinderPage 15

PC, PD and PS Series Intensifiers Pages 17 - 24

F02 Series Air-Oil Tanks..... Pages 25 - 27

Cylinder Parts Identification and Seal Kit Data

Series CHE/CHD Pages 30-31

PA-2, PL-2, PH-2 Series Pages 32-34

PA-2, PL-2 Series Pages 35-36

PN SeriesPage 37

PH-2 Series Pages 38-39

PH-3 Series Pages 40-43

PL-2 SeriesPage 44

SHM Series Pages 45-46

Series SH/SHG Pages 47-48

Application Engineering Data

Hydraulic and Pneumatic Cylinders Application Engineering Data..... Pages 49-102

Cylinder Safety Guide Pages 106-107

Offer of SaleInside Back Cover



Feature	Hydraulic Series						Pneumatic Series	
	PL-2	PH-2	PH-3	CHE	SH/SHG	SHM	PA-2	NC9
Non-Lube (N)* (1)							●	●
High Water Content Fluids	●	●	●		●	●		
Special Piston Rod Ends (1)	●	●	●	●	●	●	●	●
Rod End Threads 2 X Std. Length (1)	●	●	●	●	●	●	●	●
Port Relocation (2)	●	●	●		●	●	●	●
Extra Ports (2)	●	●	●		●	●	●	●
SAE "O" Ring Ports (2)	●	●	●	●	●	●	●	●
Oversize Port (2)	●	●	●		●	●	●	●
Mounting Combinations (2)	●	●	●	●	●	●	●	●
Stroke Adjusters (2)	●	●	●		●	●	●	
Spring Return (2)	●	●	●		●	●	●	●
Spring Extend (1)	●	●	●		●	●	●	
Water Service (2)	●	●	●		●	●	●	●
Hi-Load Piston (1)		●	●		●	●		
Fluorocarbon Seals (2)	●	●	●	●	●	●	●	●
Rod End Boots (2)	●	●	●		●	●	●	
Manifold Ports (2)	●	●	●			●	●	
Metallic Rod Wiper (2)	●	●	●		●	●	●	
Gland Drain (2)	●	●	●			●		
Air Bleeds (2)	●	●	●		●	●		
Thrust Key (2)	●	●	●	●	●	●	●	●
Spherical Bearings (1)	●	●				●	●	●
EPS-5, 6 & 7 and CLS1 & 4 Proximity Switches (2)	●	●	●			●	●	●
Flange Coupling Piston Rod End (2)	●	●	●	●	●		●	●

*Modification suffix ie: PN.

(1) See Catalog Section for details.

(2) See Application Engineering Section for details.

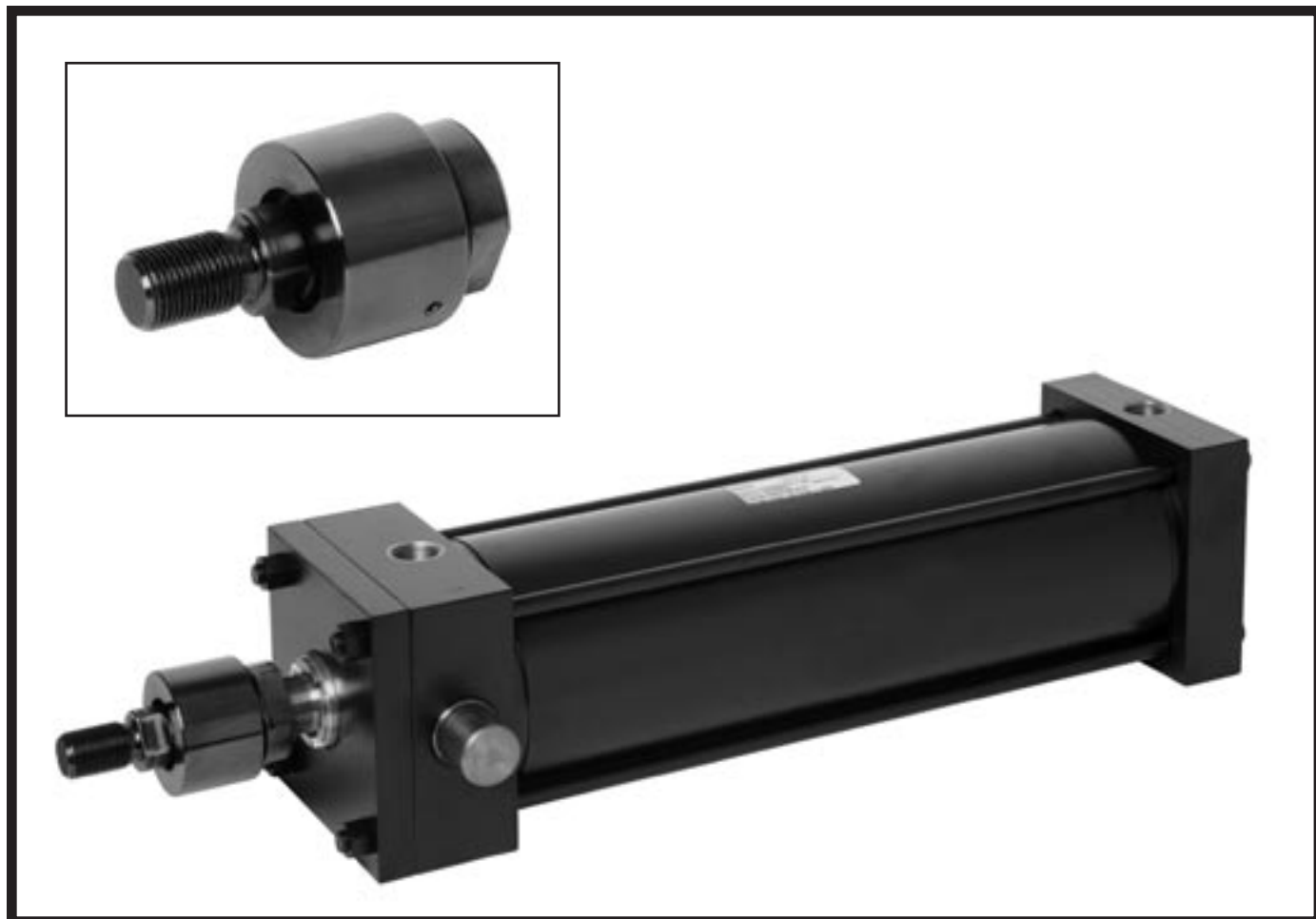

- Simplify Cylinder Installation
- Reduce Assembly Time
- Increase Cylinder Bearing and Seal Life
- Reliable Performance in “Push”
and “Pull” Applications

Linear Alignment Couplers are available in 12 standard thread sizes...

Cost Saving Features and Benefits Include...

- Maximum reliability for trouble-free operation, long life and lower operating costs
- Increased cylinder life by reducing wear on Piston and Rod bearings
- Simplifying Cylinder installation and reducing assembly costs
- Increase Rod Bearing and Rod Seal life for lower maintenance costs

Alignment Coupler

See Table 1 for Part Numbers and Dimensions

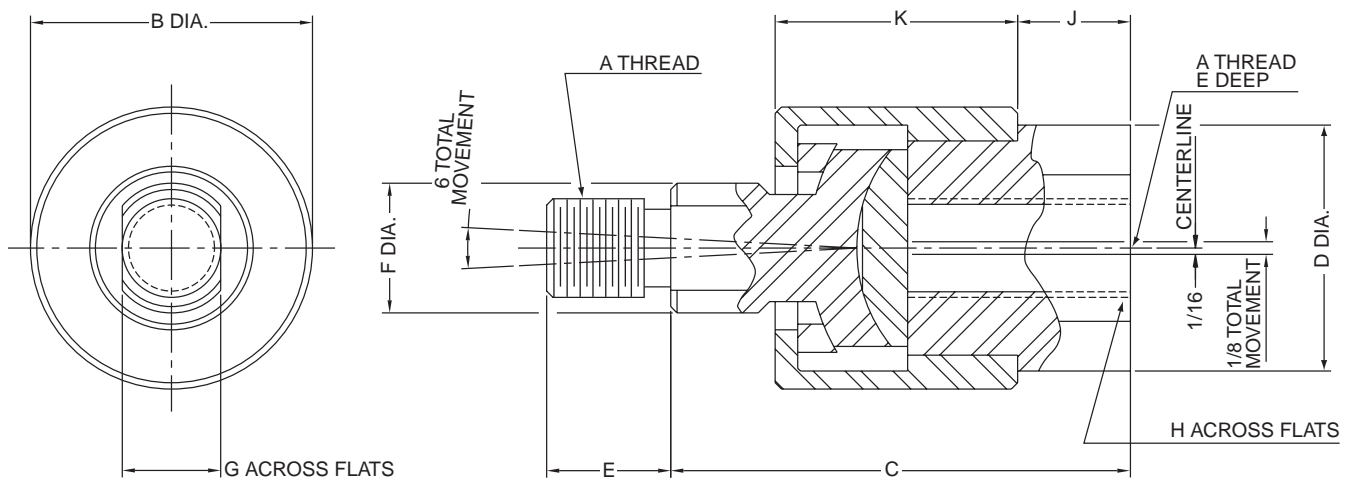

Table 1 — Part Numbers and Dimensions

Part No.	A	B	C*	D	E	F	G	H	J	K	Max. Pull Load (lbs.)	Approx. Weight (lbs.)
1347570031	5/16-24	1 1/8	1 3/4	15/16	1/2	1/2	3/8	3/4	3/8	15/16	1200	.35
1347570038	3/8-24	1 1/8	1 3/4	15/16	1/2	1/2	3/8	3/4	3/8	15/16	2425	.35
1347570044	7/16-20	1 3/8	2	1 1/8	3/4	5/8	1/2	7/8	3/8	1 3/32	3250	.55
1347570050	1/2-20	1 3/8	2	1 1/8	3/4	5/8	1/2	7/8	3/8	1 3/32	4450	.55
1347570063	5/8-18	1 3/8	2	1 1/8	3/4	5/8	1/2	7/8	3/8	1 3/32	6800	.55
1347570075	3/4-16	2	2 5/16	1 5/8	1 1/8	15/16	3/4	1 5/16	7/16	1 9/32	9050	1.4
1347570088	7/8-14	2	2 5/16	1 5/8	1 1/8	15/16	3/4	1 5/16	7/16	1 9/32	14450	1.4
1347570100	1-14	3 1/8	3	2 3/8	1 5/8	1 7/16	1 1/4	1 7/8	3/4	1 25/32	19425	4.8
1347570125	1 1/4-12	3 1/8	3	2 3/8	1 5/8	1 7/16	1 1/4	1 7/8	3/4	1 25/32	30500	4.8
1337390125	1 1/4-12	3 1/2	4	2	2	1 1/2	1 1/4	1 11/16	3/4	2 1/2	30500	6.9
1337390150	1 1/2-12	4	4 3/8	2 1/4	2 1/4	1 3/4	1 1/2	1 15/16	7/8	2 3/4	45750	9.8
1337390175	1 3/4-12	4	4 3/8	2 1/4	2 1/4	1 3/4	1 1/2	1 15/16	7/8	2 3/4	58350	9.8
1337390188	1 7/8-12	5	5 5/8	3	3	2 1/4	1 15/16	2 5/8	1 3/8	3 3/8	67550	19.8

How to Order Linear Alignment Couplers — When ordering a cylinder with a threaded male rod end, specify the coupler of equal thread size by part number as listed in Table 1, i.e.; Piston Rod “KK” or “CC” dimension is 3/4" - 16", specify coupler part number 1347570075.

Cylinder End-of-Stroke Proximity Sensors

**For Series PA-2, PH-2, PL-2,
PH-3 and SHM Cylinders**



“EPS” Style Inductive Sensors
For General Industrial AC and DC Applications

“CLS” Style Magnetic Sensors
For Extreme Temperature Applications

All Sensors Are:
Non-Contacting
Water Resistant
Weld-Field Immune
Shock and Vibration Resistant
Flange-Mounted to Cylinder End Caps

EPS 7 & 6 Sensors

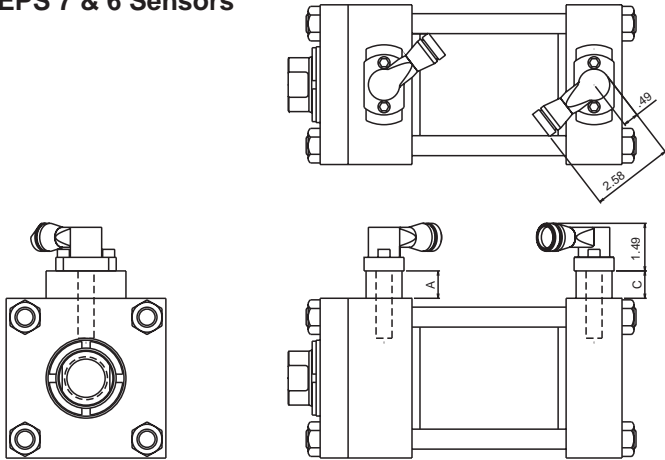

CLS 1 & 4 Sensors

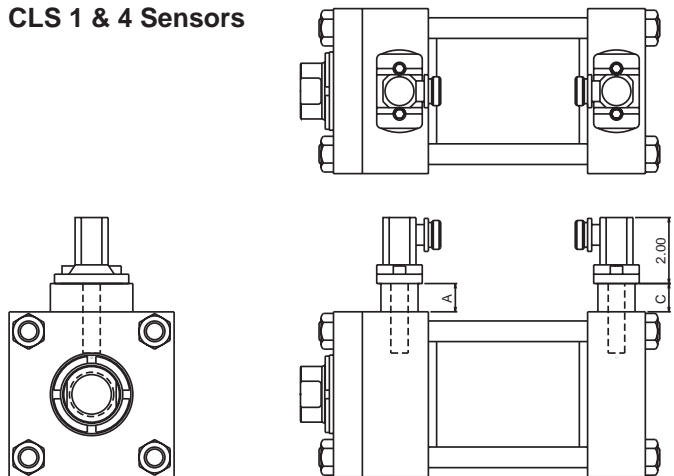

Series and Parallel Wiring

When Schrader Bellows EPS-6 or 7 proximity switches are used as inputs to programmable controllers the preferred practice is to connect each switch to a separate input channel of the PC. Series or parallel operations may then be accomplished by the internal PC programming.

Schrader Bellows EPS-6 or 7 switches may be hard wired for series operation, but the voltage drop through the switches (see specifications) must not reduce the available voltage below what is needed to actuate the load.

Schrader Bellows EPS-6 or 7 switches may also be hard wired for parallel operation. However, the leakage current of each switch will pass through the load. The total of all leakage currents must not exceed the current required to actuate the load. In most cases, the use of two or more EPS-6 or 7 switches in parallel will require the use of a bypass (shunt) resistor.

Series	A max.	C max.
PH-2, PH-3 1.5"-8" bores	.86"	1.75"
PL-2	1.55"	1.05"
PA-2	1.55"	1.30"
SHM	1.19"	1.05"

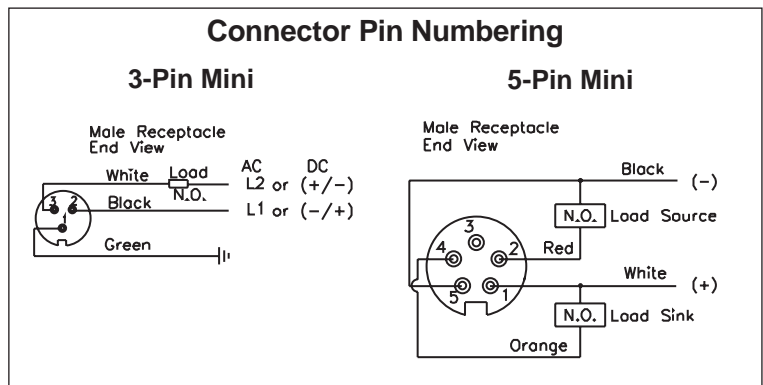

Specifications				
Style:	EPS-7	EPS-6	CLS-1	CLS-4
Code Designator:	H	D	F	B
Description:	Economical, General Purpose, 2 wire device, primarily for AC applications, not suitable for 24 VDC applications. Also for automotive industry applications.	Economical, General Purpose, 3 wire, DC sensor, dual output: sinking and sourcing	Functional replacement for AB (Mechanical) Limit Switches in many applications, or where customer needs NC contacts, zero leakage, zero voltage drop, higher or lower load current than EPS-style.	Functional replacement for AB (Mechanical) Limit Switches in many High Temperature applications, or where customer needs NC contacts, zero leakage, zero voltage drop, higher or lower load current than EPS-style.
Supply Voltage:	20 to 250 VAC/DC	10 to 30 VDC	24 to 240 VAC/DC	24 to 240 VAC/DC
Load Current, min:	8 mA	NA	NA	NA
Load Current, max:	300 mA	200 mA	4 AMPS @ 120 VAC 3 AMPS @ 24 VDC	4 AMPS @ 120 VAC 3 AMPS @ 24 VDC
Leakage Current:	1.7 mA, max.	10 micro amps max.	-	-
Voltage Drop:	7 V, max.	2 VDC max.	NA	NA
Operating Temperature:	-14° to +158° F	-14° to +158° F	-40°F to +221° F	-40° F to +400° F
Sensor Type:	Inductive proximity	Inductive proximity	Non-contacting magnetically actuated	Non-contacting magnetically actuated
Part Number:	148897****	148896****	148275****	149109****
Part Number Suffix **** :	**** 4-digit suffix indicates probe length: 0125=1.25", 0206=2.06", 0288=2.875", 0456=4.562"			
Connection:	3 pin mini	5 pin mini	3 pin mini	144" PTFE Coated Flying Leads with 1/2" conduit hub
Enclosure Rating:	IEC IP67	IEC IP67	NEMA 1, 2, 3, 4, 4x, 5, 6, 6P, 11, 12, 12K, 13	NEMA 1, 2, 3, 4, 4x, 5
LED indication:	Yes	Yes	No	No
Short Circuit Protection:	Yes	Yes	No	No
Weld Field Immunity:	Yes	Yes	Yes	Yes
Output:	2 wire, Normally Open with leakage current	Dual output: DC Sinking and DC Sourcing, user selectable via wiring	SPDT (Single Pole Double Throw), Normally Open/Normally Closed, Form C	SPDT (Single Pole Double Throw), Normally Open/Normally Closed, Form C
Approvals/Marks:	CE, UL, CSA	CE, UL, CSA	UL or CSA†	UL or CSA†
Make/Break Location	0.125" from end of stroke, typical. Tolerance is 0/- .125"			
Wiring Instructions:	Pin 1: AC Ground (Green) Pin 2: Output (Black) Pin 3: AC Line (White)	Pin 1) +10 to 30 VDC (White) Pin 2) Sourcing Output (Red) Pin 3) Grounded (not connected or required) Pin 4) Sinking Output (Orange) Pin 5) DC Common (Black)	Pin 1: Common (Green) Pin 2: Normally Closed (Black) Pin 3: Normally Open (White)	Common: (Black) Normally Open: (Blue) Normally Closed: (Red)
Standard Cable: 6'	0853550006	0859170006	0853550006	-
Standard Cable: 12'	0853550012	0859170012	0853550012	-
Cable: 6', Right Angle	0875470006	-	0875470006	-

†CSA available upon request – consult factory



Schrader Bellows EPS proximity switches may be ordered on Series PA-2, PN, PL-2, PH-2, PH-3, and SHM cylinders as follows:

- 1) Complete the basic cylinder model number.
- 2) Place an "S" in the model number to denote switches and/or special features.

3) Mounting styles MT1, MT2, ME5, MF5, MF6 should be used with caution because of possible mounting interferences. See the following page.

4) Special modifications to cylinders other than switches must have a written description.

How to Specify EPS Switches

5) Specify letter prefix "H" for EPS-7, "D" for EPS-6, and "F" for CLS-1, or "B" for CLS-4, then fill in the four blanks specifying port location, switch orientation and actuation point for both head and cap. If only one switch is used, place "XXXX" in the unused blanks.

Example = H13CGG-XXXX denotes a switch on the head end only, EPS-7

Example = XXXX-B42BGG denotes a switch on the cap end only, CLS-4

Head End

H	1	3	A	GG
Specify: "H" = EPS-7 "D" = EPS-6 "F" = CLS-1* "B" = CLS-4* "N" = Prepared for switches only	Port Location See Figure 1.	Switch Location See Figure 1.	Switch Orientation See Figure 2 for EPS-7 and EPS-6 only.	Actuation Point GG = End of Stroke FF = Stroke to Go; See pages 10-12 for stroke remaining.

Cap End

4	2	B	GG
Port Location See Figure 1.	Switch Location See Figure 1.	Switch Orientation See Figure 2 for EPS-7 and EPS-6 only.	Actuation Point GG = End of Stroke FF = Stroke to Go; See pages 10-12 for stroke remaining.

* CLS-1 and CLS-4 switches are not available on the head end of 1 1/2" bore with 1" rod and 2" bore with 1 3/8" rod.

Note: All specified switch and port locations are as seen from rod end of cylinder.

Figure 1

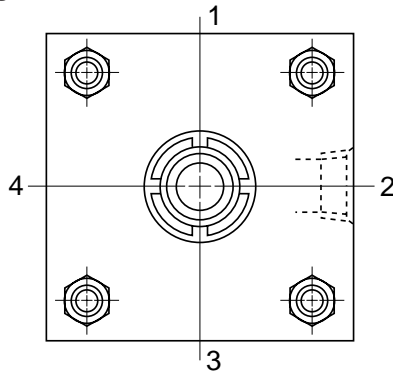
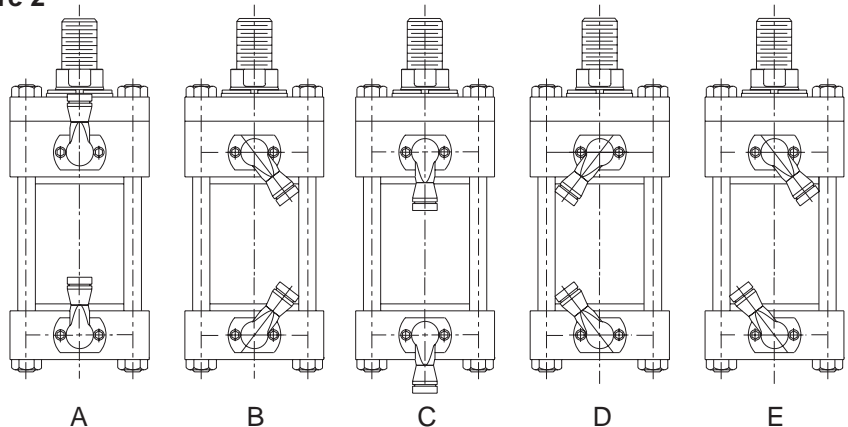

Figure 2



These pages contain mounting information for EPS and CLS Style Proximity Switches by bore and rod combination.

Switches, spacers and mounting bolts have each been assigned a code that can be found in Tables 2, 3 and 4.

The components of a complete switch assembly may be identified by cross referencing these codes with the part numbers in Tables 5, 6 and 7.

**EPS-6 & 7 Heavy Duty
Industrial & Automotive Applications**

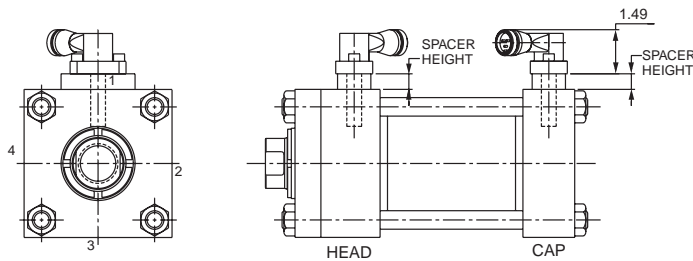

**CLS-1 & 4 Switches
Extreme Temperature Applications**

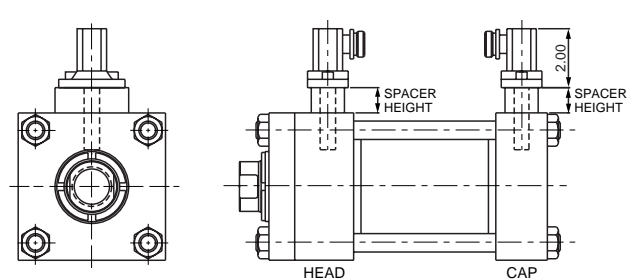

Table 1 - Available Mounting Positions for EPS- 6, 7 & CLS 1, 4

EPS 6,7 & CLS 1, 4		Switch Locations for PA-2, PN, PL-2, PH-2, PH-3, SHM Series									
MOUNTING STYLES											
Bores sizes (inches):		1.5	2	2.5	3.25	4	5	6	7	8	10
MHP bores sizes (mm):		40	50	63	80	100	125	160	-	200	-
MT4, MX0, MX1, MX2, MX3, MP1	HEAD	1,2,3,4	1,2,3,4	1,2,3,4	1,2,3,4	1,2,3,4	1,2,3,4	1,2,3,4	1,2,3,4	1,2,3,4	1,2,3,4
	CAP	1,2,3,4	1,2,3,4	1,2,3,4	1,2,3,4	1,2,3,4	1,2,3,4	1,2,3,4	1,2,3,4	1,2,3,4	1,2,3,4
MF1, ME5, MT1 (see note 3)	HEAD	1,3	1,3	1,3	1,3	1,3	1,3	1,3	1,3	1,3	1,3
	CAP	1,2,3,4	1,2,3,4	1,2,3,4	1,2,3,4	1,2,3,4	1,2,3,4	1,2,3,4	1,2,3,4	1,2,3,4	1,2,3,4
MF2, ME6, MT2	HEAD	1,2,3,4	1,2,3,4	1,2,3,4	1,2,3,4	1,2,3,4	1,2,3,4	1,2,3,4	1,2,3,4	1,2,3,4	1,2,3,4
	CAP	1,3	1,3	1,3	1,3	1,3	1,3	1,3	1,3	1,3	1,3
MS2 (see note 2)	HEAD	1	1	1	1	1	1	1,2,4	1,2,4	1,2,4	1,2,4
	CAP	1	1	1	1	1	1	1,2,4	1,2,4	1,2,4	1,2,4
MS4	HEAD	1	1	1,2,4	1,2,4	1,2,4	1,2,4	1,2,4	1,2,4	1,2,4	1,2,4
	CAP	1	1	1,2,4	1,2,4	1,2,4	1,2,4	1,2,4	1,2,4	1,2,4	1,2,4
MF5	HEAD	NA	NA	NA	1,2,3,4	1,2,3,4	1,2,3,4	1,2,3,4	1,2,3,4	1,2,3,4	1,2,3,4
	CAP	1,2,3,4	1,2,3,4	1,2,3,4	1,2,3,4	1,2,3,4	1,2,3,4	1,2,3,4	1,2,3,4	1,2,3,4	1,2,3,4
MF6	HEAD	1,2,3,4	1,2,3,4	1,2,3,4	1,2,3,4	1,2,3,4	1,2,3,4	1,2,3,4	1,2,3,4	1,2,3,4	1,2,3,4
	CAP	NA	NA	NA	1,2,3,4	1,2,3,4	1,2,3,4	1,2,3,4	1,2,3,4	1,2,3,4	1,2,3,4

Note: The electrical connector orientation may be restricted in some cases. Consult the dimensions in the current catalog.

Note 2: On 6" cylinders and larger, and for 160mm and 200mm bores, switches mounted in position 2 or 4 will interfere with the installation and removal of mounting bolts.

Note 3: On 1.5 through 5" Style ME5 cylinders, switches will extend beyond mounting surface of cylinder.

Note 4: Positions 1, 2, 3 and 4 are determined by viewing cylinder from piston rod end and going clockwise.

Table 2 CODES FOR PA-2, PN, PL-2 SERIES CYLINDERS WITH EPS 6, 7 & CLS 1, 4 SWITCHES									
BORE	SERIES	ROD DIA	END-OF-STROKE PROBE LOCATION ("GG" ORDER CODE)	SPACER HEIGHT	SWITCH CODE	SPACER CODE	EPS 6,7 BOLT CODE (1)	CLS 1, 4 BOLT CODE (1)	OPTIONAL STROKE TO GO ("FF" ORDER CODE)
1.5	PA-2 PL-2	0.63	0.59	0.688	1	FK	299	F99	0.44
		1	0.59	0.876	1	1K	399	199	0.44
		CAP	0.63	0.468	1	BK	1D9	9D9	0.17
2	PA-2 PL-2	0.63	0.59	0.579	1	D2	2E9	0E9	0.44
		1.375	0.59	0.829	1	H2	399	199	0.44
		1	0.59	0.688	1	F2	299	F99	0.44
2.5	PA-2 PL-2	CAP	0.63	1.048	2	EG2	499	299	0.17
		0.63	0.63	0.296	1	E	29	F9	0.48
		1.75	0.63	0.796	1	EH	49	29	0.48
		1	0.63	0.421	1	G	39	19	0.48
		1.38	0.63	0.608	1	DF	39	29	0.48
3.25	PA-2 PL-2	CAP	0.63	0.780	2	FG	49	29	0.17
		1	0.88	0.858	2	FH	49	39	0.73
		2	0.56	0.608	1	DF	39	29	0.42
		1.375	0.88	0.249	1	D	2E	FE	0.73
		1.75	0.88	0.421	1	G	39	19	0.73
4	PA-2 PL-2	CAP	0.75	0.546	2	J	39	29	0.34
		1	0.88	0.499	2	H	39	19	0.73
		2.5	0.56	0.546	1	J	39	29	0.42
		1.375	0.88	0.671	2	DG	49	29	0.73
		1.75	0.88	0.858	2	FH	49	39	0.73
5	PA-2 PL-2	2	0.56	0.249	0	D	2E	FE	0.42
		CAP	0.75	0.170	2	C	1D	0D	0.34
		1	0.88	0.796	3	EH	49	39	0.72
		3.5	0.56	0.546	1	J	39	29	0.42
		1.38	0.88	0.170	2	C	2D	FD	0.72
		1.75	0.88	0.358	2	F	29	F9	0.72
		2	0.56	0.546	2	J	39	29	0.42
		2.5	0.56	0.858	2	FH	49	39	0.42
6	PA-2 PL-2	3	0.56	0.296	1	E	29	F9	0.42
		CAP	0.75	0.499	3	H	39	19	0.34
		1.38	1.13	0.499	3	H	39	29	0.98
		4	0.81	0.296	1	E	29	F9	0.66
		1.75	1.13	0.671	3	DG	49	29	0.98
		2	0.81	0.858	3	FH	49	39	0.66
		2.5	0.81	0.358	2	F	29	F9	0.66
		3	0.81	0.608	2	DF	39	29	0.66
7	PA-2	3.5	0.81	0.858	2	FH	49	39	0.66
		CAP	0.75	0.109	3	A	1D	GD	0.34
		1.38	1.13	0	3	NONE	1	G	0.98
		1.75	1.13	0.170	3	C	2D	FD	0.98
8	PA-2 PL-2	2	0.81	0.358	3	F	29	F9	0.66
		3	0.81	0.608	2	DF	39	29	0.66
		3.5	0.81	0.858	2	FH	49	39	0.66
		CAP	0.75	0.109	3	A	1D	GD	0.34
		1.38	1.13	1.171	4	DGH	6B	4B	0.98
		5.5	0.69	0.921	2	GH	5B	3B	0.54
		1.75	1.13	1.358	4	FHH	6B	5B	0.98
		2	0.81	1.546	4	HHJ	7C	6C	0.66
		2.5	0.81	0.170	3	C	2D	FD	0.66
10	PA-2	3	0.81	0.421	3	G	39	19	0.66
		3.5	0.81	0.671	3	DG	49	29	0.66
		4	0.81	0.110	2	A	1D	GD	0.66
		5	0.81	0.671	2	DG	49	29	0.66
		CAP	0.94	0.796	4	EH	49	39	0.63
		1.75	1.38	0.296	4	E	29	F9	1.22
		2	1.06	0.499	4	H	39	19	0.91
		2.5	1.06	0.499	4	EH	49	39	0.91
10	PA-2	3	1.06	1.046	4	DEH	5B	4B	0.91
		3.5	1.06	1.296	4	EHH	6B	5B	0.91
		4	1.06	0	3	NONE	1	G	0.91
		5	0.94	0.421	3	G	39	19	0.79
		5.5	0.94	0.671	3	DG	49	29	0.79
		CAP	0.94	0	4	NONE	1	G	0.53

(1) The first digit of the Bolt Code refers to screws that mount the switch to the cylinder. The second and third digits refer to screws that mount the spacers to the cylinder.

BORE	SERIES	ROD DIA	END-OF-STROKE PROBE LOCATION ("GG" ORDER CODE)	SPACER HEIGHT	SWITCH CODE	SPACER CODE	EPS 6, 7 BOLT CODE (1)	CLS 1, 4 BOLT CODE (1)	OPTIONAL STROKE TO GO ("FF" ORDER CODE)
40	SHM	18	0.875	0.688	1	E3	HPP	LPP	.532
		28	0.875	0.688	1	F3	HPP	LPP	.532
		CAP	0.875	1.048	2	EG3	KPP	UPP	.656
50	SHM	22	0.875	1.188	2	FH3	KPP	UPP	.532
		36	0.875	0.626	1	E3	HPP	LPP	.532
		28	0.875	0.500	1	C3	HNP	WPP	.532
		CAP	0.875	0.829	2	H3	JPP	HPP	.656
63	SHM	28	0.875	0.249	1	D	HN	LN	.500
		45	0.875	0.546	1	J	JP	UP	.500
		36	0.875	0.358	1	F	HP	HP	.500
		CAP	0.875	0.671	2	DG	KP	UP	.656
80	SHM	36	1.125	0.671	2	DG	KP	UP	.500
		56	0.812	0.296	1	E	HN	LN	.500
		45	1.125	0.858	2	FH	KP	UP	.500
		CAP	1.000	0.296	2	E	HP	LP	.656
100	SHM	45	1.125	0.608	2	DF	JP	UP	.500
		70	0.812	0.358	1	F	HP	LP	.500
		56	0.812	0.858	2	FH	KP	JP	.500
		CAP	1.000	0.170	2	C	HN	LN	.656
125	SHM	56	0.812	0.170	2	C	HN	LN	.500
		90	0.812	0.109	1	A	LN	WN	.500
		70	0.812	0.499	2	H	JP	HP	.500
		CAP	1.000	0.421	3	G	JP	HP	.656
160	SHM	70	1.062	0.499	3	H	JP	HP	.500
		110	1.062	0.499	2	H	JP	HP	.500
		90	1.062	0.109	2	A	LN	WN	.500
		CAP	1.312	0.546	4	J	MQ	YQ	.670
200	SHM	90	1.562	0.170	3	C	HN	LN	.670
		140	1.687	0.421	2	G	JP	HP	.670
		110	1.687	0.546	3	J	JP	UP	.670
		CAP	1.937	0.671	4	DG	KP	UP	.670

(1) The first digit of the Bolt Code refers to screws that mount the switch to the cylinder. The second and third digits refer to screws that mount the spacers to the cylinder.

Code	Probe Length (inches)	Schrader Bellows Part Number			
		EPS 6 DC	EPS 7 AC	CLS 1 AC	CLS 4 AC
1	1.250	1488960125	1488970125	1482750125	1491090125
2	2.062	1488960206	1488970206	1482750206	1491090206
3	2.875	1488960287	1488970287	1482750287	1491090287
4	4.562	1488960456	1488970456	1482750456	1491090456
Brand		Pepperl & Fuchs	Pepperl & Fuchs	Topworx	Topworx
Connection		5 Pin Mini	3 Pin Mini	3 Pin Mini	144" PTFE Coated Flying Leads with 1/2" conduit hub
Voltage		10-30 VDC	50-220 VAC/DC	24-240 VAC/DC	24 to 240 VAC/DC
Output		PNP & NPN	Normally Open	SPDT, Form C	SPDT, Form C
Leakage Current		NA	<1.7mA	-	-
Voltage Drop		<.8 VDC	<10 Volts	NA	NA

Table 3									
CODES FOR PH-2 and PH-3 SERIES CYLINDERS WITH EPS 6, 7 & CLS 1, 4 SWITCHES									
BORE	SERIES	ROD DIA	END-OF-STROKE PROBE LOCATION ("GG" ORDER CODE)	SPACER HEIGHT	SWITCH CODE	SPACER CODE	EPS 6, 7 BOLT CODE (1)	CLS 1, 4 BOLT CODE (1)	OPTIONAL STROKE TO GO ("FF" ORDER CODE)
1.5	PH-2	0.63	0.880	0.439	1	A2	1D9	GD9	.422
		1	0.880	0.626	1	E2	299	F99	.422
		CAP	0.937	1.048	2	EG2	499	299	.381
2	PH-2	1	0.880	0.439	1	A2	1D9	GD9	.442
		1.375	0.880	0.579	1	D2	2E9	0E9	.442
		CAP	0.875	0.938	2	DF2	399	299	.319
2.5	PH-2	1	0.880	0.170	1	C	2D	FD	.475
		1.75	0.880	0.546	1	J	39	29	.475
		1.375	0.880	0.358	1	F	39	F9	.475
		CAP	0.875	0.671	2	DG	49	29	.319
3.25	PH-2	1.375	1.125	0.671	2	DG	49	29	.725
		2	0.812	0.249	1	D	2	FE	.417
		1.75	1.125	0.858	2	FH	49	39	.725
		CAP	1.062	0.296	2	E	29	F9	.506
4	PH-2	1.75	1.125	0.608	2	DF	39	29	.725
		2.5	0.812	0.296	1	E	29	F9	.417
		2	0.812	0	1	NONE	1	G	.417
		CAP	1.000	0.170	2	C	2D	FD	.444
5	PH-2	2	0.812	0.858	3	FH	49	39	.417
		3.5	0.812	0.858	2	FH	49	39	.417
		2.5	0.812	0.358	2	F	29	F9	.417
		3	0.812	0.608	2	DF	39	29	.417
		CAP	0.875	0.358	3	F	29	F9	.319
6	PH-2	2.5	1.062	0.671	3	DG	49	29	.663
		4	1.062	0.608	2	DF	39	29	.663
		3	1.062	0.109	2	A	1	GD	.663
		3.5	0.812	0.358	2	F	29	F9	.417
		CAP	1.250	1.749	4	DHHH	8D	6C	.683
7	PH-3	3	1.562	0.421	3	G	39	19	1.162
		5	1.437	0.671	2	DG	49	29	1.037
		3.5	1.562	0.671	3	DG	49	29	1.162
		4	1.062	0.109	2	A	1D	GD	.663
		CAP	1.687	1.421	4	GHH	7B	51	1.117
8	PH-3	3.5	1.812	0.170	3	C	2D	FD	1.412
		5.5	1.687	0.421	2	G	39	19	1.287
		4	1.062	0.421	3	G	39	19	.663
		5	1.437	0.170	2	C	2D	FD	1.037
		CAP	1.687	0.921	4	GH	5B	3B	1.183

(1) The first digit of the Bolt Code refers to screws that mount the switch to the cylinder. The second and third digits refer to screws that mount the spacers to the cylinder.

Table 6 — Spacer Blocks					
Letter Code	Part #	Spacer Height (inches)	Letter Code	Part #	Spacer Height (inches)
A	0854690110	.109	EH	0854690797	.796
B	0854670000	.138	FH	0854690859	.858
C	0854690171	.170	GH	0854690922	.921
D	0854690250	.249	BGG	0854690983	.982
E	0854690297	.296	DEH	0854691047	1.046
F	0854680359	.358	DGH	0854691172	1.171
G	0854690422	.421	EHH	0854691297	1.296
H	0854690500	.499	FHH	0854691359	1.358
J	0854690547	.546	GHH	0854691422	1.421
K	0854660000	.330	HHJ	0854691547	1.546
DF	0854690609	.608	DHHH	0854691750	1.749
DG	0854690672	.671	1	0854680547	.546
EG	0854690719	.718	2	0854820000	.330
FG	0854690781	.780	3*	0875830000	.330

One O-Ring per spacer, Size# 2 - 15, Part Number 0100240003 (Fluorocarbon)

* Used on SHM only

EPS-6 & 7 Heavy Duty Industrial & Automotive Applications

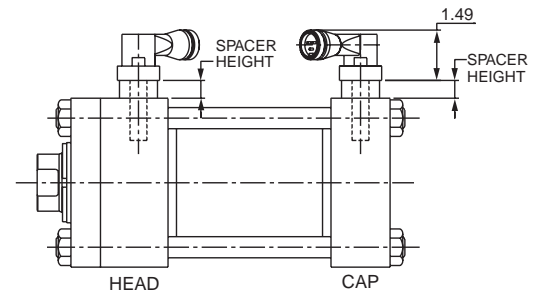
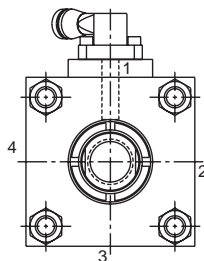

CLS-1 & 4 Extreme Temperature Applications

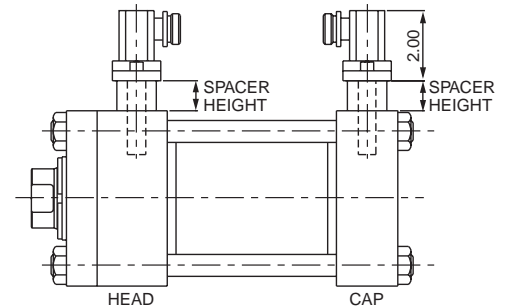
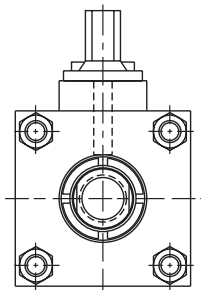

Table 7 — Mounting Bolts

Two mounting bolts are required per switch.

Mounting Bolts for PA-2, PN, PL-2, PH-2, PH-3

Code #	Bolt Part Number	Bolt Length Inches	Bolt Thread & Type
0	0106340048	0.75	1/4-20 SHCS
1	0106340100	1.00	1/4-20 SHCS
2	0106340116	1.25	1/4-20 SHCS
3	0106340132	1.50	1/4-20 SHCS
4	0106340148	1.75	1/4-20 SHCS
5	0106340200	2.00	1/4-20 SHCS
6	0106340216	2.25	1/4-20 SHCS
7	0106340232	2.50	1/4-20 SHCS
8	0106340248	2.75	1/4-20 SHCS
9	0106280024	0.38	#8-32 SHCS
A	0106280032	0.50	#8-32 SHCS
B	0106280100	1.00	#8-32 SHCS
C	0106280132	1.50	#8-32 SHCS
D	0104530024	0.38	#8-32 PHS
E	0104530032	0.50	#8-32 PHS
F	0106340056	0.88	1/4-20 SHCS
G	0106340040	0.62	1/4-20 SHCS

Mounting Bolts for SHM

Code #	Bolt Part Number	Bolt Length mm	Bolt Thread & Type
H	1474210030	30	M6X1.0 SHCS
J	1474210040	40	M6X1.0 SHCS
K	1474210045	45	M6X1.0 SHCS
L	1474210025	25	M6X1.0 SHCS
M	1474210065	65	M6X1.0 SHCS
N	1487220210	10	M6X1.0 SHCS
P	1487640010	10	M6X1.0 SHCS (LOW HEAD)
Q	1474190035	35	M4X0.7 SHCS
R	1487220212	12	M4X0.7 FHSS
S	1487220216	16	M4X0.7 FHSS
T	1487220220	20	M4X0.7 FHSS
U	1474210035	35	M6X1.0 SHCS
V	1487220208	8	M4X0.7 FHSS
W	1474210020	20	M6X1.0 SHCS
X	1474210055	55	M6X1.0 SHCS
Y	1474210060	60	M6X1.0 SHCS
Z	0108800016	1/4" HI COLLAR LOCK WASHER, 4 REQ'D	

FHSS=Flat Head Socket Screw

PHS=Phillip Head Screw

PA-2 Series Counter Balance Cylinder

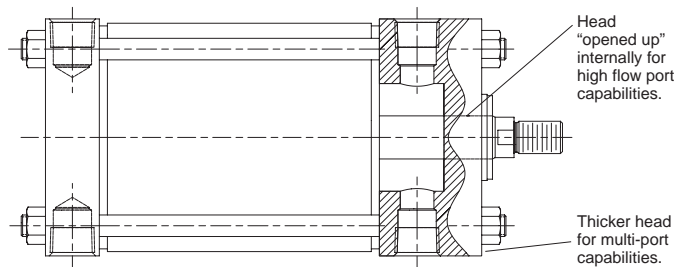

The innovative PA-2 Series Counter Balance Cylinder is designed with special dimensioned heads and caps opened up internally to allow for the high flow port option. The heads and caps are also thicker to accommodate multi-porting capabilities.

Standard Specifications

- Square head – tie rod design.
- Bore sizes – 1½" through 14" standard.
- Nominal pressure – to 250 PSI air.
- Strokes available in any practical length.
- Porting properly sized for optimum air flow.
- Heads and caps properly sized to accommodate porting.
- Case hardened, chrome plated piston rod is standard.

An efficient counter balance system consists of cylinders working in conjunction with receiver tanks to balance a vertical load, with minimized restrictions to air flow situations. Simplified examples of a cylinder and an air tank are shown below in Figures A and B.

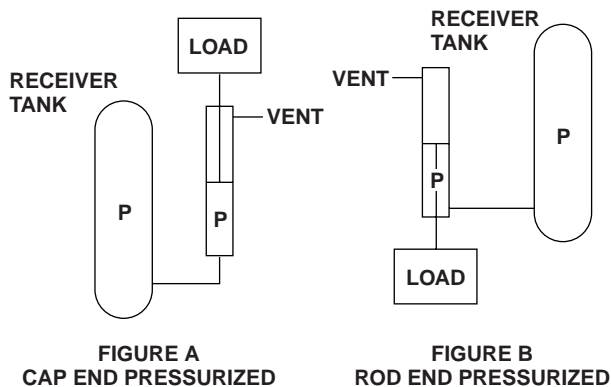

Pipe Schedule Chart

A _F for Proper Pipe			
Pipe	A _F (in. ²)	Pipe	A _F (in. ²)
½	.304	1½	2.036
¾	.533	2	3.356
1	.864	2½	4.788
1¼	1.496	3	7.392

In many vertical driven load applications, use of the Counter Balance Cylinder is very effective for load control. The machine designer must assure that the cylinder itself does not become an excessive restricting factor. Restricting factor occurs when rapidly moving air tries to pass through a cylinder port or other orifice.

Excessive restricting factor will usually show up as higher than anticipated motor current draw at the vertical drive. The higher amperage causes increased electricity costs. Also the additional mechanical load due to air flow restricting factor could cause premature failure of motor, drive or other machine components.

The PA-2 Series Special Counter Balance Cylinders are specifically designed for applications where it is desirable to reduce the restricting factor of air flow through a cylinder orifice. An excellent guideline to follow regarding restricting factor is to have standard condition air velocity through the cylinder port at or below 5,000 feet per minute.

By applying the following information, you can properly size ports for a flow rate within the 5,000 feet/minute guideline.

- Cylinder Bore (D)..... in.
- Cylinder Rod Size (d) in.
- Stroke Length (l)..... in.
- Stroke Time (t)..... Sec.
- Receiver Tank Pressure (P) P.S.I.

Using the above information in the following formulas, with the provided Pipe Schedule Chart, you can properly size the Counter Balance Cylinder ports at both pressurized and vented ends.

AE: Cylinder Piston Areas

AE for cylinders connected to receiver tank as shown in Fig. A, cap end pressurized

$$AE = \frac{\pi \times D^2}{4} = \text{___} \text{ in.}^2$$

AE for cylinders connected to receiver tank as shown in Fig. B, rod end pressurized.

$$AE = \frac{\pi \times (D^2 - d^2)}{4} = \text{___} \text{ in.}^2$$

CR: Compression Ratio. At vented end, CR = 1.

$$CR = \frac{P + 14.7}{14.7} = \text{___}$$

A_F: Minimum Orifice Area for 5,000 ft./min. velocity.

$$A_F^* = \frac{AE \times l \times CR}{1000t} = \text{___} \text{ in.}^2$$

*A_F can be achieved by the use of one or two ports. Once A_F is found, compare to pipe chart shown at left for required flow areas in in². Select proper pipe schedule based upon operating pressure.

- The counterbalance version of the heavy duty PA-2 cylinder is a special and cannot be ordered directly from a standard PA-2 catalog.
- When dealing with extreme air velocities, it is critical that the PA-2 cylinder load, stroke, and speed requirements are satisfied before attempting to use the provided formulas.
- Once the flow rate guideline of 5,000 feet/minute is satisfied, provide the proper port size to accommodate the pipe size shown on the chart to the left. Apply minimum orifice area formula A_F (in.²) to match proper port size.



NOTES

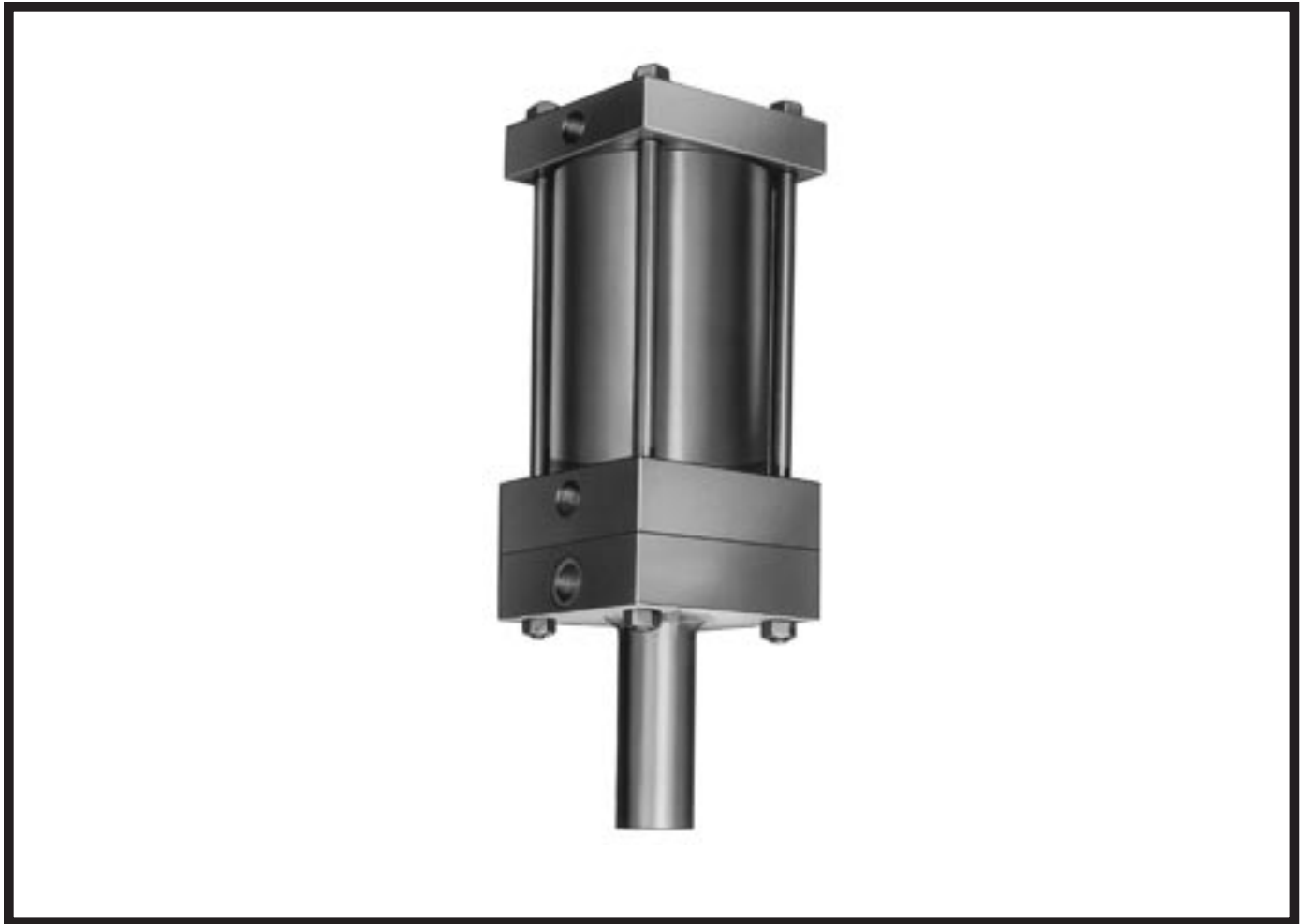

- **Maximum Input Pressures:**
 - Air – 250 psi (17 BAR)
 - Oil – 1000 psi (69 BAR)
- **Maximum Output Pressures:**
 - 5/8" to 3" RAM – 5000 psi (345 BAR);
 - 3 1/2" to 5" RAM – 3000 psi (206 BAR)
- **Maximum Operating Temperatures:**
 - 10°F to +165°F (-23°C) to (+74°C)

Schrader Bellows Intensifiers

Designed to Save Energy, Time, Space and Money in a Wide Variety of Applications.

A Schrader Bellows Intensifier is an efficient way of generating high pressure hydraulic fluid. Its operation is quite simple. Pressurized fluid – either air or oil – enters the intensifier and acts on a confined piston. This in turn drives a smaller diameter ram or piston to deliver a given volume of fluid. As a result, the output pressure is intensified and is considerably higher than the input pressure.

By using a Schrader Bellows Intensifier you can save in many ways. First, since it requires only low pressure input and less costly control valving, you eliminate the extra expense of high pressure pumps, valving and a large electrical power source. The simpler mountings and controls also save you valuable installation time.

In addition, since Schrader Bellows Intensifiers produce high hydraulic pressure, you can save space by using a smaller bore hydraulic cylinder in place of a larger bore air cylinder that is heavier and more costly.

Finally, because of the rugged dependability of Schrader Bellows Intensifiers and the simpler circuitry required, you eliminate the constant motion, heat generation and power consumption found in pump systems. This means that you use less energy with less downtime and maintenance.

These abilities and benefits of Schrader Bellows Intensifiers make them the ideal component in many applications. You can use them for such operations as marking, forming, molding, punching, riveting, shearing, straightening, laminating, embossing, welding and testing.

What's more, the Schrader Bellows Intensifier can be mounted on or off the equipment and can even be integrally combined with the work cylinder. This flexibility makes them particularly useful hydraulic pressure sources on portable equipment.



Schrader Bellows Intensifiers are available in various sizes and configurations. There are cylinder-to-ram units with capability for either single pressure or dual pressure service (left above), as well as several cylinder-to-cylinder models (above right).

Here are the features you'll find in every Schrader Bellows Intensifier:

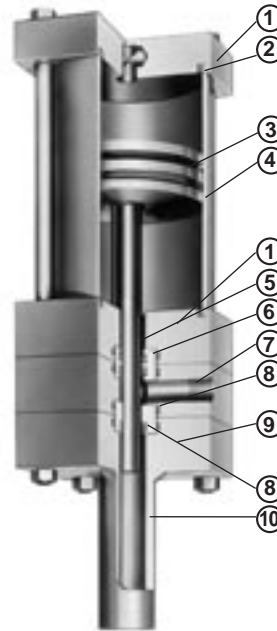

1. Compact, high-strength steel heads, cap and tie rods meet the most demanding applications.
2. Seal by pressure O-rings serve as cylinder body-to-head seals prevent leaks. The cylinder body is also piloted on the O.D. to insure metal-to-metal contact to support the seals.
3. The rugged one-piece iron piston is threaded and Loctited to the ram. Schrader Bellows Lipseal™ piston seals are used with air; piston rings with hydraulic fluid.
4. The driving cylinder body is steel tubing with chrome-plated bore for corrosion-resistance in bore sizes 3 1/4" through 14" sizes.
5. The smooth, wear-resistant surface of the chrome-plated and induction-hardened ram greatly lengthens seal life.
6. Static O-ring seals prevent leaks past the O.D. of the glands. Back-up washers prevent extrusion.
7. Intensifier operation is speeded up by the free flow of fluid in and out of the unobstructed ports. All high-pressure hydraulic ports are SAE straight thread o-ring type for leak-proof service.
8. Rod Lipseals are self-compensating and self-adjusting to provide leakproof ram seal for both high and low pressure operation.
9. For servicing the high pressure ram seals, the pressure chamber is independently secured with studs so it can be easily removed without disassembling the complete intensifier.
10. For optimum strength and safety, the pressure chamber wall is made of extra thick steel tubing that is piloted in a counterbore and pressure-welded to the head.

5. The smooth, wear-resistant surface of the chrome-plated and induction-hardened ram greatly lengthens seal life.
6. Static O-ring seals prevent leaks past the O.D. of the glands. Back-up washers prevent extrusion.
7. Intensifier operation is speeded up by the free flow of fluid in and out of the unobstructed ports. All high-pressure hydraulic ports are SAE straight thread o-ring type for leak-proof service.
8. Rod Lipseals are self-compensating and self-adjusting to provide leakproof ram seal for both high and low pressure operation.
9. For servicing the high pressure ram seals, the pressure chamber is independently secured with studs so it can be easily removed without disassembling the complete intensifier.
10. For optimum strength and safety, the pressure chamber wall is made of extra thick steel tubing that is piloted in a counterbore and pressure-welded to the head.

Dual Pressure Circuit

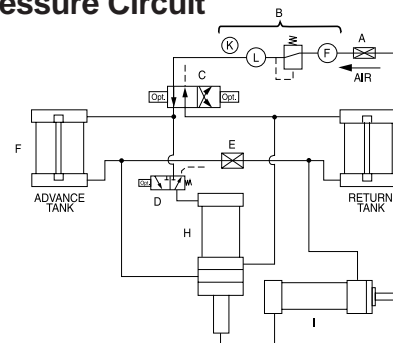

- | | |
|--|-----------------------------|
| A Cutoff Valve | F Advancing Tank (Air-Oil) |
| B Air Preparation Unit (Filter Regulator Lubricator-Gauge) | G Retracting Tank (Air-Oil) |
| C 4-Way Valve (Normally 2 Position) | H Intensifier |
| D 3-Way Valve | I Work Cylinder |
| E Cutoff Valve (For Balancing Tank Fluid Levels) | |

Dual Pressure Circuit (continued)

This basic circuit is for a dual pressure system supplying pressure to a double-acting work system. The circuit may be readily changed for other operating conditions such as single acting cylinder and single pressure delivery.

The input pressure is introduced to the system through shop air lines to the 4-way directional control valve C. When valve C is shifted to position as shown, air is directed into air-oil tank F and to valve D. Oil, acted upon by air pressure, is forced from tank through pressure chamber of retracted intensifier and into work cylinder. The cylinder advances in stroke, being driven by this incoming oil. At a predetermined point in the stroke length of the work cylinder, valve D is synchronized to shift and direct air pressure to the intensifier to drive it in its power stroke, isolating tank F and supplying high pressure to work cylinder for its high thrust stroke. The work cylinder and intensifier are retracted by

the shifting of valves C and D simultaneously to exhaust the intensifier and tank F. At the same time, air pressure is directed to tank G and to rod end side of intensifier piston. Oil from tank G retracts cylinder at low pressure.

The operators for valves C and D are optional – mechanical, manual, pilot or solenoid. The method of synchronizing valve D to stroke length position of work cylinder is also optional. This may be done by pilot control, limit switch, pressure switch, mechanically such as cams, or manually.

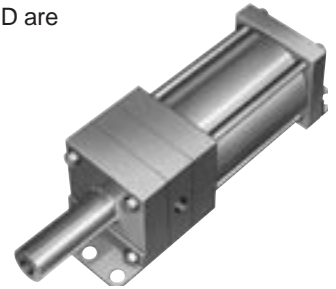

How to Select Schrader Bellows Intensifiers

Step 1: Determine the intensifier ratio for your application. This is the ratio of the available input fluid pressure and the output operating pressure required for the application. For cylinder-to-ram or cylinder-to-cylinder units, use the following formula:

$$\text{Intensifier ratio} = \frac{\text{Output pressure}}{\text{Input pressure}}$$

Step 2: Locate the intensifier ratio in column 5 of the appropriate chart on page 44. If the exact ratio is not shown, use the next larger ratio listed. When more than one choice is possible, usually the smallest driving cylinder bore size for a given intensifier ratio is the most economical answer.

Step 3: On same horizontal line as ratio determined in Step 2, select the driving cylinder bore size from column 1 and the ram diameter or driven cylinder bore size from column 3.

Note: For cylinder-to-ram applications, proceed with Steps 4 and 5. If a cylinder-to-cylinder unit is required, go to Step 6.

Step 4: Determine the type of cylinder-to-ram intensifier needed. Generally, a single pressure intensifier is used when the hydraulic work cylinder requires a high pressure for the entire stroke or in test vessel applications. A dual pressure intensifier is recommended if the high pressure is to be used only during the last portion of the work cylinder stroke.

Step 5: Calculate the intensifier stroke.

For single pressure intensifiers, use the formula:

$$\text{Intensifier stroke} = \frac{V + V_c}{A_r}$$

For dual pressure intensifier, use this formula:

$$\text{Intensifier stroke} = \frac{V_h + V_c + 2''^*}{A_r}$$

Where: V = work cylinder volume or test vessel fluid requirement in cubic inches.

V_h = oil volume in cubic inches required to move the work cylinder piston through its high pressure stroke.

V_c = compressibility allowance of 1% per 1000 psi of total volume in cubic inches of oil in the high pressure circuit, determined from:

V_c = total volume x .01 x high pressure/1000.

A_r = area of intensifier ram in square inches.

*This 2" is the intensifier stroke advance necessary to close the high pressure seal on dual pressure intensifiers only.

Note: If the calculated intensifier stroke results in a fraction, correct to the next larger **even** inch. The recommended maximum stroke is 20". If stroke calculation results in longer than 20" stroke, select a larger driving cylinder and ram having a similar intensifier ratio and recalculate stroke.

Step 6: For cylinder-to-cylinder intensifiers: Select the proper output cylinder. Since the output pressure is limited by the cylinder construction, the cylinder should be selected using the maximum pressure to be developed under nonshock conditions.

For Schrader Bellows PL-2 and PH-2 Series hydraulic cylinders, the maximum pressures under nonshock conditions are:

- PL-2 Series: 1 1/2" – 2500 psi; 2" – 2000 psi; 2 1/2" – 1800 psi;
 3 1/4" – 2000 psi; 4" – 1350 psi; 5" – 1500 psi;
 6" – 1100 psi; 8" – 900 psi

PH-2 Series: All bore sizes – 3000 psi.

General Guidelines

1. Intensifiers are generally faster operating when:
 - a. There is adequate input pressure.
 - b. The ports and piping are large enough. Consider the use of oversize ports and connecting lines, to minimize pressure drop.
 - c. The intensifier is pre-exhausted prior to the power stroke.
 - d. Size hydraulic lines so that fluid flow velocity does not exceed 7 feet per second.
2. Bypass the intensifier with a pre-fill low pressure line by direct connection through a check valve to the pressure vessel.
3. Regulate the driving pressure to the intensifier to achieve the required high pressure output.
4. Keep all piping lengths to a minimum by having the tanks, intensifier and pressure vessel as close together as possible.
5. A single pressure intensifier usually provides faster cylinder action because it does not need to change from low to high pressure but instead immediately supplies the high pressure.
6. Intensifiers are generally used in circuits where limited quantities of high pressure fluid is required.

(Series PS and PD) Cylinder to Ram Intensifiers

Driving Cylinder		Hydraulic Ram		Intensifier Ratio	Theoretical Intensified Hydraulic Pressure (PSI) Using An Input Pressure Of					
Bore	Area	Dia.	Area of Volume Displ Per in Stroke		50	80	100	200	500	1000
Col. 1	Col. 2	Col. 3	Col. 4	Col. 5	Col. 6	Col. 7	Col. 8	Col. 9	Col. 10	Col. 11
3 1/4	8.296	5/8	.307	27.02	1351	2161	2702			
		1	.785	10.57	529	846	1057	2114		
		1 3/8	1.485	5.59	280	447	559	1118	2795	
		1 3/4	2.405	3.45	173	276	345	690	1725	3450
		2	3.142	2.64	132	211	264	528	1320	2640
4	12.566	5/8	.307	40.93	2046	3274	4093			
		1	.785	16.00	800	1280	1600	3200		
		1 3/8	1.485	8.46	423	677	846	1692	4230	
		1 3/4	2.405	5.23	262	418	523	1046	2615	
		2	3.142	4.00	200	320	400	800	2000	4000
5	19.635	5/8	.307	63.95	3197	5116				
		1	.785	25.01	1250	2000	2501	5002		
		1 3/8	1.485	13.22	661	1058	1322	2644		
		1 3/4	2.405	8.16	408	653	816	1632	4080	
		2	3.142	6.25	313	500	625	1250	3125	
6	28.274	5/8	.307	91.88	4594	7288	9188			
		1	.785	36.01	1800	2880	3601	7202		
		1 3/8	1.485	19.05	953	1524	1905	3810		
		1 3/4	2.405	11.76	588	941	1176	2352		
		2	3.142	9.00	450	720	900	1800	4500	
8	50.265	5/8	.307	122.71	6135	9776	12271			
		1	.785	48.99	2449	3919	4899	9798		
		1 3/8	1.485	26.52	1326	2122	2652	5304		
		1 3/4	2.405	16.43	821	1286	1643	3286		
		2	3.142	12.36	618	987	1236	2472		
10	78.540	5/8	.307	153.54	7677	12062	15354			
		1	.785	64.03	3201	5122				
		1 3/8	1.485	33.85	1693	2708	3385			
		1 3/4	2.405	20.90	1045	1672	2090	4180		
		2	3.142	16.00	800	1280	1600	3200		
12	113.10	5/8	.307	184.37	9218	14349	18437			
		1	.785	80.00	4000	6400	8000	16000		
		1 3/8	1.485	42.41	2120	3392	4241	8482		
		1 3/4	2.405	27.02	1351	2161	2702	5404		
		2	3.142	20.00	1000	1600	2000	4000		
14	153.94	5/8	.307	232.31	11615	18464	23231			
		1	.785	96.01	4800	7680	9601	19202		
		1 3/8	1.485	51.16	2558	4032	5116	10232		
		1 3/4	2.405	32.66	1633	2613	3266	6532		
		2	3.142	25.00	1250	2000	2500	5000		

(Series PC) Cylinder to Cylinder Intensifiers

Driving Cylinder		Driving Cylinder		Intensifier Ratio	Theoretical Intensified Hydraulic Pressure (PSI) Using An Input Pressure Of					
Bore	Area	Bore	Area		50	80	100	200	500	1000
Col. 1	Col. 2	Col. 3	Col. 4	Col. 5	Col. 6	Col. 7	Col. 8	Col. 9	Col. 10	Col. 11
3 1/4	8.296	1 1/2	1.767	4.69	235	375	469	938	2345	
		2	3.142	2.64	132	211	264	528	1320	2640*
		3 1/4	8.296	2.37	119	190	237	474	1185	2370*
4	12.566	1 1/2	1.767	7.11	356	569	711	1422	3555*	
		2	3.142	4.00	200	320	400	800	2000	4000*
		2 1/2	4.909	2.56	128	205	256	512	1280	2560*
5	19.635	1 1/2	1.767	11.11	556	889	1111	2222		
		2	3.142	6.25	313	500	625	1250	3125*	
		2 1/2	4.909	4.00	200	320	400	800	2000*	4000*
6	28.274	1 1/2	1.767	16.00	800	1280	1600	3200*		
		2	3.142	9.00	450	720	900	1800	4500*	
		2 1/2	4.909	5.76	288	461	576	1152	2880*	
8	50.265	1 1/2	1.767	22.25	1112	1778	2225	4450		
		2	3.142	16.00	800	1280	1600	3200*		
		2 1/2	4.909	10.24	512	819	1024	2048		
10	78.540	1 1/2	1.767	30.06	1503	2309	3006	6012		
		2	3.142	18.00	900	1440	1800	3600*		
		2 1/2	4.909	12.00	600	960	1200	2400*		
12	113.10	1 1/2	1.767	40.00	2000	3200	4000	8000		
		2	3.142	24.00	1200	1920	2400	4800*		
		2 1/2	4.909	16.00	800	1280	1600	3200*		
14	153.94	1 1/2	1.767	53.33	2666	4167	5333	10666		
		2	3.142	32.00	1600	2560	3200	6400*		
		2 1/2	4.909	21.33	1066	1667	2133	4266*		

*Not recommended for PL-2 Series driven cylinder, use PH-2 Series.

Cylinder to Cylinder Intensifier – Series PC

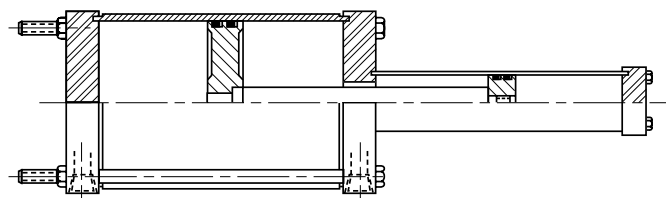

Schrader Bellows Cylinder to Cylinder Intensifiers (Series PC)

Series PC Intensifiers consist of two cylinders joined into an integral unit with one piston driving a second piston of smaller diameter. These intensifiers are not self-bleeding or self-filling, therefore, for the most effective operation, it is recommended that these tasks be done manually.

Special Note: It is recommended that Series PC cylinder-to-cylinder intensifiers be mounted vertically with the smaller cylinder up.

Bore	1 1/2	2	2 1/2	3 1/4	4	5	6	8	10	12	14
	PA-2 & PL-2 Series						PA-2 Series Only				
E	2	2 1/2	3	3 3/4	4 1/2	5 1/2	6 1/2	8 1/2	10 5/8	12 3/4	14 3/4
F	3/8	3/8	3/8	5/8	5/8	5/8	3/4	-	-	-	-
J	1	1	1	1 1/4	1 1/4	1 1/4	1 1/2	1 1/2	2	2	2 1/4
K	7/32	17/64	17/64	21/64	21/64	7/16	7/16	35/64	41/64	41/64	3/4
R	1.43	1.84	2.19	2.76	3.32	4.10	4.88	6.44	7.92	9.40	10.90
AA	2.02	2.6	3.1	3.9	4.7	5.8	6.9	9.1	11.2	13.3	15.4
BB	1	1 1/8	1 1/8	1 3/8	1 3/8	1 13/16	1 13/16	2 5/16	2 11/16	2 11/16	3 3/16
DD	1/4-28	5/16-24	5/16-24	3/8-24	3/8-24	1/2-20	1/2-20	5/8-18	3/4-16	3/4-16	7/8-14
EE	3/8	3/8	3/8	1/2	1/2	1/2	3/4	3/4	1	1	1 1/4
EE ₁	#6	#6	#6	#10	#10	#10	#12	#12	-	-	-
EB	-	-	-	-	-	-	-	11/16	13/16	13/16	15/16
FB	5/16	3/8	3/8	7/16	7/16	9/16	9/16	-	-	-	-
LD	2 5/8	2 5/8	2 3/4	3	3	3 1/4	3 1/2	3 5/8	4 5/8	5 1/8	5 7/8
LF	3 1/2	3 1/2	3 5/8	4 3/8	4 3/8	4 5/8	5 1/4	-	-	-	-
LJ	3 1/8	3 1/8	3 1/4	3 3/4	3 3/4	4	4 1/2	4 5/8	6 1/8	6 5/8	7 5/8
TE	-	-	-	-	-	-	-	7.57	9.40	11.10	12.87
T	2 3/4	3 3/8	3 7/8	4 11/16	5 7/16	6 5/8	7 5/8	-	-	-	-
TF	-	-	-	-	-	-	-	10.7	13.3	15.7	18.2
UF	3 3/8	4 1/8	4 5/8	5 1/2	6 1/4	7 5/8	8 5/8	-	-	-	-

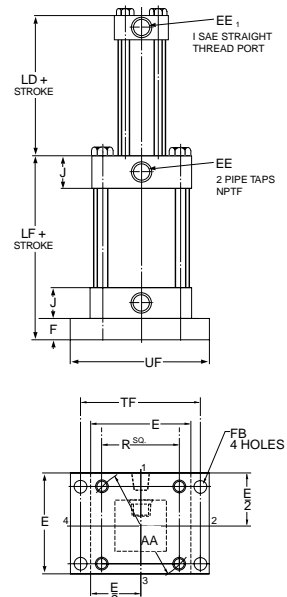

Mounting Style H Cap Rectangular Flange

This mounting available in driving cylinder bore sizes 3 1/4-inches through 6-inches.

MTG Styles are:
HA – Air Input
HL – Hyd. Input

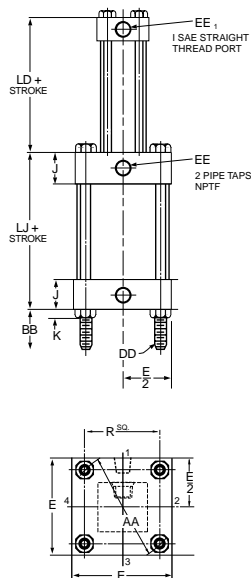

Mounting Style TC Cap Tie Rods Extended

This mounting available in driving cylinder bore sizes 3 1/4-inches through 14-inches.

MTG Styles are:
TCA Cap End – Air Input
TCL Cap End Hyd. Input

Bore	1 1/2	2	2 1/2	3 1/4	4	5	6	7	8
	PH-2 & PH-3 Series								
E	2 1/2	3	3 1/2	4 1/2	5	6 1/2	7 1/2	8 1/2	9 1/2
F	3/8	5/8	5/8	3/4	7/8	7/8	1	1	1
J	1 1/2	1 1/2	1 1/2	1 3/4	1 3/4	1 3/4	2	2 1/4	2 1/2
K	21/64	7/16	7/16	35/64	35/64	3/4	55/64	31/32	1 1/16
R	1.63	2.05	2.55	3.25	3.82	4.95	5.73	6.58	7.50
AA	2.3	2.9	3.6	4.6	5.4	7.0	8.1	9.3	10.6
BB	1 3/8	1 13/16	1 13/16	2 5/16	2 5/16	3 3/16	3 5/8	4 1/8	4 1/2
DD	3/8-24	1/2-20	1/2-20	5/8-18	5/8-18	7/8-14	1-14	1 1/8-12	1 1/4-12
EE	1/2	1/2	1/2	3/4	3/4	3/4	1	1 1/4	1 1/2
EE ₁	#10	#10	#10	#16	#16	#16	#16	#20	#24
FB	7/16	9/16	9/16	1 1/16	1 1/16	1 1/16	1 3/16	1 3/16	1 5/16
LD	3 3/8	3 3/8	3 1/2	4	4 1/4	4 3/4	5 5/8	6 1/4	7
LF	4 3/4	5	5 1/8	6	6 3/8	6 7/8	8 1/8	9	10
LJ	4 3/8	4 3/8	4 1/2	5 1/4	5 1/2	6	7 1/8	8	9
TE	3 7/16	4 1/8	4 5/8	5 7/8	6 3/8	8 3/16	9 7/16	10 5/8	11 13/16
UF	4 1/8	5 1/8	5 5/8	7 1/8	7 5/8	9 3/4	11 1/4	12 5/8	14

Maximum non-shock pressure rating for PL-2 and PH-2 Series can be found on page 56.

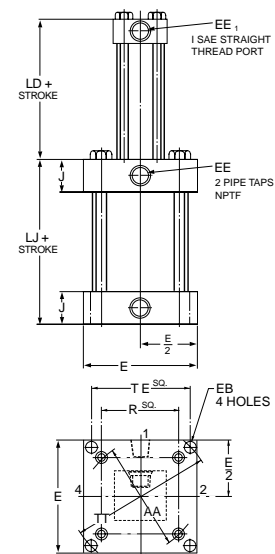

Mounting Style HB Cap Square Flange

This mounting available in driving cylinder bore sizes 8-inches through 14-inches.

MTG Styles are:
HBA – Air Input
HBL – Hyd. Input

Schrader Bellows Cylinder to Ram Dual Pressure Intensifiers (Series PD)

Series PD Intensifiers are similar to the Series PS units except a center head has been added to retain another gland and a third ram seal. When the ram is fully retracted, it withdraws from this third seal, allowing the low pressure hydraulic fluid to flow through the port in the center head. The fluid then goes past the ram and out the pressure chamber port to prefill and advance the work cylinder. Actually, this third seal and the ram act as a check valve. As the circuit sequences, the ram advances into the seal to close this "valve" and build up high pressure. With this arrangement and the proper mounting, Series PD intensifiers are self-bleeding and self-filling. And these intensifiers may be used in either single or dual pressure circuits.

Special Notes:

1. When equipped with integral air-oil tanks, Series PD intensifiers have a maximum input pressure of 150 psi.
2. It is recommended that Series PD dual pressure intensifiers be mounted vertically with the pressure chamber down.

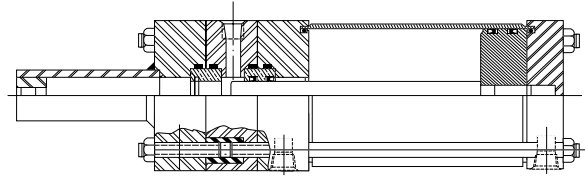

Dimensions Independent of Ram Size

Bore	3 1/4	4	5	6	8	10	12	14
	PA-2 & PL-2 Series					PA-2 Series		
E	3 3/4	4 1/2	5 1/2	6 1/2	8 1/2	10 5/8	12 3/4	14 3/4
G ₁	1 3/4	1 3/4	1 3/4	2	2	2 1/4	2 1/4	2 3/4
J	1 1/4	1 1/4	1 1/4	1 1/2	1 1/2	2	2	2 1/4
K	3/8	3/8	7/16	7/16	9/16	11/16	11/16	3/4
R	2.76	3.32	4.10	4.88	6.44	7.92	9.40	10.90
S	2 3/4	3 1/2	4 1/4	5 1/4	7 1/8	8 7/8	11	12 5/8
AA	3.9	4.7	5.8	6.9	9.1	11.2	13.3	15.4
AB	9/16	9/16	11/16	13/16	13/16	1 1/16	1 1/16	1 5/16
AH	1 15/16	2 1/4	2 3/4	3 1/4	4 1/4	5 5/16	6 3/8	7 3/8
AL	1 1/4	1 1/4	1 3/8	1 3/8	1 13/16	2 1/8	2 1/8	2 7/16
AO	1/2	1/2	5/8	5/8	11/16	7/8	7/8	1 1/16
AT	1/8	1/8	3/16	3/16	1/4	1/4	3/8	3/8
BB	1 3/8	1 3/8	1 13/16	1 13/16	2 5/16	2 11/16	2 11/16	3 3/16
DD	3/8-24	3/8-24	1/2-20	1/2-20	5/8-18	3/4-16	3/4-16	7/8-14
EE	1/2	1/2	1/2	3/4	3/4	1	1	1 1/4
EE ₁	#8	#8	#8	#8	#8	#12	#12	#16
FI	1 3/8	1 3/8	1 3/8	1 21/32	1 21/32	1 15/16	1 15/16	2 13/32
ST	5	5	5 1/4	5 3/4	6 5/8	8 1/4	8 1/4	9 3/8
ZI	413/64	413/64	4 3/4	5 1/4	5 55/64	7 21/64	7 21/64	8 7/16
ZK	6	6	6 1/2	7	8	10	10	11 1/2
ZN	8 3/8	8 3/8	8 7/8	9 1/2	10 1/8	12	12 1/2	14 1/2
ZO	6 61/64	6 61/64	7 5/16	7 15/16	8 11/64	9 41/64	10 9/64	11 3/4
ZS	9 29/64	9 29/64	10 5/16	10 15/16	11 11/64	13 41/64	14 9/64	16 1/4
ZZ	10 1/8	10 7/8	11 7/8	12 1/2	13 1/8	16	16 1/2	19

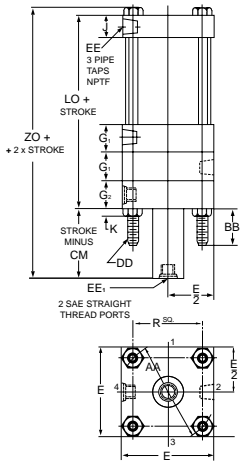

Mounting Style TB – Head Tie Rods Extended
(Styles TC – Cap Tie Rods Extended and TD – Both Ends Tie Rods Extended are also available. Dimensions "BB" remains the same in all cases.)

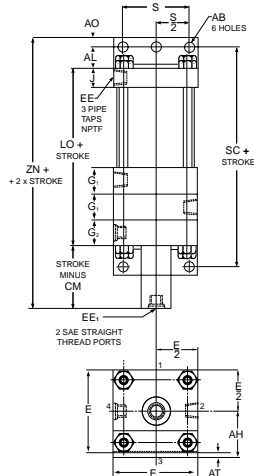

Mounting Style CB – End Angles

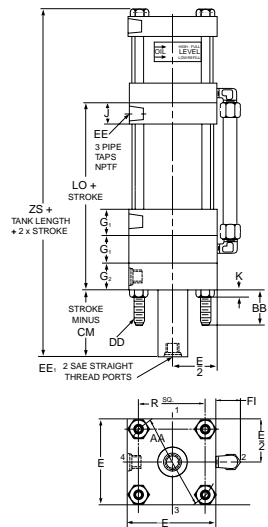

Mounting Style TB – Head Tie Rods Extended with Integral Air-Oil Tank

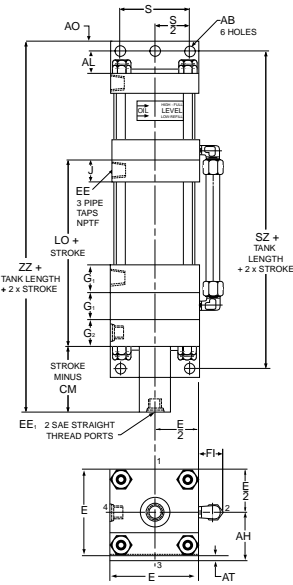

Mounting Style CB – End Angles with Integral Air-Oil Tanks

Dimensions Dependent on Ram Size

Bore	3 1/4	4	5	6	8	10	12	14
	PA-2 & PL-2 Series					PA-2 Series		
					1 3/8		2, 2 1/2	2 1/2, 3
					1 3/4, 2	1 3/4, 2	3, 3 1/2, 4	3 1/2, 4
G ₂	–	–	–	–	2	2	2 1/4	2 1/4
CM	–	–	–	–	1 1/2	1 5/8	1 7/8	2 1/8
LO	–	–	–	–	9 1/8	10 5/8	11 3/8	13 1/8
SC	–	–	–	–	10 3/4	12 7/8	13 3/8	15 3/4
SZ					13 3/4	16 7/8	17 3/8	20 1/4
					3 1/2, 5	3 1/2		
					5 1/2			
G ₂	1 3/4	1 3/4	1 3/4	2	2	2 1/4	2 1/4	2 3/4
CM	1 1/8	1 1/8	1 1/8	1 1/2	1 1/2	1 7/8	1 7/8	2 5/8
LO	7 3/4	7 3/4	8	9	9 1/8	10 7/8	11 3/8	13 5/8
SC	10 1/4	10 1/4	10 3/4	11 3/4	12 3/4	15 1/8	15 5/8	18 1/2
SZ	12 3/4	12 3/4	13 3/4	14 3/4	15 3/4	19 1/8	19 5/8	23

Schrader Bellows Cylinder to Ram Single Pressure Intensifiers (Series PS)

Series PS Intensifier delivers a single pressure through a double acting piston driving a ram. One seal on the ram gland works on the driving piston side; the other on the pressure chamber side. Since this intensifier is neither self-bleeding nor self-filling, for best performance it is recommended that these tasks be performed manually.

Special Note: It is recommended that Series PS single pressure intensifiers be mounted vertically with the pressure chamber up.

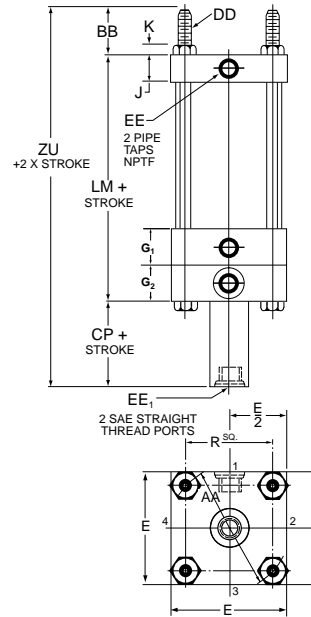
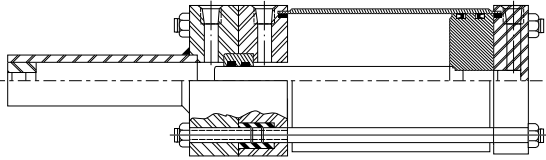

Dimensions Independent of Ram Size

Bore	3 1/4	4	5	6	8	10	12	14
	PA-2 & PL-2 Series				PA-2 Series			
E	3 3/4	4 1/2	5 1/2	6 1/2	8 1/2	10 5/8	12 3/4	14 3/4
G ₁	1 3/4	1 3/4	1 3/4	2	2	2 1/4	2 1/4	2 3/4
J	1 1/4	1 1/4	1 1/4	1 1/2	1 1/2	2	2	2 1/4
K	3/8	3/8	7/16	7/16	9/16	11/16	11/16	3/4
R	2.76	3.32	4.10	4.88	6.44	7.92	9.40	10.90
S	2 3/4	3 1/2	4 1/4	5 1/4	7 1/8	8 7/8	11	12 5/8
AA	3.9	4.7	5.8	6.9	9.1	11.2	13.3	15.4
AB	9/16	9/16	11/16	13/16	13/16	1 1/16	1 1/16	1 5/16
AH	1 15/16	2 1/4	2 3/4	3 1/4	4 1/4	5 5/16	6 3/8	7 3/8
AL	1 1/4	1 1/4	1 3/8	1 3/8	1 13/16	2 1/8	2 1/8	2 7/16
AO	1/2	1/2	5/8	5/8	11/16	7/8	7/8	1 1/16
AT	1/8	1/8	3/16	3/16	1/4	1/4	3/8	3/8
BB	1 3/8	1 3/8	1 13/16	1 13/16	2 5/16	2 11/16	2 11/16	3 3/16
DD	3/8-24	3/8-24	1/2-20	1/2-20	5/8-18	3/4-16	3/4-16	7/8-14
EE	1/2	1/2	1/2	3/4	3/4	1	1	1 1/4
EE ₁	#8	#8	#8	#8	#8	#12	#12	#16
ZU	8 3/8	8 3/8	9 1/6	9 9/16	10 3/16	11 13/16	12 5/16	14 1/16
ZX	8 3/4	8 3/4	9 1/4	9 3/4	10 3/8	12 1/8	12 5/8	14 3/8

Mounting Style TC – Cap Tie Rods Extended

(Style TB – Head Rods Extended, and TD – Both Ends Tie Rods Extended, are also available. Dimension “BB” remains the same in all cases.)

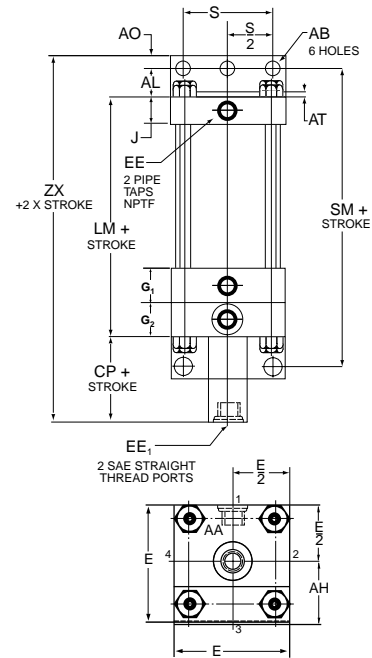

Dimensions Dependent on Ram Size

Bore	3 1/4	4	5	6	8	10	12	14
	PA-2 & PL-2 Series				PA-2 Series Only			
					Ram Sizes			
					1 3/8	2, 2 1/2	2 1/2, 3	
					1 3/4, 2	1 3/4, 2	3, 3 1/2, 4	3 1/2, 4
G ₂	–	–	–	–	2	2	2 1/4	2 1/4
CP	–	–	–	–	3/4	3/4	1/2	1/2
LM	–	–	–	–	7 1/8	8 3/8	9 1/8	10 3/8
SM	–	–	–	–	8 3/4	10 5/8	11 1/8	13
					Ram Sizes			
					2 1/2, 3	2 1/2, 3		
					3 1/2, 5	3 1/2,		
					5 1/2			
G ₂	1 3/4	1 3/4	1 3/4	2	2	2 1/4	2 1/4	2 3/4
CP	1	1	1	3/4	3/4	1/2	1/2	0
LM	6	6	6 1/4	7	7 1/8	8 5/8	9 1/8	10 7/8
SM	8 1/2	8 1/2	9	9 3/4	10 3/4	12 7/8	13 3/8	15 3/4

Mounting Style CB – End Angles



How to Order Schrader Bellows Intensifiers

How To Order

When ordering Schrader Bellows Intensifiers, please specify:

- a. Quantity
- b. Driving Cylinder bore size
- c. Mounting style – specify by using style letters given beneath dimension drawings.
- d. Driving cylinder operating fluid medium
- e. Intensifier series (PS, PD or PC)

f. Intensifier ram diameter (for cylinder-to-ram intensifiers) or Output cylinder bore (for cylinder-to-cylinder units)

g. Driving cylinder stroke

h. Input pressure, output pressure and volume

Note: Standard intensifiers are designed for use with petroleum base hydraulic oil. If other fluids will be used, please consult the factory.

Model Numbers

Each Schrader Bellows Intensifier has a model number. This, along with the driving cylinder bore size and stroke, is an accurate and coded description of the unit. The

chart here shows the elements of these model numbers. It is provided so that you can check our order acknowledgement against your order.

When Ordering Intensifiers By Model Number

Driving Cylinder Bore	Driving Cylinder Mounting Style	Driving Cylinder Operating Fluid		Intensifier Series	Driven Cylinder Series PC Only	Special Features	Intensifier Ram (or Driven Cylinder) Diameter		Driving Cylinder Stroke
3 1/4, 4, 5, 6, 8, 10, 12 or 14	CB, TB, TC, TD, H or HB	PA-2 (Air) or PL-2* (HYD.) Specify One Series Only	–	PD, PS, PC	PH-2 / PH-3 (3000 PSI Maximum) or PL-2 (900 to 2500 PSI Maximum Depending on Bore Size)	S Use Only if Intensifier Varies From Catalog	Specify From Dimension Tables	X	Specify For PD Style See Note Below

NOTE: PD style intensifiers require 2" additional stroke to seal the high pressure end. See page 43.

*PL-2 supplied with cast iron piston rings unless otherwise specified.

Specifications

Maximum Input Pressures:

Air – 250 psi (17 BAR); Oil – 1000 psi (69 BAR).

Maximum Operating Temperatures:

-10°F to +165°F (-23°C) to (+74°C).

Maximum Output Pressures:

5/8" to 3" RAM – 5000 psi (345 BAR);

3 1/2" to 5 1/2" RAM – 3000 psi (206 BAR).

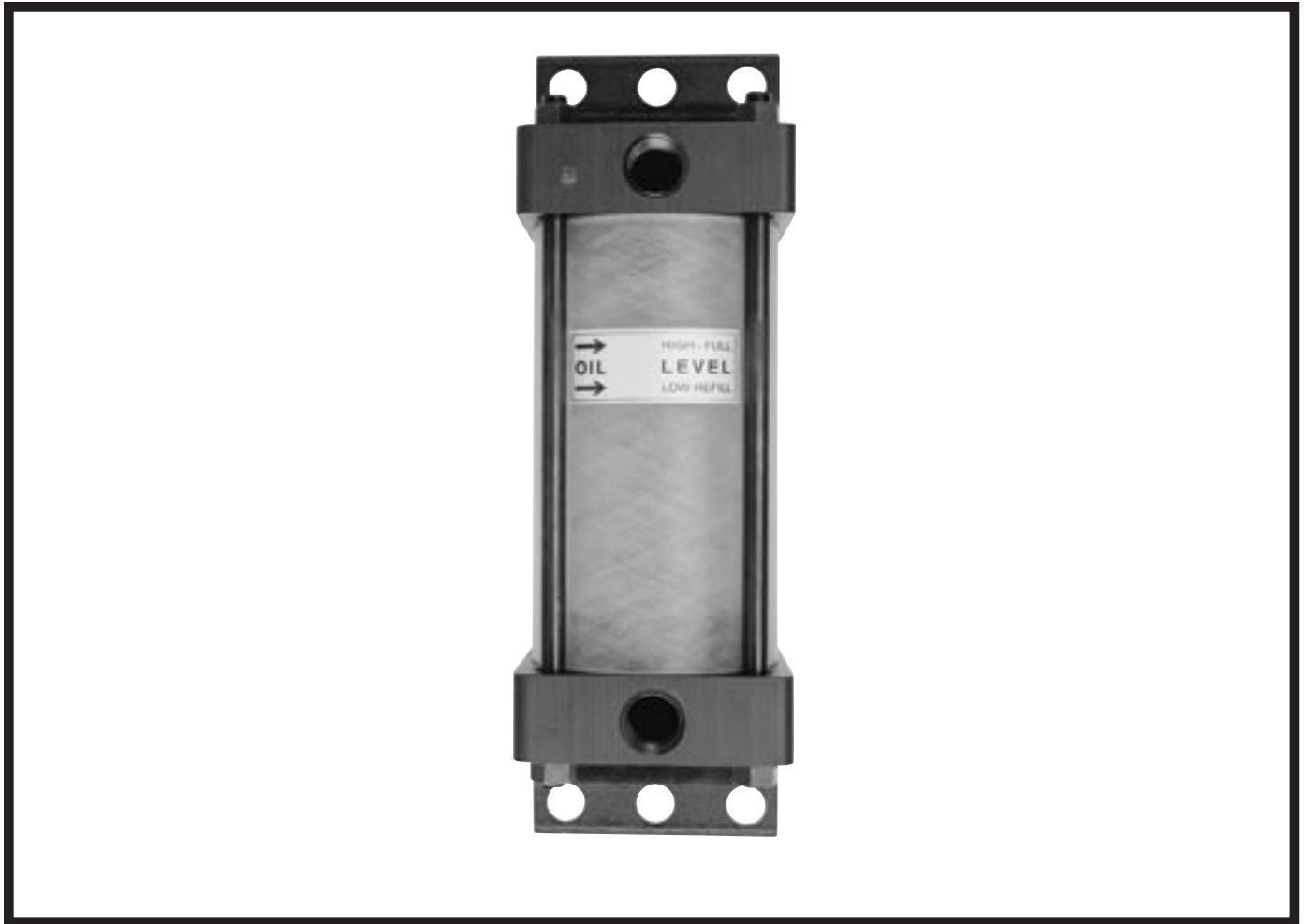

- 6 Standard Bore Sizes 2½" - 8" Bores
- Operating Pressure: Up to 250 psi
- Operating Temperature: 165°F Max.
- Lightweight Aluminum/Fiberglass Design
- Premium Quality and Economy
- Larger Bore Sizes Available

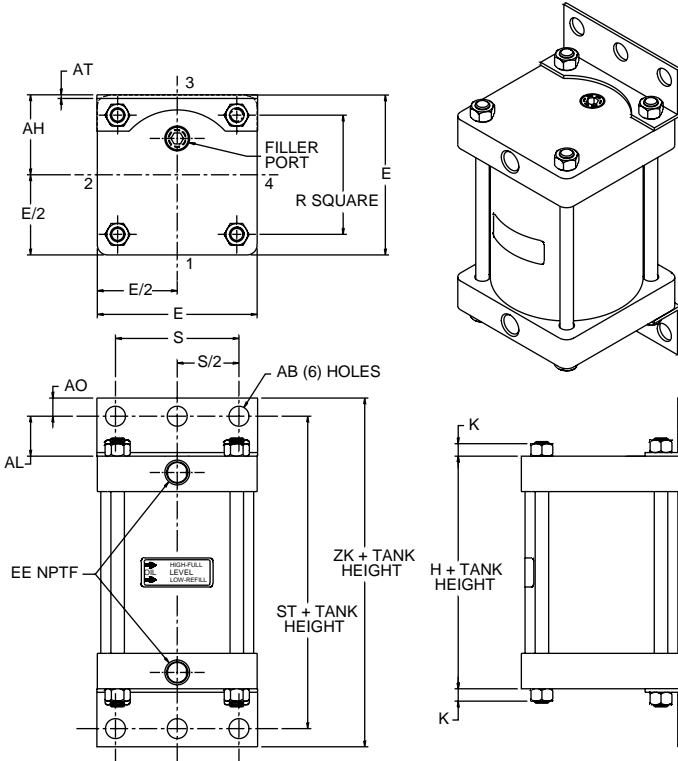

Mounting Style 01
Side end angles

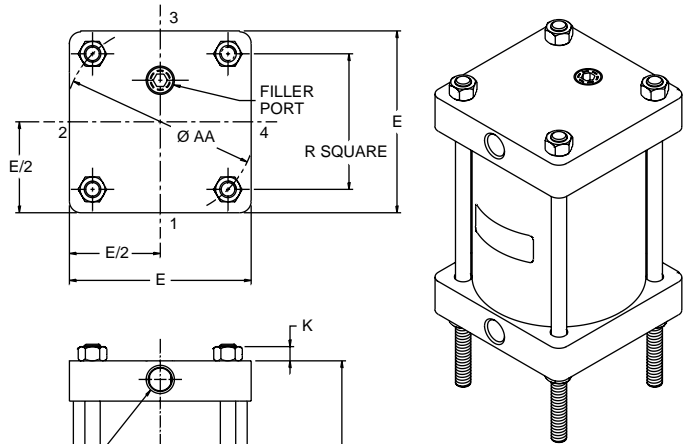

Mounting Style 57
Tie rods extended – oil end
Mounting Style 61
Tie rods extended – air end

Air-Oil Tanks Dimensions

Bore Size	E	H	K	R	S	AB	AH	AL	AO	AT	BB	DD	EE	ST	ZK
2 1/2	3	2	5/32	2.19	2 1/4	7/16	1 5/8	1	3/8	1/8	1 1/8	5/16-24	3/8	4	4 3/4
3 1/4	3 3/4	2 1/2	3/16	2.76	2 3/4	9/16	1 15/16	1 1/4	1/2	1/8	1 3/8	3/8-24	1/2	5	6
4	4 1/2	2 1/2	3/16	3.32	3 1/2	9/16	2 1/4	1 1/4	1/2	1/8	1 3/8	3/8-24	1/2	5	6
5	5 1/2	3	7/16	4.10	4 1/4	1 1/16	2 3/4	1 3/8	5/8	3/16	1 13/16	1/2-20	1/2	5 3/4	7
6	6 1/2	3	7/16	4.88	5 1/4	1 3/16	3 1/4	1 3/8	5/8	3/16	1 13/16	1/2-20	3/4	5 3/4	7
8	8 1/2	3	9/16	6.44	7 1/8	1 3/16	4 1/4	1 13/16	1 1/16	1/4	2 5/16	5/8-18	3/4	6 5/8	8

In a basic air-oil circuit the advance tank is connected to the cap end port of a hydraulic cylinder and the return tank to the head end port. Shop air is applied alternately to the two tanks through a 4-way air control valve. The oil in the advance tank is forced into the cap end of the cylinder to cause the piston rod to extend. At the same time, oil from the head end port is forced into the return tank, the air side of which is open to exhaust. To return cylinder to retract position, air pressure is applied to the oil in return tank.

To limit the fluid velocity, speed controls should be applied to the air side of the tank to restrict the exhaust.

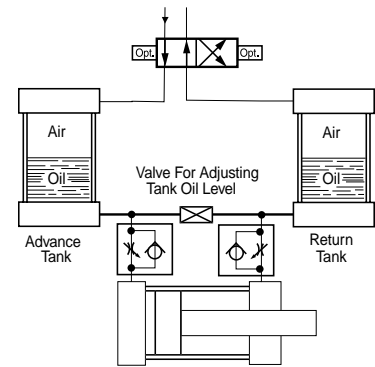

Table A Rated Capacities – Cubic Inches

USABLE TANK VOLUME (CUBIC INCHES)												
INTERNAL LENGTH OF TANK												
BORE	BORE CODE	5	6	7	8	9	10	12	14	16	18	20
2½	C	12	16.6	21.6	25.5	30	34	43	52	61	70	78
3¼	D	19	26	34	41	49	56	74	86	101	116	131
4	E	28	40	51	62	74	85	107	129	153	175	195
5	F	39	57	75	92	110	128	163	199	234	269	305
6	G	62	86	111	137	161	186	232	284	333	386	432
8	J	109	146	195	239	280	324	414	504	592	684	774

How to Select

Step 1: Determine the volume (cu. in.) of fluid required to fill the work cylinder at full stroke by taking the bore area times the stroke length.

Step 2: Select the proper tank bore height from the chart. Since there are usually several combinations with similar capacities, select the one having a rated capacity closest to but slightly greater than your volume requirements. Generally, the most economical choice is a higher tank with a smaller bore.

Air-Oil Tanks – For Smoother Hydraulic Flow

Schrader Bellows Air-Oil tanks provide a means to convert shop air pressure into hydraulic pressure. Compressed air is applied directly to the oil in the air-oil tank to convert it into hydraulic pressure. The hydraulic pressure is at a 1-to-1 ratio, i.e. 80 psi air produces 80 psi hydraulic pressure.

All Schrader Bellows Air-Oil tanks have a fiberglass tube which shows the proper oil level. They also contain two fluid flow baffles. The top baffle disperses the incoming air over the surface of the oil in such a way to avoid agitation and aeration. The bottom baffle insures a smooth flow pattern that minimizes oil turbulence and eliminates swirling, funneling or splashing which in turn could cause oil aeration or the oil to be blown from the tank into the exhaust air.

Air-Oil tanks are used to smooth out the cylinder piston rod travel and to prevent chatter. They are mainly used in slow speed circuits. Fluid velocity in or out of the tank through standard ports should be less than 6 feet per second to prevent aeration of the oil. Since each tank is designed for a specific port size, increasing the port size in a tank to lower the fluid velocity is not recommended. A tank with a larger port size should be selected.

How To Order

When ordering Schrader Bellows Air-Oil Tanks, please specify:

- a. Type **F02**
- b. Bore Code (see above)
- c. Rod Code **NN** (none)
- d. Mount **01** (side end angles), **57** (tie rod extended - oil end), **61** (tie rods extended - air end)
- e. Rod Style **N** (none)
- f. Seals **1** (Buna N)
- g. Tank Length

Example: F02 E NN 01 N 1 x 6.00

Notes: Standard air-oil tanks are designed for use with petroleum base hydraulic oil. If other fluids will be used, please consult the factory. For larger than 8" Bore Sizes consult factory.



NOTES

Cylinder Parts Identification and Seal Kit Data

Series CHE/CHD Cylinders	
Parts Identification, Seal Kits	Pages 30-31
PA-2, PL-2, PH-2 and 7" & 8" Bore PH-3 Series Cylinders	
Mountings, Parts Identification, Cushion Kits – Standard and Fluorocarbon.....	Pages 32-34
PA-2, PL- 2 Series Cylinders	
Standard Seal Kit, Fluorocarbon Seal Kits	Pages 35-36
PN Series	
Parts Identification, Seal Kits	Page 37
PH-2 Series Hydraulic Cylinders	
Parts Identification, Seal Kits – Standard and Fluorocarbon.....	Pages 38-39
PH-3 Series and PH-3 Series Large Bore Hydraulic Cylinders	
Parts Identification, Seal Kits, Maintenance, Optional Piston Seal Kits	Page 40-43
PL-2 Series	
Gland Seal Kits, Parts Identification	Page 44
SHM Series Cylinders	
Replacement Parts and Service, Parts Identification	Pages 45-46
SH/SHG Series	
Parts Identification, Thrust Key, Seal Kits	Pages 47-48

Parts Identification Drawing – Standard Piston

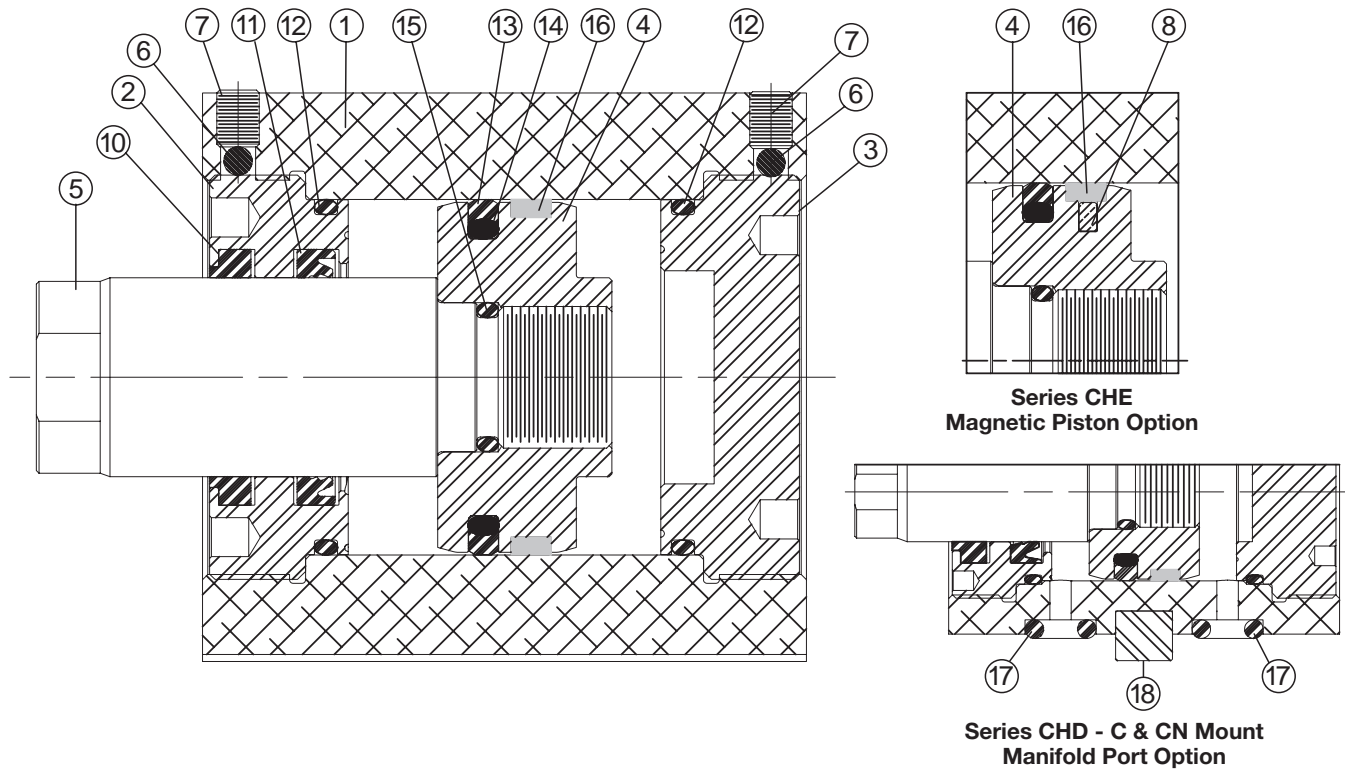

Item No.	Description	Material	Item No.	Description	Material	
					Standard	Fluorocarbon
1	Cylinder Body - CHE	Aluminum Alloy (Hard Anodized)	10	Rod Wiper	PUR	Fluorocarbon
	Cylinder Body - CHD	Steel	11	Rod Seal	PUR	Fluorocarbon
2	Gland	Nodular Iron or Bronze	12	End Seal	PUR	Fluorocarbon
3	Cap	Nodular Iron or Bronze	13	Piston Seal	PUR	Filled PTFE
4	Piston – Standard	Nodular Iron	14	PS Energizer	NBR	Fluorocarbon
	Piston – with Magnet	Aluminum Alloy				
5	Piston Rod	Carbon Steel (Hard Chrome Plated)	15	Piston-to-Rod o-ring	PUR	Fluorocarbon
6	Ball	Nylon	16	Piston Wear Band	Glass-reinforced nylon	Glass-reinforced nylon
7	Set Screw	Alloy Steel				
8	Magnet	Sintered NdFeB ¹	17	Manifold Port Seal	PUR	Fluorocarbon
			18	C & CN Mount Key	Steel	

¹Neodymium Iron Boron

Seal Kits

See Standard Specifications Page for fluid and temperature compatibility. Cylinder gland and cap are threaded into the cylinder body. To service rod seal, rod wiper, piston seal, or end seals the gland or cap must be removed. Spanner holes in the gland and cap

are available for the purpose of removing and installing these components. Be sure to torque the gland or cap to the specifications below and replace the nylon ball and set screw to further lock them in place.

Rod Gland and Rod Seal Kits

Rod Ø	Rod Gland (w/o pilot ¹) Kits		Rod Seal Kits	
	Class 1	Class 5	Class 1	Class 5
	Consists of 1 ea. of items #2, 6, 10, 11, & 12		Consists of 1 ea. of items #6, 10, 11, & 12	
12	A63430A12	A63430B12	A63430C12	A63430D12
14	A63430A14	A63430B14	A63430C14	A63430D14
18	A63430A18	A63430B18	A63430C18	A63430D18
22	A63430A22	A63430B22	A63430C22	A63430D22
28	A63430A28	A63430B28	A63430C28	A63430D28
36	A63430A36	A63430B36	A63430C36	A63430D36
45	A63430A45	A63430B45	A63430C45	A63430D45
56	A63430A56	A63430B56	A63430C56	A63430D56

¹ Pilot gland is required for AN, CA, CN, J, MN and TN mounting styles. For Gland Kit with pilot change the '0' to a 'P' before the 'A' or 'B'. For example: A6343PA12.

Complete Seal Kits



Bore Ø	Class 1	Class 5	Gland & Cap Torque Specifications			
	Consists of 1 ea. of items #10, 11, 13, 14, 16 & 2 ea. of items #6 & 12		Series CHE		Series CHD	
	20	A63440A20	A63440B20	21 - 22 N-m	190 - 199 lb-in	34 - 35 N-m
25	A63440A25	A63440B25	41 - 43 N-m	30 - 31 lb-ft	61 - 64 N-m	45 - 47 lb-ft
32	A63440A32	A63440B32	81 - 85 N-m	60 - 63 lb-ft	129 - 135 N-m	95 - 99 lb-ft
40	A63440A40	A63440B40	156 - 163 N-m	115 - 120 lb-ft	230 - 241 N-m	170 - 178 lb-ft
50	A63440A50	A63440B50	258 - 270 N-m	190 - 199 lb-ft	434 - 455 N-m	320 - 336 lb-ft
63	A63440A63	A63440B63	434 - 455 N-m	320 - 336 lb-ft	847 - 889 N-m	625 - 656 lb-ft
80	A63440A80	A63440B80	847 - 889 N-m	625 - 656 lb-ft	1695 - 1779 N-m	1250 - 1312 lb-ft
100	A63440A00	A63440B00	1695 - 1779 N-m	1250 - 1312 lb-ft	-	-

Spanner Hole Dimensions

Gland & Cap Spanners

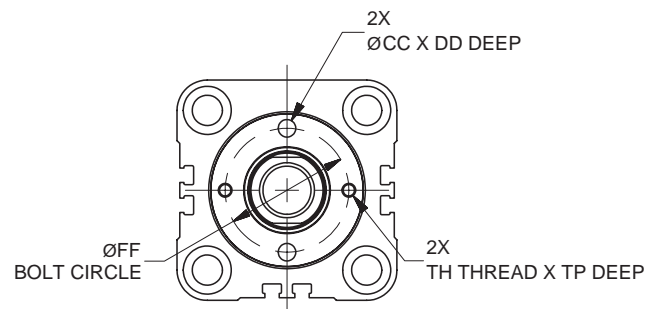
Bore Ø	CC	DD	FF Ø	TH	TP
20	2.75	2.75	22	-	-
25	3.25	3.25	25	-	-
32	4.25	4.25	30	M3x0.5 - 6H	6
40	5.25	5.25	35	M4x0.7 - 6H	7
50	6.38	6.25	45	M5x0.8 - 6H	7
63	8.38	8.25	55	M6x1 - 6H	8
80	10.50	10.50	70	M8x1.25 - 6H	9
100	10.50	10.50	85	M8x1.25 - 6H	9

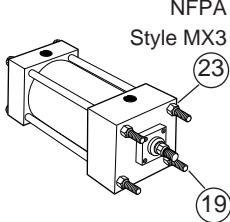
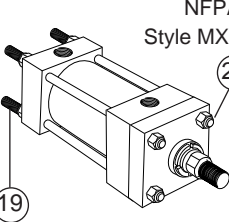
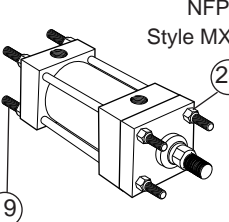
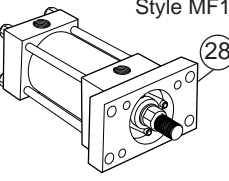
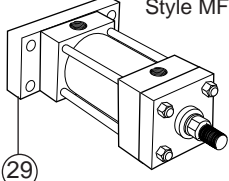
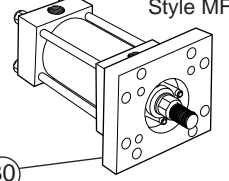
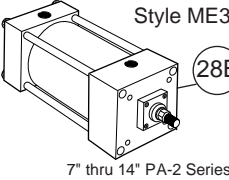
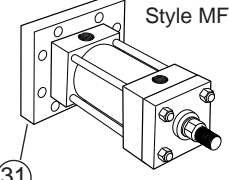
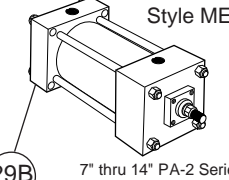
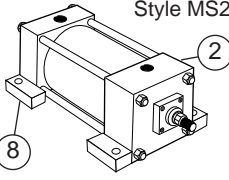
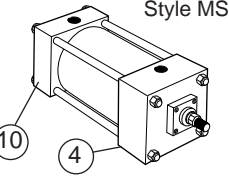
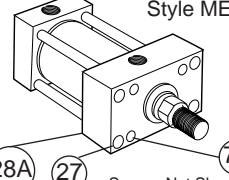
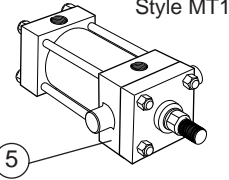
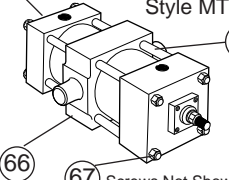
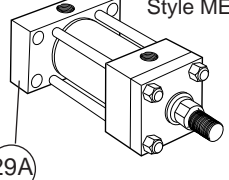

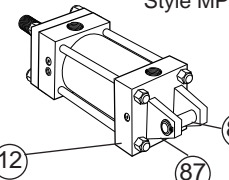
 <p>NFA Style MX3</p>	 <p>NFA Style MX2</p>	 <p>NFA Style MX1</p>	<h3 style="text-align: center;">Replacement Mountings and Hardware</h3> <p>Note: For items not shown see pages 24 and 25.</p> <table border="1" style="width: 100%; border-collapse: collapse;"> <thead> <tr> <th style="width: 15%;">Symbol</th> <th>Description</th> </tr> </thead> <tbody> <tr><td>2</td><td>Head, side lug mounting</td></tr> <tr><td>4</td><td>Head, side tap mounting</td></tr> <tr><td>5</td><td>Head, trunnion mounting</td></tr> <tr><td>8</td><td>Cap, side lug mounting</td></tr> <tr><td>10</td><td>Cap, side tap mounting</td></tr> <tr><td>11</td><td>Cap, trunnion mounting</td></tr> <tr><td>12</td><td>Cap, fixed clevis mounting</td></tr> <tr><td>19</td><td>Tie rod</td></tr> <tr><td>20</td><td>Tie rod, head end mounting</td></tr> <tr><td>21</td><td>Tie rod, cap end mounting</td></tr> <tr><td>23</td><td>Tie rod nut</td></tr> <tr><td>27</td><td>Retainer</td></tr> <tr><td>28</td><td>Flange, rectangular mounting</td></tr> <tr><td>28A</td><td>Head, rectangular mounting</td></tr> <tr><td>28B</td><td>Head, square mounting</td></tr> <tr><td>29</td><td>Flange, rectangular mounting</td></tr> <tr><td>29A</td><td>Cap, rectangular mounting</td></tr> <tr><td>29B</td><td>Cap, square mounting</td></tr> <tr><td>30</td><td>Flange, square mounting</td></tr> <tr><td>31</td><td>Flange, square mounting</td></tr> <tr><td>66</td><td>Intermediate trunnion</td></tr> <tr><td>67</td><td>Screws, intermediate trunnion mtg.</td></tr> <tr><td>79</td><td>Socket head cap screws</td></tr> <tr><td>86</td><td>Clevis pin mounting</td></tr> <tr><td>87</td><td>Retaining ring mounting</td></tr> </tbody> </table>	Symbol	Description	2	Head, side lug mounting	4	Head, side tap mounting	5	Head, trunnion mounting	8	Cap, side lug mounting	10	Cap, side tap mounting	11	Cap, trunnion mounting	12	Cap, fixed clevis mounting	19	Tie rod	20	Tie rod, head end mounting	21	Tie rod, cap end mounting	23	Tie rod nut	27	Retainer	28	Flange, rectangular mounting	28A	Head, rectangular mounting	28B	Head, square mounting	29	Flange, rectangular mounting	29A	Cap, rectangular mounting	29B	Cap, square mounting	30	Flange, square mounting	31	Flange, square mounting	66	Intermediate trunnion	67	Screws, intermediate trunnion mtg.	79	Socket head cap screws	86	Clevis pin mounting	87	Retaining ring mounting
Symbol	Description																																																						
2	Head, side lug mounting																																																						
4	Head, side tap mounting																																																						
5	Head, trunnion mounting																																																						
8	Cap, side lug mounting																																																						
10	Cap, side tap mounting																																																						
11	Cap, trunnion mounting																																																						
12	Cap, fixed clevis mounting																																																						
19	Tie rod																																																						
20	Tie rod, head end mounting																																																						
21	Tie rod, cap end mounting																																																						
23	Tie rod nut																																																						
27	Retainer																																																						
28	Flange, rectangular mounting																																																						
28A	Head, rectangular mounting																																																						
28B	Head, square mounting																																																						
29	Flange, rectangular mounting																																																						
29A	Cap, rectangular mounting																																																						
29B	Cap, square mounting																																																						
30	Flange, square mounting																																																						
31	Flange, square mounting																																																						
66	Intermediate trunnion																																																						
67	Screws, intermediate trunnion mtg.																																																						
79	Socket head cap screws																																																						
86	Clevis pin mounting																																																						
87	Retaining ring mounting																																																						
 <p>NFA Style MF1</p>	 <p>NFA Style MF2</p>	 <p>NFA Style MF5</p>																																																					
 <p>NFA Style ME3</p> <p>7" thru 14" PA-2 Series 8" Bore PL-2 Series</p>	 <p>NFA Style MF6</p>	 <p>NFA Style ME4</p> <p>7" thru 14" PA-2 Series 8" Bore PL-2 Series</p>																																																					
 <p>NFA Style MS2</p>	 <p>NFA Style MS4</p>	 <p>NFA Style ME5</p> <p>Screws Not Shown</p>																																																					
 <p>NFA Style MT1</p>	 <p>NFA Style MT4</p> <p>Screws Not Shown</p>	 <p>NFA Style ME6</p>																																																					
 <p>NFA Style MP1</p>	 <p>NFA Style MT2</p>	<p>How to Order Give cylinder model number, bore, stroke, serial number and symbol number shown above to insure proper replacement. Note: All mounting styles may not be available.</p>																																																					

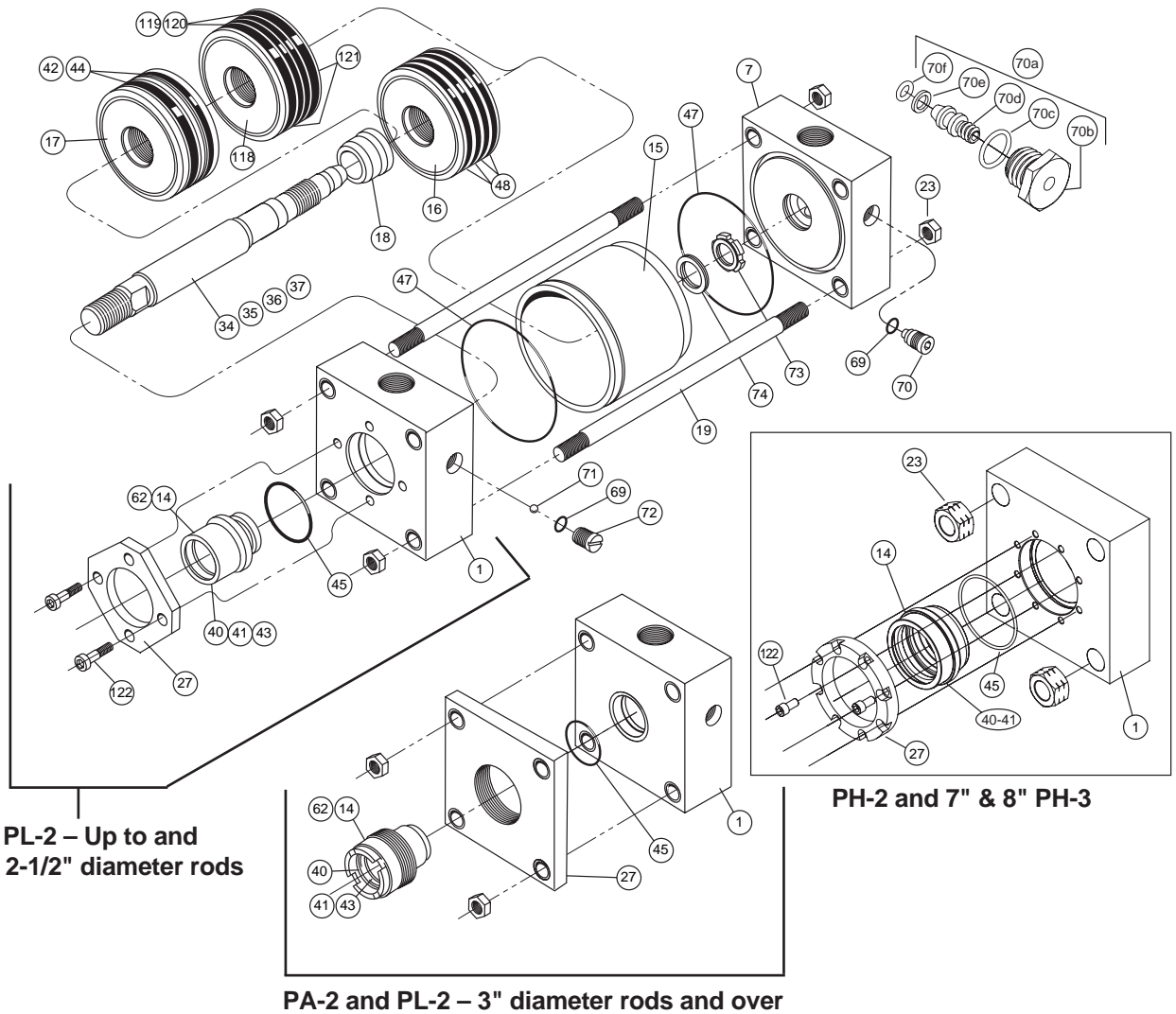

PA-2 and PL-2 – Up to and including 2-1/2" diameter rods

PA-2 and PL-2 – 3" diameter rods and over

PH-2 and 7" & 8" PH-3

Double End Rod and Piston Assembly

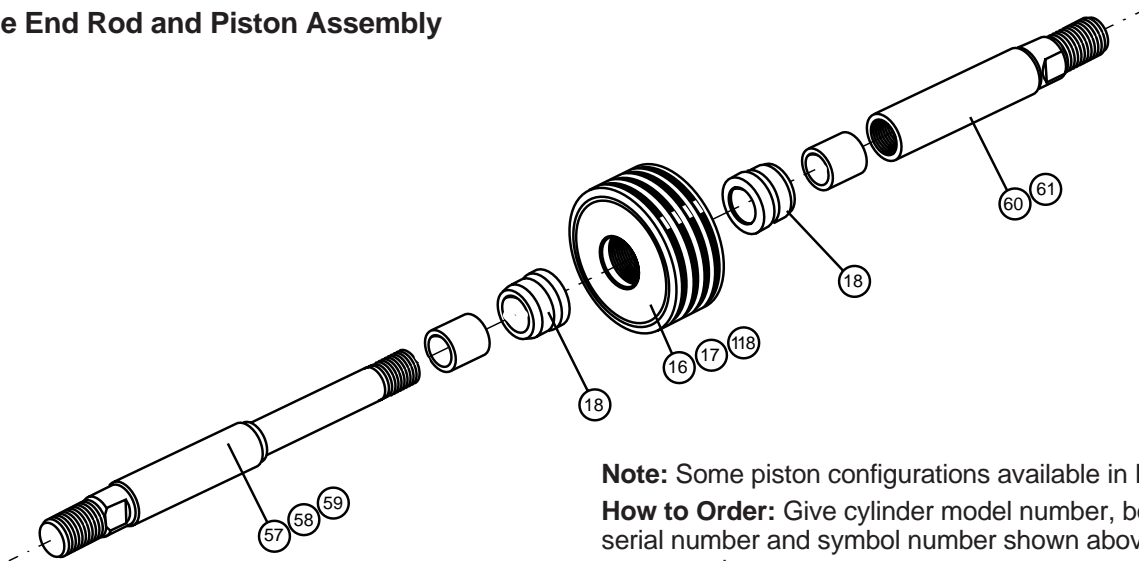

Note: Some piston configurations available in PH-2 only.
How to Order: Give cylinder model number, bore, stroke, serial number and symbol number shown above to insure proper replacement.



Note: For specific mounting styles see page 32.

Parts		Assemblies (Includes Symbol Numbers Shown)				
Symbol	Description	Symbol	Description	Ring Type Piston	Lipseal Type Piston	Hi-Load Type Piston
1	Head, ported, non-cushioned	C1SA	Head, ported, cushioned		1, 69, 70, 71 & 72	
7	Cap, ported, non-cushioned	C7SA	Cap, ported, cushioned		7, 69, 70, 73 & 74	
14	Gland	62	Gland cartridge kit		14, 40, 41, 43 & 45	
15	Cylinder body	—	—		—	
16	Piston body, ring type					
17	Piston body, lipseal type					
18	Cushion sleeve, cushioned cylinder only					
19	Tie rod					
23	Tie rod nut					
27	Retainer					
34	Piston rod, single rod type, non-cushioned	34SA	Piston & rod assembly, single rod type — non-cushioned	16, 34 & 48	17, 34, 42 & 44*	34, 118, 119, 120 & 121*
35	Piston rod, single rod type, cushioned head end	35SA	Piston & rod assembly, single rod type — cush. head end	16, 18, 35 & 48	17, 18, 35, 42 & 44*	35, 118, 119, 120 & 121
36	Piston rod, single rod type, cushioned cap end	36SA	Piston & rod assembly, single rod type — cush. cap end	16, 36 & 48	17, 36, 42 & 44*	37, 118, 119, 120 & 121
37	Piston rod, single rod type, cushioned both ends	37SA	Piston & rod assembly, single rod type — cush. both ends	16, 18, 37 & 48	17, 18, 37, 42 & 44	37, 118, 119, 120 & 121
40	Wiperseal, gland	—	Seal Kits		—	
41	Lipseal, gland					
42	Lipseal, piston					
43	Back-up washer, gland					
44	Back-up washer, piston					
45	O-ring, gland to head seal					
47	O-ring, cylinder body and seal					
48	Piston ring					
57	Piston rod, double rod type, non-cushioned					
58	Piston rod, double rod type, cushioned one end	58SA	Piston & rod assembly, double rod type — cushioned one end	16, 18, 48, 58 & 60	17, 18, 42, 44*, 58 & 60	18, 58, 60, 118, 119, 120 & 121
59	Piston rod, double rod type, cushioned both ends	59SA	Piston & rod assembly, double rod type — cushioned both ends	16, 18, 48, 58 & 61	17, 18, 42, 44*, 58 & 61	18, 58, 61, 118, 119, 120 & 121
60	Piston rod extension, double rod type, non-cushioned	—	—		—	
61	Piston rod extension, double rod type, cushioned					
69	O-ring, cushion adjustment & check valve screw	—	Cushion Kits See table below.		—	
70	Needle valve, cushion adjustment					
70a**	Needle valve, cushion adjustment - cartridge type					
70b	Cartridge screw					
70c	O-ring, cartridge screw					
70d	Needle screw					
70e	Back-up washer - needle screw					
70f	O-ring - needle screw					
71	Ball, check valve					
72	Plug screw, check valve					
73	Cushion bushing, cap end floating check valve					
74	Retaining ring, floating cushion bushing					
75	Seal, cushion sleeve					
118	Piston, hi-load type					
119	Outer ring	—	Seal Kits		—	
120	Inner ring					
121	Wear ring					
122	Socket cap screws	—	—		—	

**In some cases the adjusting screw is installed in a cartridge. *Piston back-up washer (Symbol 44) not supplied on PA-2 Series air cylinders.

Cushion Hardware Kits

Bore Size	Rod Dia.	PA-2 Series				PL-2 Series			
		For Head Assemblies <small>(Kits Include symbols 69, 70, 71, & 72)</small>		For Cap Assemblies <small>(Kits Include symbols 69, 70, 73, & 74)</small>		For Head Assemblies <small>(Kits Include symbols 69, 70, 71, & 72)</small>		For Cap Assemblies <small>(Kits Include symbols 69, 70, 73, & 74)</small>	
		Standard	Fluorocarbon	Standard	Fluorocarbon	Standard	Fluorocarbon	Standard	Fluorocarbon
1	All	None	None	None	None	A63221102	A63211005	A63221102	A63211005
1 1/2	5/8	A63211503	A63211005	A63211504	A63221502	A63221503	A63221503	A6321504	A63221502
	1	A63211002	A63211005			A63211002	A63211005		
2	5/8, 1	A63211503	A63221503	A63211504	A63221502	A63221503	A63221503	A6321504	A63221502
	1 3/8	A63211002	A63211005			A63211002	A63221503		
2 1/2	5/8 - 1 3/8	A63211503	A63221503	A63211504	A63221502	A63221503	A63221503	A6321504	A63221502
	1 3/4	A63211002	A63211005			A63211002	A63211005		
3 1/4	All	A63213203	A63223203	A63213204	A63223202	A63213203	A63223203	A63213202	A63223202
4	All	A63213203	A63223203	A63213204	A63223202	A63213203	A63223203	A63213202	A63223202
5	All	A63213203	A63223203	A63213204	A63223202	A63213203	A63223203	A63213202	A63223202
6	All	A63216003	A63226003	A63216004	A63226004	A63216003	A63226003	A63216004	A63226002
7	All	A63216003	A63226003	A63216004	A63226004	—	—	—	—
8	All	A63216003	A63226003	A63216004	A63229004	A63216003	A63226003	A63216004	A63226002
10	All	A63216003	A63226003	A63219004	A63229004	—	—	—	—
12	All	A63216003	A63226003	A63219204	A63229204	—	—	—	—
14	All	A63216003	A63226003	A63219404	A63229404	—	—	—	—

Symbol	Description
14	Gland cartridge
40	Gland wiperseal
41	Gland lipseal
42	Piston lipseal
43*	Gland back-up washer
44	Piston back-up washer
45	Gland to head o-ring
47	End seal o-ring
48	Piston ring
62	Gland cartridge kit

*Not used in PL-2 cylinders.

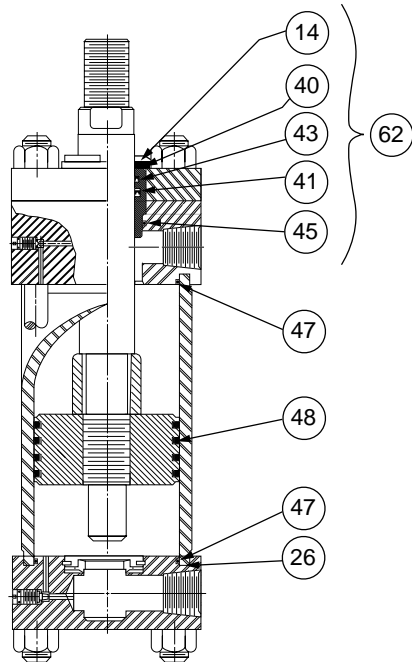

Seal Kits for Class 1 & 2 Service

Material: Buna-N (Nitrile) except item 41, in PL-2 series which is polyurethane.

For operating temperature and fluid compatibility, see Section C, pages 54 & 55.

Gland and spanner wrenches are available to ease (rod) seal or gland cartridge removal without disassembly of the cylinder. **(For rod diameters over 2 1/2".)**

For detailed seal replacement instructions see service bulletin SB0995-M1, M2 and M3.

Rod Dia.	PA-2 Cylinders Only		PL-2 Cylinders Only		Gland Wrench	Spanner Wrench		
	Gland (Symbol 62) Cartridge Kits	Rod Seal Kits	Gland (Sym. 62) Cartridge Kits	Rod Seal Kits				
	Contains Symbols 14, 40, 41, 43 & 45	Contains Symbols 40, 41, 43 & 45	Contains Symbols 14, 40, 41 & 45	Contains Symbols 40, 41 & 45				
1/2	A63210105	A63210305	A63210505	A63210705	Not Required	Not Required		
5/8	A63210108	A63210308	A63210508	A63210708				
1	A63210110	A63210310	A63210510	A63210710				
1 3/8	A63210113	A63210313	A63210513	A63210713				
1 3/4	A63210114	A63210314	A63210514	A63210714				
2	A63210120	A63210320	A63210520	A63210720				
2 1/2	A63210125	A63210325	A63210525	A63210725				
3	A63210130	A63210330	A63210530	A63210730			069596 0000	011677 0000
3 1/2	A63210135	A63210335	A63210535	A63210735			069597 0000	011677 0000
4	A63210140	A63210340	A63210540	A63210740			069598 0000	011678 0000
4 1/2	A63210145	A63210345	A63210545	A63210745	083877 0000	011678 0000		
5	A63210150	A63210350	A63210550	A63210750	069599 0000	011678 0000		
5 1/2	A63210155	A63210355	A63210555	A63210755	069600 0000	011678 0000		

Bore Size	Piston Seal Kits	Piston Seal Kits	Piston Ring Kits
	PA-2 Series	PL-2 Series	PL-2 Series
	Contains 2 Each Symbols: 42, 44 & 47	Contains 2 Each Symbols: 42, 44 & 47	Contains 2 Each Symbols 47 & 4 Each Symbol 48
1	A63211006	A63211007	A63211008
1 1/2	A63211506	A63211507	A63211508
2	A63212006	A63212007	A63212008
2 1/2	A63212506	A63212507	A63212508
3 1/4	A63213206	A63213207	A63213208
4	A63214006	A63214007	A63214008
5	A63215006	A63215007	A63215008
6	A63216006	A63216007	A63216008
7	A63217006	-	-
8	A63218006	A63218007	A63218008
10	A63219006	-	-
12	A63219206	-	-
14	A63219406	-	-

Piston Seal Options

Ring Type Piston

(as shown above)

Supplied as standard on PL-2 series hydraulic cylinders.

Lipseal Type Piston

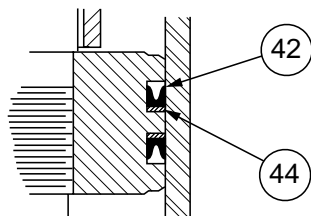

Supplied as standard on PA-2 series air cylinders. Optional for PL-2 series hydraulic cylinders.

Bore Size	Cylinder Body Seal Kits		Tie Rod Torque Specifications (Ft. Lbs.)		
	PA-2 Series	PL-2 Series	PA-2 Series		PL-2 Series
	Contains 2 Each Symbol 47	Contains 2 Each Symbol 47	Steel Cylinder Body	Brass Cylinder Body	
1	A63211010	A63211010	2	1	2
1 1/2	A63215010	A63215010	5	3	5
2	A63220010	A63220010	11	6	11
2 1/2	A63225010	A63225010	11	6	11
3 1/4	A63232010	A63232011	25	18	25
4	A63240010	A63240011	25	18	25
5	A63250010	A63250011	60	45	60
6	A63260010	A63260011	60	45	60
7	A63270010	-	90	-	-
8	A63280010	A63280011	110	80	110
10	A63290010	-	150	115	-
12	A63292010	-	172	150	-
14	A63294010	-	275	230	-

How to Order

Individual seals contained in the kits are available separately; however, we recommend purchasing complete kits because of convenience and lower replacement cost. When ordering seal kits, give part number listed above. To be sure of exact replacement, give serial number of cylinder when ordering replacement kits or seals.

Symbol	Description
14	Gland cartridge
40	Gland wiperseal
41	Gland lipseal
42	Piston lipseal
43	Gland back-up washer
44	Piston back-up washer
45	Gland to head o-ring
47	End seal o-ring
48	Piston ring
62	Gland cartridge kit

Seal Kits for Fluorocarbon Seals

Material: Fluorocarbon

For operating temperature and fluid compatability, see Section C, pages 54 & 55.

Gland and spanner wrenches are available to ease (rod) seal or gland cartridge removal without disassembly of the cylinder. **(For rod diameters over 2 1/2".)**

For detailed seal replacement instructions see service bulletin SB0995-M1, M3 and M5.

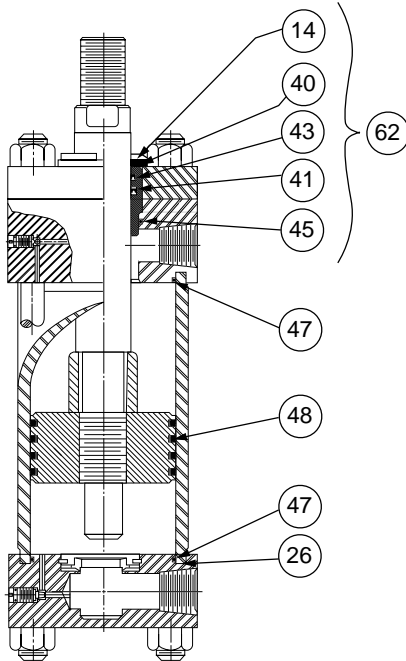

Rod Dia.	PA-2 Cylinders Only		PL-2 Cylinders Only		Gland Wrench	Spanner Wrench		
	Gland (Symbol 62) Cartridge Kits	Rod Seal Kits	Gland (Sym. 62) Cartridge Kits	Rod Seal Kits				
1/2	Contains Symbols 14, 40, 41, 43 & 45 A63220205	Contains Symbols 40, 41, 43 & 45 A63220405	Contains Symbols 14, 40, 41, 43 & 45 A63220605	Contains Symbols 40, 41, 43 & 45 A63220805	Not Required	Not Required		
5/8	A63220208	A63220408	A63220408	A63220808				
1	A63220210	A63220410	A63220610	A63220810				
1 3/8	A63220213	A63220413	A63220613	A63220813				
1 3/4	A63220214	A63220414	A63220614	A63220814				
2	A63220220	A63220420	A63220620	A63220820				
2 1/2	A63220225	A63220425	A63220625	A63220825				
3	A63220230	A63220430	A63220630	A63220830			0695960000	0116770000
3 1/2	A63220235	A63220435	A63220635	A63220835			0695970000	0116770000
4	A63220240	A63220440	A63220640	A63220840			0695980000	0116780000
4 1/2	A63220245	A63220445	A63220645	A63220845	0838770000	0116780000		
5	A63220250	A63220450	A63220650	A63220850	0695990000	0116780000		
5 1/2	A63220255	A63220455	A63220655	A63220855	0696000000	0116780000		

Bore Size	Piston Seal Kits PA-2 Series	Piston Seal Kits PL-2 Series	Piston Ring Kits PL-2 Series
	Contains 2 Each Symbols: 42, 44 & 47	Contains 2 Each Symbols: 42, 44 & 47	Contains 2 Each Symbols 47 & 4 Each Symbol 48
1	A63221006	A63221007	A63221008
1 1/2	A63221506	A63221507	A63221508
2	A63222006	A63222007	A63222008
2 1/2	A63222506	A63222507	A63222508
3 1/4	A63223206	A63223207	A63223208
4	A63224006	A63224007	A63224008
5	A63225006	A63225007	A63225008
6	A63226006	A63226007	A63226008
7	A63227006	-	-
8	A63228006	A63228007	A63228008
10	A63229006	-	-
12	A63229206	-	-
14	A63229406	-	-

Piston Seal Options

Ring Type Piston

(as shown above)
Supplied as standard on PL-2 series hydraulic cylinders.

Lipseal Type Piston

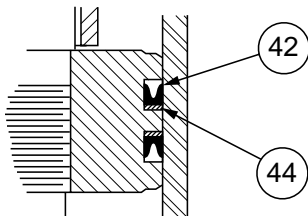

Supplied as standard on PA-2 series air cylinders. Optional for PL-2 series hydraulic cylinders.

Bore Size	Cylinder Body Seal Kits		Tie Rod Torque Specifications (Ft. Lbs.)		
	PA-2 Series	PL-2 Series	PA-2 Series		PL-2 Series
	Contains 2 Each Symbol 47	Contains 2 Each Symbol 47	Steel Cylinder Body	Brass Cylinder Body	
1	A63221020	A63221020	2	1	2
1 1/2	A63221520	A63221520	5	3	5
2	A63222020	A63222020	11	6	11
2 1/2	A63222520	A63222520	11	6	11
3 1/4	A63223230	A63223230	25	18	25
4	A63224030	A63224030	25	18	25
5	A63225030	A63225030	60	45	60
6	A63226030	A63226030	60	45	60
7	A63227030	-	90	-	-
8	A63228030	A63228030	110	80	110
10	A63229030	-	150	115	-
12	A63229230	-	172	150	-
14	A63229430	-	275	230	-

How to Order

Individual seals contained in the kits are available separately; however, we recommend purchasing complete kits because of convenience and lower replacement cost. When ordering seal kits, give part number listed above. To be sure of exact replacement, give serial number of cylinder when ordering replacement kits or seals.

In the PN Series you get all the cost saving benefits and features of the popular heavy duty PA-2 Series air cylinder including...

- Bolt On Rod Gland Assembly for positive no leak sealing.
 - Piston rod, hard chrome plated and case hardened steel
 - High strength rolled thread Piston Rod Stud
 - Steel tube cylinder body with chrome-plated micro finish bore
- PLUS the innovative "NON-LUBE" feature which further increases your benefits of lower operating and maintenance costs.

Standard Specifications

- Heavy Duty Service – ANSI/(NFPA) T3.6.7R2-1996 Mounting Dimensions Standards.
 - Standard Construction – Square Head – Tie Rod Design.
 - Standard Temperature – -10°F. to +165°F.
 - Standard Fluid – Filtered Air.
 - Strokes – Available in any Practical Stroke Length.
 - Cushions – Optional at either end or both ends of stroke. "Float Check" at cap end.
- In line with our policy of continuing product improvement, specifications in this catalog are subject to change.*

Seal Kits

PN Series

Gland Cartridge Kit

Rod Size	Consisting of Symbol 14, 40, 41, 45, 131 & 132
5/8	A63250108
1	A63250110
1 3/8	A63250113
1 3/4	A63250114
2	A63250120
2 1/2	A63250125
3	A63250130
3 1/2	A63250135
4	A63250140
4 1/2	A63250145
5	A63250150
5 1/2	A63250155

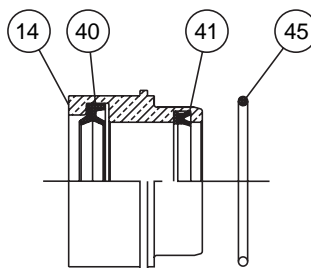

Rod Seal Kit

Rod Size	Consisting of Symbol 40, 41, 45, 131 & 132
5/8	A63250308
1	A63250310
1 3/8	A63250313
1 3/4	A63250314
2	A63250320
2 1/2	A63250325
3	A63250330
3 1/2	A63250335
4	A63250340
4 1/2	A63250345
5	A63250350
5 1/2	A63250355

See Detail "A"

See Detail "B"

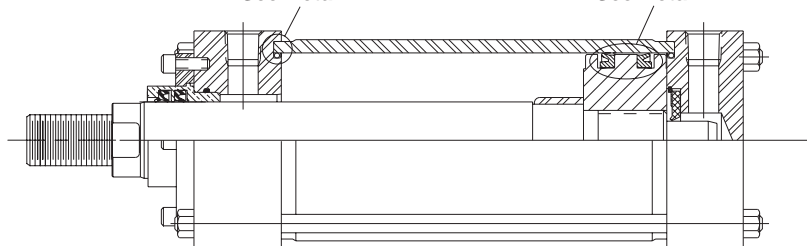

Service kits of expendable parts for PN Series fluid power cylinders are stocked in principal industrial locations across the U.S.A. and other countries. For prompt delivery and complete information, contact your nearest distributor.

Standard Seals — Service Kits contain seals of Buna-N elastomers for standard fluid service. In addition to standard seals, each kit includes the special composite components ready for installation. These seals are suitable for use when air is the operating medium

The recommended operating temperature range for Class 1 seals is -10° F to + 165°F.

Bore Size	Piston Seal Kit Consisting of 2 Ea. Symbol 42, 129*, 130* & 47	Cylinder Body Seal Kit Consisting of 2 Ea. Symbol 47
1 1/2	A63251520	A63215010
2	A63252020	A63220010
2 1/2	A63252520	A63225010
3 1/4	A63253220	A63232010
4	A63254020	A63240010
5	A63255020	A63250010
6	A63256020	A63260010
7	A63257020	A63270010
8	A63258020	A63280010
10	A63259020	A63290010
12	A63259220	A63292010
14	A63259420	—

*14" bore only

Detail "A"

Detail "B"

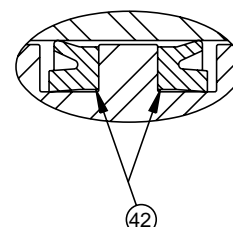
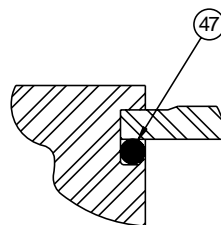

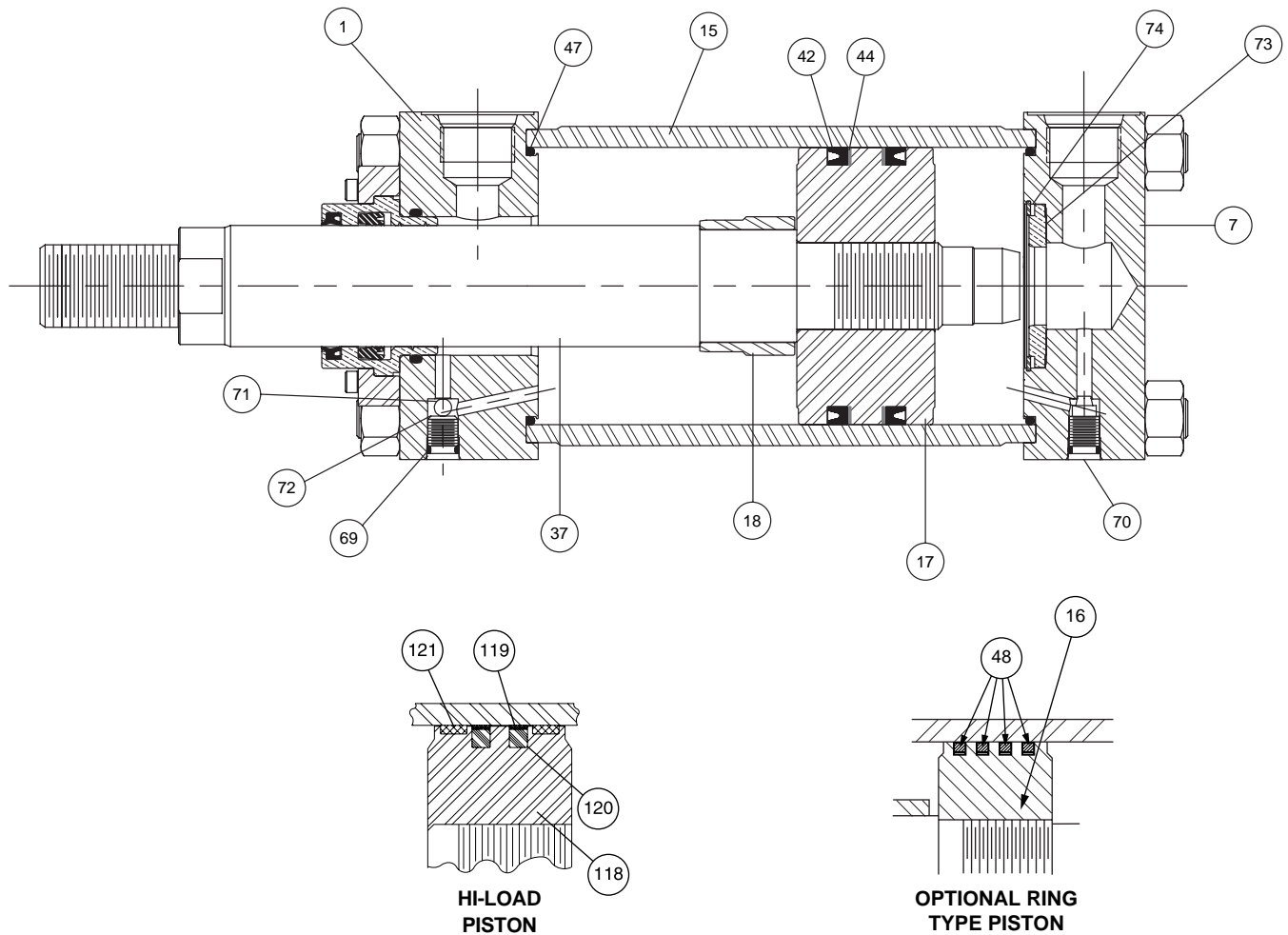

Parts List — 1 1/2" through 6" Bore Sizes

Symbol	Description
1	Head
7	Cap
15	Cylinder body
16	Piston, ring type
17	Piston, lipseal type
18	Cushion sleeve, rod head cushion
37	Piston rod, single rod type
42	Lipseal, piston
44	Back-up washer, piston
47	O-ring, cylinder tube to head and cap seal
48	Piston ring, iron
69	O-ring, cushion adjustment and check valve plug screw
70	Needle, cushion adjustment valve
71	Ball, cushion check valve
72	Plug screw, cushion check valve
73	Bushing, float check, cushion on cap end
74	Retaining ring, float check cushion bushing
118	Piston, Hi-Load type
119	Outer Ring
120	Inner Ring
121	Wear Ring

Piston and Rod Assemblies

Factory assembled piston and rod assemblies (that include seals for piston type specified) are recommended.

Seal Kits

Gland Seal Kits Contain Gland and Seals for PH-2 Series
(Includes symbols 14, 40, 41, 43 and 45.)

Rod Seal Kits Contain Rod Seals for PH-2 Series
(Includes symbols 40, 41, 43 and 45.)

Lipseal Kits Contain Piston Lipseals™ and Body End Seals
(Includes two each of symbols 42, 44 and 47.)

Body Seal Kits Contain Cylinder Body End Seals
(Includes two each of symbol 47.)

Piston Ring Kits Contain Piston Rings
(Includes four each symbol 48 and two each of 47.)

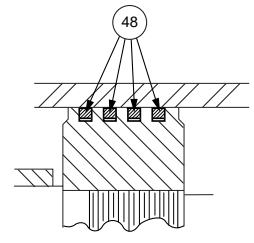
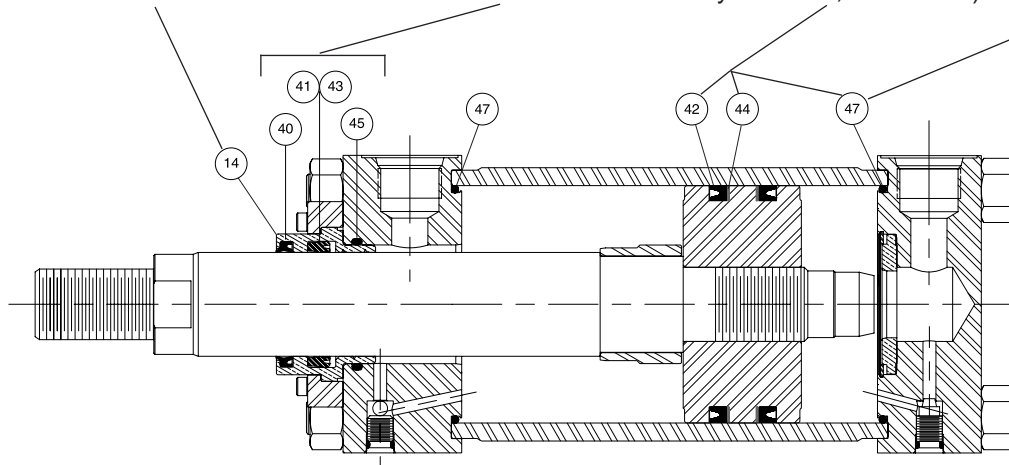

OPTIONAL RING TYPE PISTON

Standard Seals

Cylinders built with standard seals contain Buna-N seals except for the piston rod seal which is polyurethane. They are suitable for use with air, nitrogen or hydraulic oil. The recommended operating temperature range for standard seals is -10° F (-23° C) to +165° F (+74° C).

Fluorocarbon Seals

Fluorocarbon seals can be supplied, on request, and are especially suitable for some fire resistant fluids as shown in the table in Section C for elevated temperature service.

When using Fluorocarbon seals for high temperature service or fluid compatibility within a temperature range of -10° F (-23° C) to +250° F (+121° C) specify Fluorocarbon seals. For elevated temperature service above +250° F (+121° C) specify Fluorocarbon seals plus a non-studded piston rod end thread and a pinned piston to rod connection. This recommendation should also be followed when ordering spare

piston and rod assemblies. Fluorocarbon seals can operate up to a maximum of +400° F (+204° C) with reduced service life.

WARNING!

The piston rod stud and the piston rod to piston threaded connections are secured with an anaerobic adhesive which is temperature sensitive. Cylinders ordered with Fluorocarbon seals are assembled with anaerobic adhesive having a maximum operating temperature rating of +250° F (+121° C). Cylinders ordered with all other seal compounds are assembled with anaerobic adhesive a maximum operating temperature rating of +165° F (+74° C). These temperature limitations must be strictly followed to prevent loosening of the threaded connections. When cylinders are intended to be used above +250° F (+121° C) specify a non-studded piston rod end thread and a pinned piston to rod connection.

Rod Gland and Rod Seal Kits

Rod Dia.	Standard Seals		Fluorocarbon Seals		Retainer Screw Torque Inch Lbs.
	Rod Gland Cartridge Kits	Rod Seal Kits	Rod Gland Cartridge Kits	Rod Seal Kits	
5/8	A63230A08	A63230C08	A63230B08	A63230D08	24
1	A63230A10	A63230C10	A63230B10	A63230D10	24
1 3/8	A63230A13	A63230C13	A63230B13	A63230D13	24
1 3/4	A63230A14	A63230C14	A63230B14	A63230D14	24
2	A63230A20	A63230C20	A63230B20	A63230D20	120
2 1/2	A63230A25	A63230C25	A63230B25	A63230D25	120
3	A63230A30	A63230C30	A63230B30	A63230D30	240
3 1/2	A63230A35	A63230C35	A63230B35	A63230D35	240
4	A63230A40	A63230C40	A63230B40	A63230D40	240

Cylinder Body and Piston Seal Kits

Bore Size	Standard Seals			Fluorocarbon Seals			Tie Rod Torque Specification lb-ft
	Cylinder Body Seal Kits	Piston Ring Kit	Piston (Lipseal) Seal Kit	Cylinder Body Seal Kits	Piston Ring Kit	Piston (Lipseal) Seal Kit	
1 1/2	A63215010	A63211508	A63211507	A63221520	A63221508	A63221507	18-19
2	A63220010	A63212008	A63212007	A63222020	A63222008	A63222007	45-49
2 1/2	A63225010	A63212508	A63212507	A63222520	A63222508	A63222507	45-49
3 1/4	A63232011	A63213208	A63213207	A63223206	A63223208	A63223207	120-124
4	A63240011	A63214008	A63214007	A63224006	A63224008	A63224007	131-135
5	A63250011	A63215008	A63215007	A63225006	A63225008	A63225007	312-316
6	A63260011	A63216008	A63216007	A63226006	A63226008	A63226007	528-544

PH-3 Series, 7" & 8" Bore Hydraulic Cylinders

Parts Identification and Maintenance Instructions

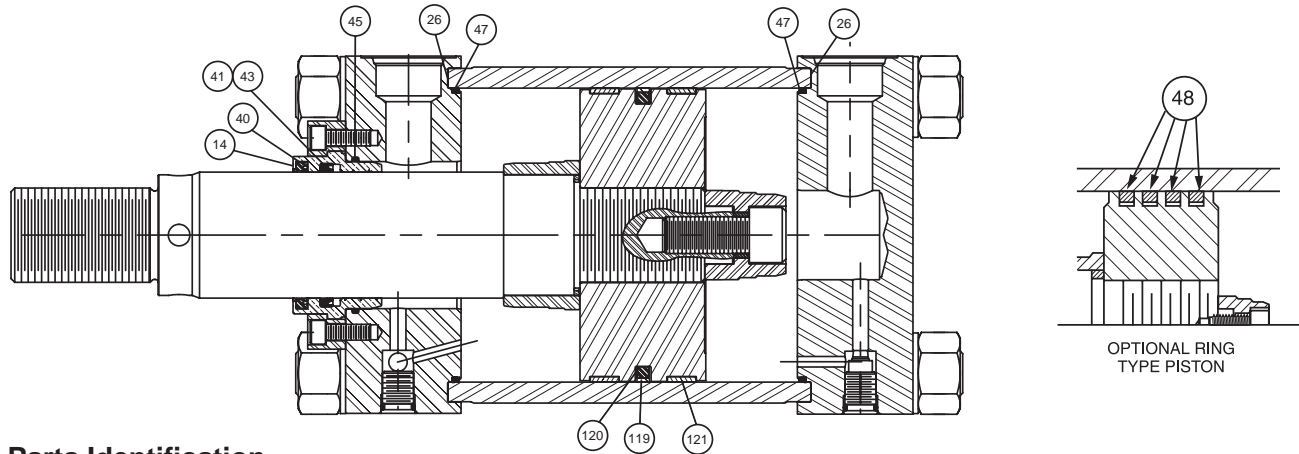

Parts Identification

Sym. No.	Description	Sym. No.	Description
14	Rod Gland	47	End Seal O-Ring
40	Rod Wiperseal	48	Piston Ring
41	Rod Lipseal	119	Outer Ring
43	Rod Seal Back-up Washer	120	Inner Ring
26	End Seal Back Up Washer	121	Wear Ring
45	Gland to Head O-Ring		

Fluorocarbon Seals – The service kits contain fluorocarbon seals and are especially suited for elevated temperature service or for some fire resistant fluids (for specific fluids not listed in current catalog consult factory). Fluorocarbon seals should be used for high temperature service within a temperature range of -10°F (-23°C) to +250°F (+120°C) the cylinder must be manufactured with a pinned piston to rod connection.

Warning – The piston rod to piston threaded connection is secured with an anaerobic adhesive which is temperature sensitive. Cylinders specified with Fluorocarbon seals are assembled with anaerobic adhesive having a maximum operating temperature range of +165°F (+74°C). These temperature limitations are necessary to prevent the possible loosening of the threaded connections. Cylinders originally manufactured with standard seals that will be exposed to ambient temperature above +165°F (+74°C) must be modified for higher temperature service. Contact the factory immediately and arrange for the piston to rod and the stud to piston rod connections to be properly reassembled to withstand the higher temperature service.

Service kits of expendable parts for fluid power cylinders are stocked in principal industrial locations across the U.S.A. and other countries. For prompt delivery and complete information, contact your nearest Schrader Bellows distributor or office.

Service kits of expendable parts for fluid power cylinders are available for either standard seals, fluorocarbon seals or H.W.C.F. seals which are intended to use with highwater content fluids.

Standard Seals – Standard Seal Service Kits contain P.T.F.E., nitrile and polyurethane seals. These seals are suitable for use when hydraulic (mineral-type) oil is the operating medium. The recommended operating temperature range for standard seals is -10°F (-23°C) to +165°F (+74°C).

Rod Gland and Rod Seal Kits

Rod Dia.	Standard Seals		Fluorocarbon Seals		Retainer Screw Torque
	Rod Gland Cartridge Kits (Contains: 1 Each Sym. #14, 40, 41, & 45)	Rod Seal Kits (Contains: 1 Each Sym. #40, 41, & 45)	Rod Gland Cartridge Kits (Contains: 1 Each Sym. #14, 40, 41, 43, & 45)	Rod Seal Kits (Contains: 1 Each Sym. #40, 41, 43, & 45)	
3	A63230A30	A63230C30	A63230B30	A63230D30	23-24 lb-ft
3 1/2	A63230A35	A63230C35	A63230B35	A63230D35	23-24 lb-ft
4	A63230A40	A63230C40	A63230B40	A63230D40	41-43 lb-ft
5	A63230A50	A63230C50	A63230B50	A63230D50	41-43 lb-ft
5 1/2	A63230A55	A63230C55	A63230B55	A63230D55	65-68 lb-ft

Cylinder Body and Piston Seal Kits

Bore Size	Standard Seals			Fluorocarbon Seals			Tie Rod Torque Specification
	Cylinder Body Seal Kits (Contains: 2 Each Sym. #26 & 47)	Piston Ring Kits (Contains: 4 Each Sym. #48 & 2 Each Sym. #26 & 47)	Hi-Load Piston Seal Kits (Contains: 2 Each Sym. #26, 47, & 121 2 Each Sym. #119 & 120)	Cylinder Body Seal Kits (Contains: 2 Each Sym. #26 & 47)	Piston Ring Kits (Contains: 4 Each Sym. #48 & 2 Each Sym. #26 & 47)	Hi-Load Piston Seal Kits (Contains: 2 Each Sym. #26, 47, & 121 2 Each Sym. #119 & 120)	
7	A63307031	A63307001	A63307021	A63307035	A63307005	A63307025	800-816 lb-ft
8	A63308031	A63308001	A63308021	A63308035	A63308005	A63308025	1168-1184 lb-ft

To Service Rod Gland Seals – The rod gland cartridge is removable without disassembly of the cylinder on all PH-3 Series 7" & 8" bore hydraulic cylinders. To remove the gland, loosen the retainer screws and remove the gland retainer. It is recommended that the used gland be replaced by a complete gland cartridge kit. Later the used gland can be inspected, and if the bearing surface is still satisfactory and not out-of-round, it can be repacked with replacement seals and stored for future use.

Assemble seals for the PH-3 Series 7" & 8" bore gland by installing the rod wiperseal and rod lipseal in their proper grooves. Install head-to-gland "O" ring in its proper groove. Lubricate all seals.

THE SEALS ARE PRESSURE-ACTUATED, SO NO FURTHER ADJUSTMENTS ARE NECESSARY.

To Service The Piston Seals — Disassemble the cylinder completely; remove the old seals and clean all of the parts. The cylinder bore and the piston should then be examined for evidence of scoring. If either is damaged, it should be replaced. The piston seal is either cast iron rings, or hi-load P.T.F.E. type.

Iron piston rings seldom need replacement. If the rings show no signs of damage or abnormal wear, they may be reused. To install piston and rings, collapse the rings one at a time, while inserting the piston into the cylinder body, using a light oil to aid this process.

The hi-load piston is supplied with one continuous P.T.F.E. outer ring, Symbol 119, which is preloaded by a synthetic rubber inner ring, Symbol 120, and two split fabric-phenolic wear rings, Symbol 121. To service the hi-load piston, remove old seals and wear rings and clean all piston surfaces. Install the inner ring in groove as shown. Install the wear ring in the

longer groove at each end of piston, also as shown. Heat the P.T.F.E. outer ring in boiling water and stretch it by hand until it will fit over the O.D. of the wear ring. Push outer ring over the wear ring and into the seal groove. With outer ring in its groove, compress it with ring compressor or use a starting sleeve having an I.D. same size as cylinder bore and tapered at one end.

To Replace Piston — If the piston or piston rod is badly scored or otherwise damaged, they should be replaced as a complete assembly. To order a piston and rod assembly, specify serial number, bore size, stroke and model number as shown on the cylinder name plate.

Cylinder Reassembly — O-rings, Symbol 47, and back-up washers, Symbol 26, should be lightly coated with lubricant, then worked into place into the cap by hand. Cylinder body can then be assembled to the cap by rocking it down over the seal until the end of the cylinder body is metal-to-metal contact with the cap. Install O-ring, Symbol 47, and back-up washers, Symbol 26, in head. Head is then fitted over the piston rod and assembled to cylinder body. Rock gently into place until body and head are in metal-to-metal contact.

Install tie rods in holes provided in cap and thread them into the tapped holes in the head. One cap end mounting styles the tapped holes are in the cap. Install the tie rod nuts and tighten finger tight.

Inspect the surface of the piston rod for scratches, dents, raised burrs or other damage. A damaged piston rod will quickly ruin any seal through which it moves and should be replaced. Slide the gland with its seals over the piston rod until it seats against the cavity in the head. Install the gland retainer and retainer screws. Torque the tie rod nuts and gland retainer screws to the torque level shown on the previous page.

Parts Identification

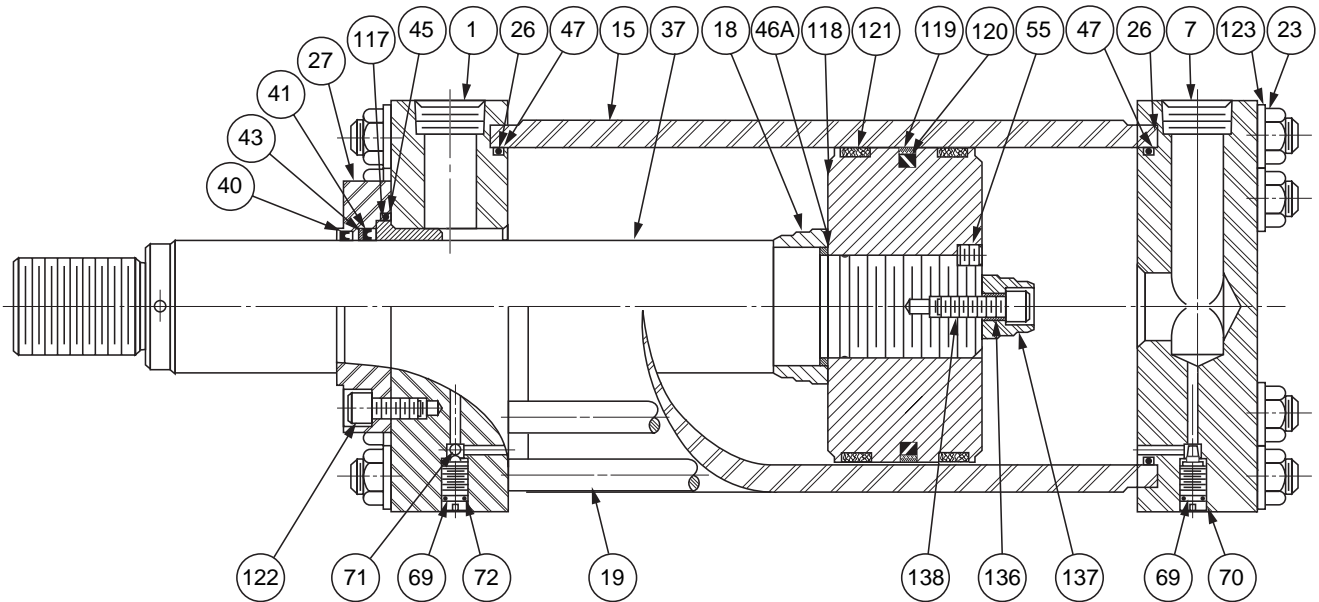

Sym. No.	
1	Head
7	Cap
15	Cylinder Body
16	Piston Body – Ring Type Piston
17	Piston Body – Lipseal
18	Cushion Sleeve
19	Tie Rod
23	Tie Rod Nut – Non-Locking
26	Back-Up Washer, Cylinder Body
27	Retainer
37	Piston Rod
40	Wiperseal
41	Rod Seal (Polypak)
42	Lipseal, Piston
43	Back-Up Washer, Polypak
44	Back-Up Washer, Lipseal
45	O-Ring, Gland to Head
46A	Cushion Sealing Ring

Sym. No.	
47	O-Ring Cylinder Body
48	Piston Ring
55	Piston Lock Pin
69	O-Ring, Cushion Adj. & Check Screws
70	Cushion Adjusting Needle Screw
71	Check Valve Ball
72	Check Valve Screw
117	Rod Bearing
118	Piston Body – Hi-Load
119	Outer Piston Ring
120	Inner Piston Ring
121	Wear Ring
122	Retainer Bolt
123	Washer, Tie Rod Nut
136	Spacer, Cushion
137	Cushion Spear, Detachable
138	Bolt, Cushion Spear

**Optional
Piston
Lipseal Kit**

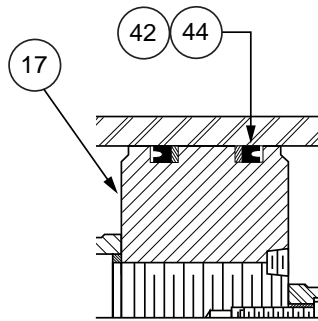

**Optional
Piston
Ring Kit**

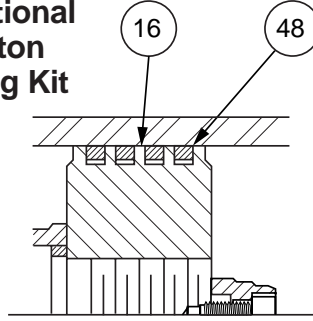

**Standard
Hi-Load
Piston
Seal Kit**

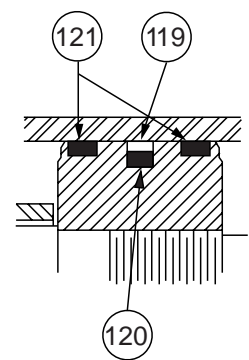

Operating Fluids and Temperature Range – Fluidpower cylinders are designed for use with pressurized air, hydraulic oil and fire resistant fluids, in some cases special seals are required.

Standard Seals

Buna-N seals are supplied on all standard pneumatic and hydraulic cylinders. They are suitable for use with pressured air, nitrogen, hydraulic oil, water-in oil emulsions or water glycol fluids. The recommended operating temperature range for Buna-N seals is -10°F. (-23°C.) to +165°F (+74°C.).

Fluorocarbon Seals

Fluorocarbon seals can be supplied, on request, and are especially suitable for some fire resistant fluids as shown in the table in Section C, or for elevated temperature service.

When using Fluorocarbon seals for high temperature service or fluid compatibility within a temperature range of -10°F. (-23°C) to +250°F. (+121°C) specify Fluorocarbon seals.

For elevated temperature service above +250°F. (+121°C) specify Fluorocarbon seals plus a non-studded piston rod end thread and a pinned piston to rod connection. This recommendation should also be followed when ordering spare piston and rod assemblies. Fluorocarbon seals can operate up to a maximum of +400°F. (+204°C) with reduced service life.

The piston rod stud and the piston rod to piston threaded connections are secured with an anaerobic adhesive which is temperature sensitive. Cylinders ordered with Fluorocarbon seals are assembled with anaerobic adhesive having a maximum operating temperature rating of +250°F. (+121°C). Cylinders ordered with all other seal compounds are assembled with anaerobic adhesive having a maximum operating temperature rating of +165°F. (+74°C). These temperature limitations must be strictly followed to prevent loosening of the threaded connections. When cylinders are intended to be used above +250°F. (+121°C) specify a non-studded piston rod end thread and a pinned piston to rod connection.

Bore	Rod Dia.	Rod Seal Kits		Rod Seal Kits Including Bearing	
		Contains Symbol 40, 41, 43, 45		Contains Symbol 40, 41, 43, 45 & 117	
		Standard Kit No.	Fluorocarbon Kit No.	Standard Kit No.	Fluorocarbon Kit No.
10	4 1/2	A63300451	A63300455	A63310451	A63310455
	7	A63300701	A63300705	A63310701	A63310705
	5	A63300501	A63300505	A63310501	A63310505
	5 1/2	A63300551	A63300555	A63310551	A63310555
12	5 1/2	A63300551	A63300555	A63310551	A63310555
	8	A63300801	A63300805	A63310801	A63310805
14	7	A63300701	A63300705	A63310701	A63310705
	10*	A63301001	A63301005	A63311001	A63311005
	8*	A63300801	A63300805	A63310801	A63310805

*NOTE: For 16", 18" and 20" Bore PH-3 Cylinders with 8" and 10" rods use the seal kits listed above for 14" Bore PH-3 with 8" and 10" rods.

Cylinder Bore Size	Tie Rod Torque
10"	700 - 716 lb-ft
12"	1320 - 1336 lb-ft
14"	1000 - 1016 lb-ft
16"/18"/20"	2900 - 3000 lb-ft

Retainer Bolt Torque for Cylinders with Round Gland Retainer

Torque values are for bolts installed with lubrication.

Screw Size	Torque
1/2"	100 - 105 lb-ft
5/8"	185 - 194 lb-ft
3/4"	330 - 346 lb-ft

Bore	Piston Ring Kit†		Piston Lipseal Kit†	
	Contains 4 Ea. Sym. 48, 2 Ea. Sym. 47 & 26		Contains 2 Ea. Sym. 42, 44, 47 & 26	
	Standard Kit No.	Fluorocarbon Kit No.	Standard Kit No.	Fluorocarbon Kit No.
10	A63310001	A63310005	A63310011	A63310015
12	A63312001	A63312005	A63312011	A63312015
14	A63314001	A63314005	A63314011	A63314015

Bore	Hi Load Piston Seal Kit†		Cylinder Body Seal Kit†	
	Contains 1 Ea. Sym. 119, 120, 2 Ea. Sym. 121, 47 & 26		Contains 2 Ea. Sym. 47 & 26	
	Standard Kit No.	Fluorocarbon Kit No.	Standard Kit No.	Fluorocarbon Kit No.
10	A63310021	A63310025	A63310031	A63310035
12	A63312021	A63312025	A63312031	A63312035
14	A63314021	A63314025	A63314031	A63314035

†For 16", 18" and 20" bore piston kits – consult factory.

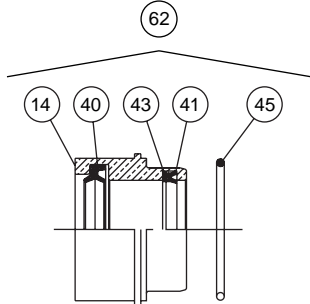
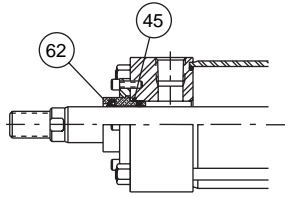

For rod dia.
 2 1/2" and below

GLAND CARTRIDGE KIT

RG (symbol 62) contains 1 each of the following:
 symbol 14, gland
 symbol 40, rod Wiperseal
 symbol 41, rod Lipseal
 symbol 43, back-up washer for rod gland lipseal*
 symbol 45, O-ring gland to head seal.

ROD SEAL KIT

Contains 1 each of the following:
 symbol 40, rod Wiperseal
 symbol 41, rod Lipseal**
 symbol 41, rod Polypack Seal**
 symbol 43, backup washer for rod Lipseal*
 symbol 45, O-ring, gland to head seal.

*Required only for 1/2" dia. rod and for Class 5 service, 3" dia. rod and larger.

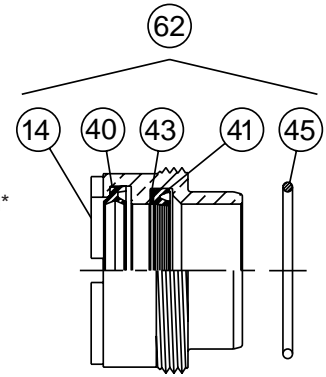

For rod dia. 3" and over

Service kits of expendable parts for air and hydraulic cylinders are stocked in principal industrial locations across the U.S.A. and other countries. For prompt delivery and complete information, contact your nearest Schrader Bellows distributor.

Service kits of expendable parts for fluid power cylinders are available for either Class 1 or Class 5 fluid service.

Standard Seals — Class 1 Service Kits are standard, and contain polyurethane seals. Class 1 Service Kits are suitable for use when air and hydraulic (mineral type) oil are the operating media.

The recommended operating temperature range for Class 1 seals is -10°F (-23°C) to +165°F (+74°C).

Fluorocarbon Seals — Class 5 Service Kits contain Fluorocarbon seals and are especially suited for elevated temperature service or for some fire resistant fluids (for specific fluids not listed in the latest Schrader Bellows Actuator Catalog, consult factory). Fluorocarbon seals (Class 5) should be used for high temperature service within a temperature range of -10°F (-23°C) to +250°F (+121°C). Fluorocarbon seals may be operated to +400°F (+204°C) with limited service life. For temperatures above +250°F (+121°C) the cylinder must be manufactured with a non-studded piston rod end thread and a pinned piston to rod connection.

Warning — The piston rod stud and the piston rod to piston threaded connections are secured with an anaerobic adhesive which is temperature sensitive. Cylinders specified with fluorocarbon seals are assembled with anaerobic adhesive having a maximum operating temperature rating of +250°F (+121°C). Cylinders specified with all other seal compounds are assembled with anaerobic adhesive having a maximum operating temperature rating of +165°F (+74°C). These temperature limitations are necessary to prevent the possible loosening of the threaded connections. Cylinders originally manufactured with Class 1 seals (Buna-N) that will be exposed to ambient temperatures above +165°F (+74°C) must be modified for higher temperature service. Contact the factory immediately and arrange for the piston to rod and the stud to piston rod connections to be properly reassembled to withstand the higher temperature service.

** This seal kit contains both a poly pack and a serrated lipseal as the primary piston rod seal symbol (41). Cylinders manufactured before the spring of 1999 contained the poly pack seal while cylinders built after this date contained the serrated seal with a larger cross-section. If servicing a gland which contained a poly pack rod seal, replace it with the poly pack provided. If the gland contained a serrated seal, replace it with the serrated seal provided. If it is desired to use the serrated seal regardless of the original construction order kit no. A63210510.

Rod Dia.	PL-2 Cylinders — Class 1		Rod Dia.	Fluorocarbon PL-2 Series Cylinders — Class 5	
	Gland (Symbol 62) Cartridge Kits	Rod Seal Kits		Gland (Symbol 62) Cartridge Kits	Rod Seal Kits
	Contains Symbols 14, 40, 41, 43† & 45	Contains Symbols 40, 41, 43† & 45		Contains Symbols 14, 40, 41, 43† & 45	Contains Symbols 40, 41, 43† & 45
1/2	A63210505	A63210705	1/2	A63220605	A63220805
5/8	A63210508	A63210708	5/8	A63220608	A63220808
1	A63210510	A63210710	1	A63220610	A63220810
1 3/8	A63210513	A63210713	1 3/8	A63220613	A63220813
1 3/4	A63210514	A63210714	1 3/4	A63220614	A63220814
2	A63210520	A63210720	2	A63220620	A63220820
2 1/2	A63210525	A63210725	2 1/2	A63220625	A63220825
3	A63210530	A63210730	3	A63220630	A63220830
3 1/2	A63210535	A63210735	3 1/2	A63220635	A63220835
4	A63210540	A63210740	4	A63220640	A63220840
4 1/2	A63210545	A63210745	4 1/2	A63220645	A63220845
5	A63210550	A63210750	5	A63220650	A63220850
5 1/2	A63210555	A63210755	5 1/2	A63220655	A63220855

†Required only for 1/2" diameter rod and Class 5 service 3" diameter rod and larger.

Service Assemblies and Seal Kits

Service Assembly Kits and Seal Kits for SHM cylinders simplify the ordering and maintenance processes. They contain sub-assemblies which are ready for installation, and are supplied with full instructions. When ordering Service Assemblies and Seal Kits, please refer to the identification plate on the cylinder body, and supply the following information:

Serial Number - Bore - Stroke - Model Number - Fluid Type

Key to Part Numbers

- 1 Head
- 7 Cap
- 14 Piston rod bushing
- 15 Cylinder body
- 17 Piston
- 18 Cushion sleeve
- 19 Tie rod
- 23 Tie rod nut
- 26 Back-up washer (not 25-50mm bore cylinders)

- 70f O-ring – needle screw
- 71 Ball – cushion check valve
- 72 Cushion check valve screw
- 73 Floating cushion bushing
- 74 Retaining ring for cushion bushing
- 125 Standard piston seal
- 126 Energizing ring for standard seal 125
- 127 Wear ring for standard piston

¹Not illustrated

²In some cases, the adjusting screw is installed in a cartridge.

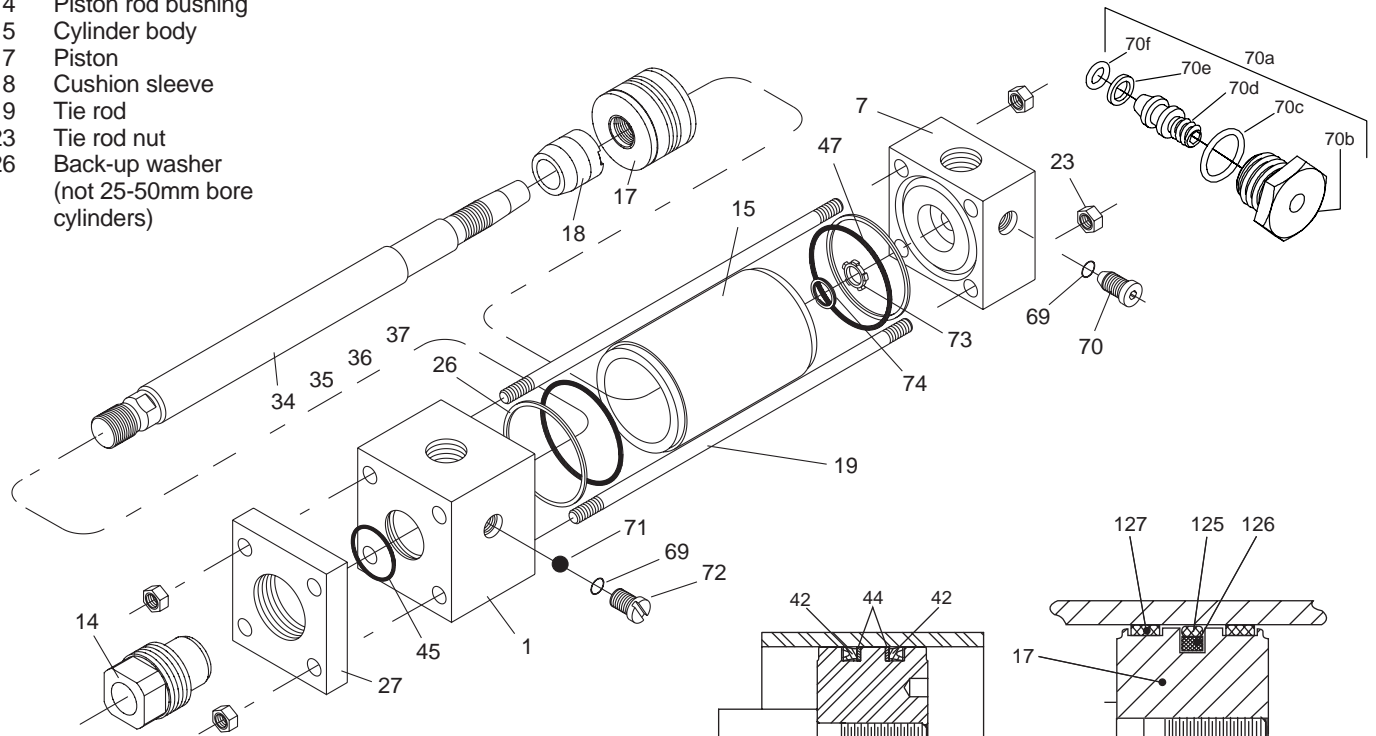

- 27 Retainer
- 34 Piston rod – single rod, no cushion
- 35 Piston rod – single rod, cushion at head end
- 36 Piston rod – single rod, cushion at cap end
- 37 Piston rod – single rod, cushion at both ends
- 40 Wiperseal – for 14 and 122
- 41 Lipseal – for 14
- 42 Lipseal, Piston 25-40mm bores only
- 43 Back-up washer, bushing lipseal 41 (not Group 1 seals)
- 44 Back-up washer, piston lipseal
- 45 O-ring – bushing/head
- 47 O-ring – cylinder body
- 57¹ Piston rod – double rod, no cushion
- 58¹ Piston rod – double rod, cushion one end
- 60¹ Piston rod – double rod, no cushion
- 61¹ Piston rod – double rod, cushion one end
- 69 O-ring – needle valve and check valve screws
- 70² Needle valve, cushion adjustment
- 70a² Needle valve, cushion adjustment – cartridge type
- 70b Cartridge screw
- 70c O-ring – cartridge screw
- 70d Needle screw
- 70e Back-up washer – needle screw

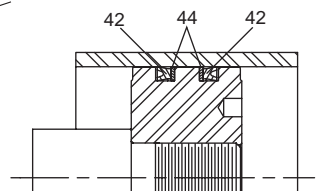

Piston 25mm, 32mm and 40mm bore

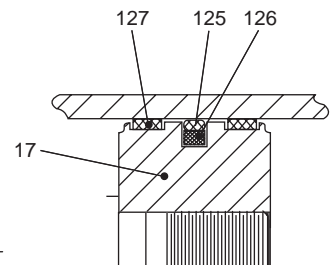

Piston 50mm bore and larger

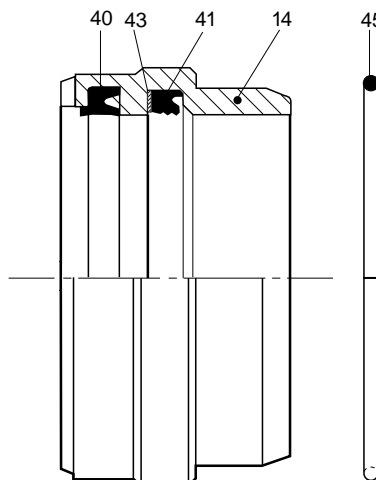

Piston Rod Bushing and Seals



Seal Kits**Metric Hydraulic Cylinders
SHM Series****Contents and Part Numbers of Seal Kits
for Pistons and Rod Bushings**

(see key to part numbers opposite)

Gland Kit – Rod Bushing and Seals Contain items 14, 40, 41, 43, 45. Where the original bushing incorporates a bushing drain, please consult the factory.

Rod Seal Kit – Bushing Seals Contain items 40, 41, 43, 45

Rod ∅	Bushing Assembly		Rod Seal Kit	
	Standard	Fluorocarbon	Standard	Fluorocarbon
12	B732-944	B732-1100	B732-966	B732-1112
14	B732-945	B732-1101	B732-967	B732-1113
18	B732-946	B732-1102	B732-968	B732-1114
22	B732-947	B732-1103	B732-969	B732-1115
28	B732-948	B732-1104	B732-970	B732-1116
36	B732-949	B732-1105	B732-971	B732-1117
45	B732-950	B732-1106	B732-972	B732-1118
56	B732-951	B732-1107	B732-973	B732-1119
70	B732-952	B732-1108	B732-974	B732-1120
90	B732-953	B732-1109	B732-975	B732-1121
110	B732-954	B732-1110	B732-976	B732-1122
140	B732-955	B732-1111	B732-977	B732-1123

Body Kit – Cylinder Body End Seals Contain two each of items 47, 26 (no backup washer in 25-50mm bore).

Piston Kit**B-Style Piston Kit - (includes Cylinder Body End Seals)**

Contains two each of items 47, 26 (no backup washer in 25mm-50mm bores), two of item 127, and one each of items 125 & 126

Lipseal Piston Kit - (includes Cylinder Body End Seals)

Contains two each of items 42, 44 & 47.

Bore ∅	Body Seal Kit	
	Standard	Fluorocarbon
25	B732-956	B732-1124
32	B732-957	B732-1125
40	B732-958	B732-1126
50	B732-959	B732-1127
63	B732-960	B732-1128
80	B732-961	B732-1129
100	B732-962	B732-1130
125	B732-963	B732-1131
160	B732-964	B732-1132
200	B732-965	B732-1133

Bore ∅	Piston Seal Kits [†]		
	B-Style Piston Seals		Piston Lipseals™
	Standard	Fluorocarbon	Fluorocarbon*
25	B732-1169	B732-1179	B732-1189
32	B732-1170	B732-1180	B732-1190
40	B732-1171	B732-1181	B732-1191
50	B732-1172	B732-1182	N/A
63	B732-1173	B732-1183	
80	B732-1174	B732-1184	
100	B732-1175	B732-1185	
125	B732-1176	B732-1186	
160	B732-1177	B732-1187	
200	B732-1178	B732-1188	

[†] Piston Lipseals were made standard in 25mm - 40mm bores beginning in June 2006. Carefully check the model number for a 'B' - B-Style or 'L' - Lipseal Style piston before specifying a piston seal kit.

* Piston Lipseal Kits contain group 5 seals that are also suitable for group 1 service.

Tie Rod Torques

Bore ∅	Tie Rod Torque Nm
25	4.5-5.0
32	7.6-9.0
40	19.0-20.5
50	68-71
63	68-71
80	160-165
100	160-165
125	450-455
160	815-830
200	1140-1155

The tie rod torque values listed in this table are intended for SHM series cylinders having a pressure envelope pressure rating of 210 bars or 3000 p.s.i. Consult factory for tie rod torque of SHM series cylinders having a higher pressure rating.

Repairs

Although SHM cylinders are designed to make on-site maintenance or repairs as easy as possible, some operations can only be carried out in our factory. It is standard policy to fit a cylinder returned to the factory for repair with those replacement parts which are necessary to return it to 'as good as new' condition. Should the condition of the returned cylinder be such that repair would be uneconomical, you will be notified.

Parts Identification

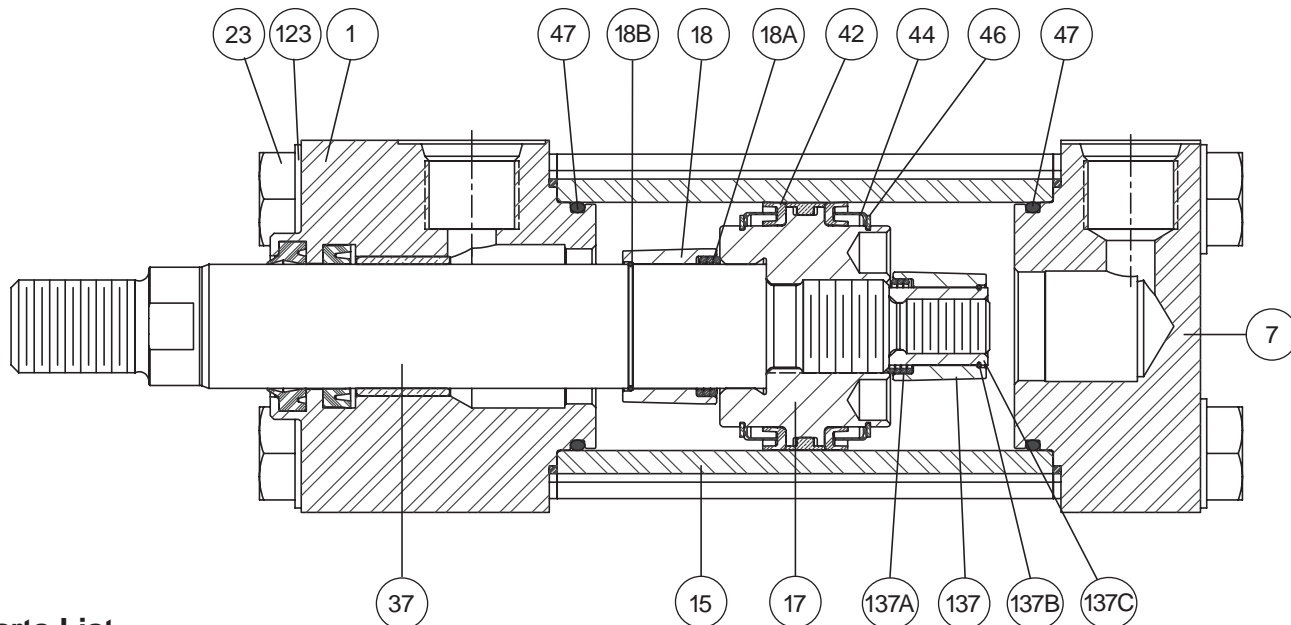

Parts List

Symbol	Description
1	Head
7	Cap
15	Cylinder Body
17	Piston, lipseal type
18	Cushion sleeve, head end cushion
18A	Cushion check spring, head end cushion
18B	Cushion retaining wire, head end cushion
23	Bolt, head and cap to body
37	Piston rod, single rod type
42	Lipseal, piston
44	Anti-roll ring, piston lipseal
46	Retaining ring, piston lipseal
47	O-ring, cylinder body to head and cap seal
118	Piston, Hi-Load type*
119	Outer ring
120	Inner ring
121	Wear ring
123	Washer
137	Cushion sleeve, cap end cushion
137A	Cushion check spring, cap end cushion
137B	Cushion retaining wire, cap end cushion
137C	Cushion support, cap end cushion

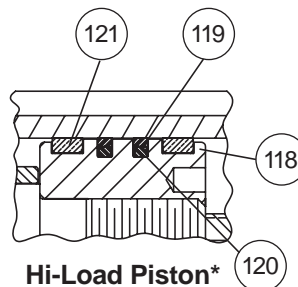

Hi-Load Piston*

Piston and Rod Assemblies

Factory assembled piston and rod assemblies (that include seals for the piston type specified) are recommended.

*Hi-Load Piston design available only in 1 1/2", 2" and 2 1/2" bores with oversize rod.

Thrust Key Mounting

In addition to mounting bolts, Style F cylinders should be keyed to the mounting surface with a thrust key.

An optional groove can be supplied in the head for installing a thrust key.

Bore	+0.001 -0.000		
	FA	PA	TA
1 1/2	0.312	5/32	5/8
2	0.375	3/16	3/4
2 1/2	0.375	3/16	3/4
3 1/4	0.500	1/4	7/8
4	0.500	1/4	7/8

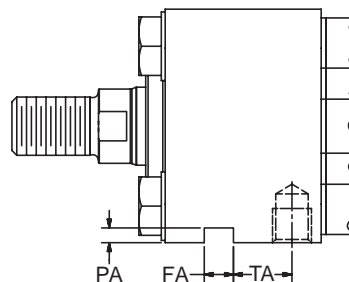

Parts Identification

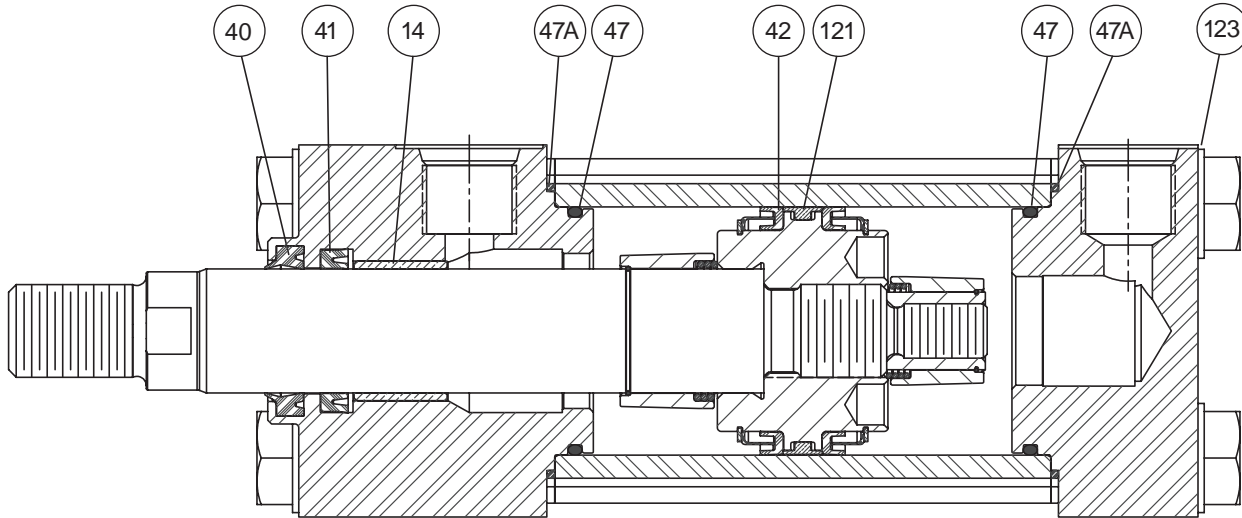

Parts List

Symbol	Description
14	Rod bearing
40	Rod wiper
41	Rod Seal
42	Lipseal, piston
47	O-ring, cylinder body to head and cap seal

Symbol	Description
47A	Gasket, cylinder body to head and cap seal
119	Outer Ring
120	Inner Ring
121	Wear ring
123	Washer

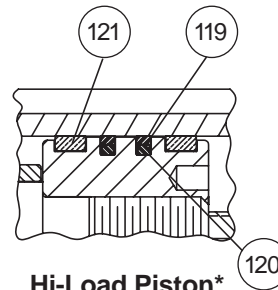

*Hi-Load Piston design available only in 1 1/2", 2" and 2 1/2" bores with oversize rod.

Seal Kits

See Model Code and Standard Specifications page for compatibility.

Piston Seal Kits

Bore Ø	Rod Ø	Class 1		Class 5	
		Piston Lipseal Kits (contains: 2 Each Sym. # 42, 47 & 47A)	Hi-Load Piston Seal Kits (contains: 2 Each Sym. # 119, 120, 121, 47 & 47A)	Piston Lipseal Kits (contains: 2 Each Sym. # 42, 47 & 47A)	Hi-Load Piston Seal Kits (contains: 2 Each Sym. # 119, 120, 121, 47 & 47A)
1 1/2	5/8	PK15SHG001	N/A	PK15SHG005	N/A
	1	N/A	PK15SHGK01	N/A	PK15SHGK05
2	1	PK20SHG001	N/A	PK20SHG005	N/A
	1 3/8	N/A	PK20SHGK01	N/A	PK20SHGK05
2 1/2	1	PK25SHG001	N/A	PK25SHG005	N/A
	1 3/4	N/A	PK25SHGK01	N/A	PK25SHGK05
3 1/4	All	PK32SHG001	N/A	PK32SHG005	N/A
4	All	PK40SHG001	N/A	PK40SHG005	N/A

Note: Lipseal piston design is not available in 1 1/2", 2", and 2 1/2" bores with oversize rod. Use Hi-Load piston seal kit to service these bore and rod combinations.

Rod Bearing and Seal Kits

Bore Ø	Rod Ø	Class 1	Class 5
		Rod Bearing & Seal Kits (contains: 1 Each Sym. # 14, 40, 41, 47 & 47A)	Rod Bearing & Seal Kits (contains: 1 Each Sym. # 14, 40, 41, 47 & 47A)
1 1/2	5/8	RGSHG15061	RGSHG15065
	1	RGSHG15101	RGSHG15105
2	1	RGSHG20101	RGSHG20105
	1 3/8	RGSHG20131	RGSHG20135
2 1/2	1	RGSHG25101	RGSHG25105
	1 3/4	RGSHG25171	RGSHG25175
3 1/4	1 3/8	RGSHG32131	RGSHG32135
	2	RGSHG32201	RGSHG32205
4	1 3/4	RGSHG40171	RGSHG40175
	2 1/2	RGSHG40251	RGSHG40255

Stat-O-Seal™ Washer Kit
for Series SHG†

Bore Ø	Stat-O-Seal Washer Kit (contains: 8 Each Sym. # 123)	Head & Cap Bolt Torque†† (ft. lbs.)
1 1/2	WK15SHG001	18 - 19
2, 2 1/2	WK25SHG001	46 - 49
3 1/4	WK40SHG001	120 - 124
4	WK40SHG001	131 - 135

† Stat-O-Seal washers must be replaced when reassembling a Series SHG cylinder.

†† Anti-seize lubricant required on bolt thread.

H-1 rated anti-seize lubricant must be used for Series SHG.

Hydraulic and Pneumatic Cylinder Appendix Application Engineering Data

Operating Principles and Construction	Pages 50-51
Theoretical Push and Pull Forces for Hydraulic and Pneumatic Cylinders	Pages 52, 93
Fluid Service – Industrial Cylinders	
Operating Fluids and Temperature Range	
Water Service	
Warranty	
Pre-Lubricated/Non-Lubricated Air Cylinders	Pages 54-55
Pressure Ratings	
PA-2, PN, PH-2, PL-2 Series Cylinders	Page 56
SHM Series Cylinders	Page 98
Mounting Information	
PA-2, PH-2, PL-2 Series Cylinders	Pages 57-60
SHM Series Cylinders	Pages 91-92
Straight Line Force Transfer (Group 1)	Page 57
Straight Line Force Transfer (Group 3)	Page 58
Pivot Force Transfer (Group 2)	Page 59
Accessories	Page 60
Port Data	
Straight Thread and International Ports	Pages 61-62
Oversize NPTF, S.A.E. Ports and Manifold Ports	Pages 63-64
SHM Series Cylinders	Pages 99-100
Rod End Data	
Rod End Style 3 Minimum Stroke for PH-2 and PH-3 Series	Page 53
Piston Rod End Threads, International Rod End Threads, Special Rod Ends, Special Assemblies, Single Acting Cylinders	Page 65
Stroke Data – Tie Rod Supports – Gland Drain	
Stroke Adjusters, Thrust Key Mountings, Gland Drain	Pages 66-67
Acceleration and Deceleration Data	
PA-2, PL-2, PH-2, PH-3 Series Cylinders	
SHM Series Cylinders	Page 77
Stop Tubing – Mounting Classes	
PH-3 Series Cylinders	
SHM Series Cylinders	Page 68
Cylinder Stroke Selection Chart – Mounting Groups	Pages 69, 94-95
Cushioning	
PH-2 and 7" & 8" Bore PH-3	Pages 70-75
SHM Series	Pages 96-98
Hydraulic Cylinder Port Sizes and Piston Speed	Pages 78-79
Deceleration Force and Air Requirements for Air Cylinders	Page 80
Air Cylinder Cushion Ratings – Air Requirements	Pages 81-83
Modifications	
Metallic Rod Wiper, Air Bleeds, Rod End Boots, Tandem Cylinders, Duplex Cylinders	Page 84
Cylinder Weights	
PA-2, PN, PH-2, PL-2 Series Cylinders	Page 85
SHM Series	Page 100
Large Bore PH-3 Series Technical Data	Pages 86-90
SHM Series Technical Data	Pages 91-102
Cylinder Safety Guide	Pages 104-105

Cylinder Operation

Cylinders are used in the majority of applications to convert fluid energy into straight line motion. For this reason, they are often called linear actuators.

Cylinders are manufactured in a variety of diameters, stroke lengths, and mounting styles. They may be classified, according to construction, into four types: tie-rod, threaded, welded, and flanged. Cylinders are also made using retaining rings.

$$\text{Area} = \frac{\pi D^2}{4} \text{ or } \text{Area} = .7854 \times D^2$$

When calculating force developed on the return stroke, pressure does not act on the rod area of the piston, therefore the rod area must be subtracted from the total piston area.

Basic Construction

The major components of a cylinder are the head, cap, tube tie rods, piston, piston rod, rod bearing and seals.

Cylinder Heads and Caps are usually made from rolled steel or cast iron. Some are also from aluminum or bronze.

Cylinder Tubes are usually brass, steel or aluminum. The inside, and sometimes the outside, is plated or anodized to improve wear characteristics and reduce corrosion.

Illustration B-28

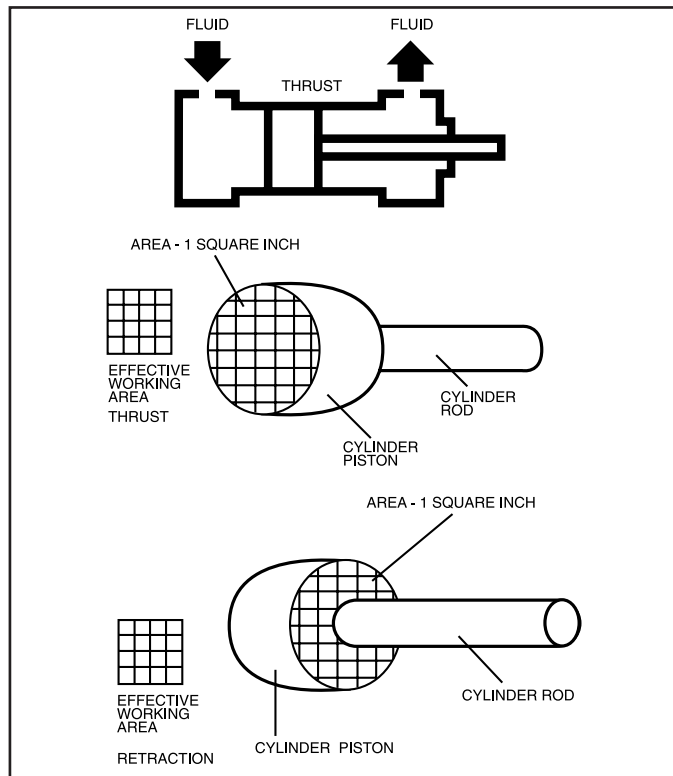

Pistons vary in design and materials used. Most are made of cast iron, steel or aluminum. Several methods of attaching the piston to the rod are used. Cushions, are an available option on most cylinders and most often, can be added with no change in envelope dimensions.

Piston Rods are generally high strength steel, case-hardened, ground, polished and hard chrome plated for wear and corrosion resistance. Corrosive atmosphere conditions usually require rods of stainless steel, which may be chrome plated for wear resistance.

Rod Glands or Bearings are used on the head end of most industrial cylinders to support the piston rod as it travels back and forth. The gland also acts as a retainer for the rod packing and seals. Most are made of ductile iron or bronze and usually are removable without disassembling the entire cylinder.

The gland usually contains a piston rod wiper or scraper on the outboard side to remove dirt and contamination from the rod, and prevent foreign material from being drawn into the packings. A primary seal is used to seal the cylinder pressure.

Seals are generally made from Nitrile or fluorocarbon elastomers, polyurethane, leather or P.T.F.E. The Lipseal™ shape is commonly used for both piston and piston rod seals. Generally, O-Rings are used for static applications such as head to tube, piston to rod, and head to gland. Cup or V-packings are used for sealing piston and piston rod. Piston rings are usually cast iron.

Tie-Rods are usually high tensile steel with either cut or rolled threads, prestressed during assembly. Prestressing with proper torque prevents separation of parts when subjected to pressure and reduces the need for locknuts, although locknuts are sometimes used.

Fundamental Cylinders

Standard Double-Acting Cylinders

Power stroke is in both directions and is used in the majority of applications.

Single-Acting Cylinders

When thrust is needed in only one direction, a single-acting cylinder may be used. The inactive end is vented to atmosphere through a breather/filter for pneumatic applications, or vented to reservoir below the oil level in hydraulic application.

Double-Rod Cylinders

Used when equal displacement is needed on both sides of the piston, or when it is mechanically advantageous to couple a load to each end. The extra end can be used to mount cams for operating limit switches, etc.

Spring Return, Single-Acting Cylinders

Usually limited to very small, short stroke cylinders used for holding and clamping. The length needed to contain the return spring makes them undesirable when a long stroke is needed.

Ram Type, Single-Acting Cylinders

Containing only one fluid chamber, this type of cylinder is usually mounted vertically. The weight of the load retracts the cylinder. They are sometimes know as "displacement cylinders", and are practical for long strokes.

Telescoping Cylinders

Available with up to 4 or 5 sleeves; collapsed length is shorter than standard cylinders. Available either single or double-acting, they are relatively expensive compared to standard cylinders.

Tandem Cylinders

A tandem cylinder is made up of two cylinders mounted in line with pistons connected by a common piston rod and rod seals installed between the cylinders to permit double acting operation of each. Tandem cylinders allow increased output force when mounting width or height are restricted.

Duplex Cylinders

A duplex cylinder is made up of two cylinders mounted in line with pistons not connected and with rod seals installed between the cylinders to permit double acting operation of each. Cylinders may be mounted with piston rod to piston (as shown) or back to back and are generally used to provide three position operation.

Illustration B29

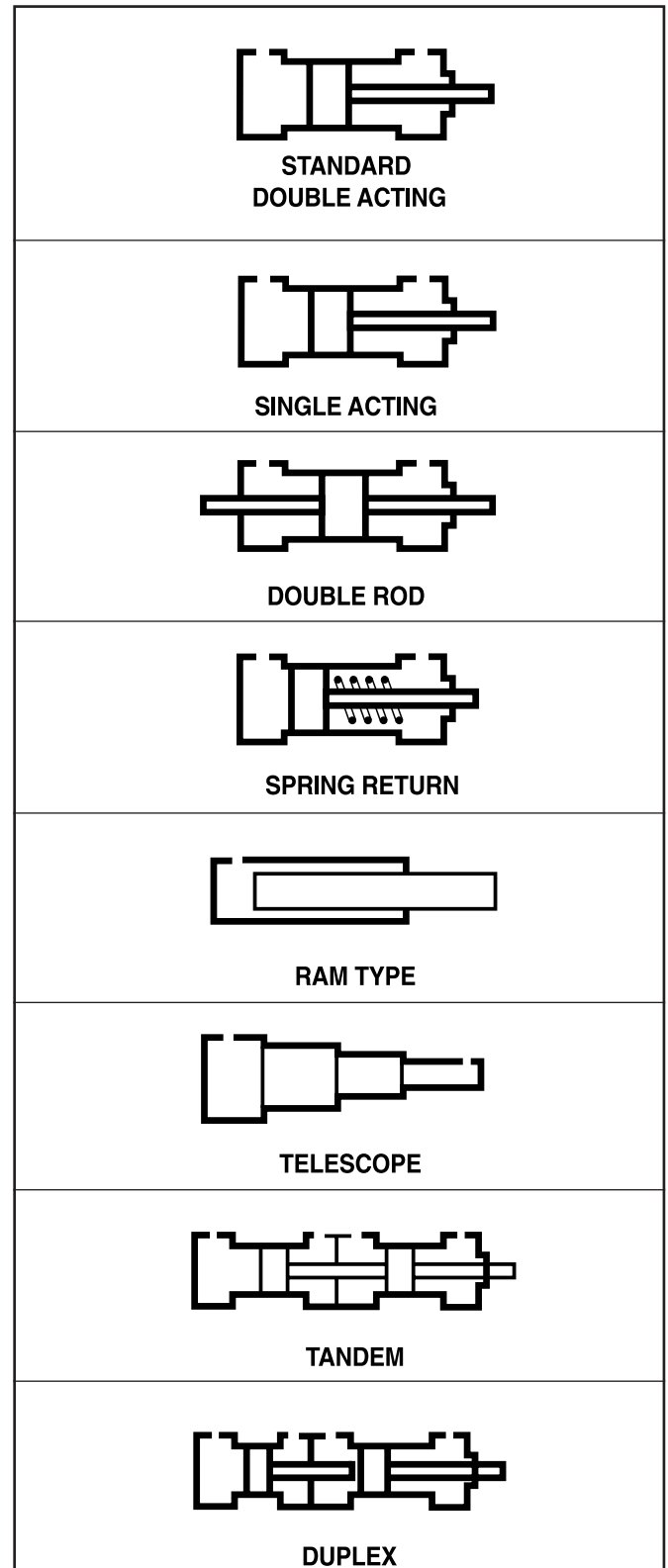

C

Theoretical Push and Pull Forces for Pneumatic and Hydraulic Cylinders

Push Force and Displacement

Cyl. Bore Size (Inches)	Piston Area (Sq. In.)	Cylinder Push Stroke Force In Pounds At Various Pressures										Cu. Ft. Free Air At 80 Lbs. Pressure, Required To Move Max. Load 1 Inch	Displacement Per Inch Of Stroke (Gallons)
		25	50	65	80	100	250	500	1000	2000	3000		
1	.785	20	39	51	65	79	196	392	785	1570	2355	.00293	.00340
1½	1.767	44	88	115	142	177	443	885	1770	3540	5310	.00659	.00765
2	3.14	79	157	204	251	314	785	1570	3140	6280	9420	.01171	.0136
2½	4.91	123	245	319	393	491	1228	2455	4910	9820	14730	.01830	.0213
3¼	8.30	208	415	540	664	830	2075	4150	8300	16600	24900	.03093	.0359
4	12.57	314	628	817	1006	1257	3143	6285	12570	25140	37710	.04685	.0544
5	19.64	491	982	1277	1571	1964	4910	9820	19640	39280	58920	.07320	.0850
6	28.27	707	1414	1838	2262	2827	7068	14135	28270	56540	84810	.10541	.1224
7	38.49	962	1924	2502	3079	3849	9623	19245	38490	76980	115470	.14347	.1666
8	50.27	1257	2513	3268	4022	5027	12568	25135	50270	100540	150810	.18740	.2176
10	78.54	1964	3927	5105	6283	7854	19635	39270	78540	157080	235620	.29280	.3400
12	113.10	2828	5655	7352	9048	11310	28275	56550	113100	226200	339300	.42164	.4896
14	153.94	3849	7697	10006	12315	15394	38485	76970	153940	307880	461820	.57389	.6664

Deductions for Pull Force and Displacement

Piston Rod Dia. (Inches)	Piston Area (Sq. In.)	Piston Rod Diameter Force In Pounds At Various Pressures										Cu. Ft. Free Air At 80 Lbs. Pressure, Required To Move Max. Load 1 Inch	Displacement Per Inch Of Stroke (Gallons)
		To determine Cylinder Pull Force or Displacement, deduct the following Force or Displacement corresponding to Rod Size, from selected Push Stroke Force or Displacement corresponding to Bore Size in table above.											
		25	50	65	80	100	250	500	1000	2000	3000		
½	.196	5	10	13	16	20	49	98	196	392	588	.00073	.0009
5/8	.307	8	15	20	25	31	77	154	307	614	921	.00114	.0013
1	.785	20	39	51	65	79	196	392	785	1570	2355	.00293	.0034
1⅜	1.49	37	75	97	119	149	373	745	1490	2980	4470	.00554	.0065
1¾	2.41	60	121	157	193	241	603	1205	2410	4820	7230	.00897	.0104
2	3.14	79	157	204	251	314	785	1570	3140	6280	9420	.01171	.0136
2½	4.91	123	245	319	393	491	1228	2455	4910	9820	14730	.01830	.0213
3	7.07	177	354	460	566	707	1767	3535	7070	14140	21210	.02635	.0306
3½	9.62	241	481	625	770	962	2405	4810	9620	19240	28860	.03587	.0416
4	12.57	314	628	817	1006	1257	3143	6285	12570	25140	37710	.04685	.0544
4½	15.90	398	795	1033	1272	1590	3975	7950	15900	31800	47708	.05929	.0688
5	19.64	491	982	1277	1571	1964	4910	9820	19640	39280	58920	.07320	.0850
5½	23.76	594	1188	1544	1901	2376	5940	11880	23760	47520	71280	.08857	.1028
7	38.49	962	1924	2502	3079	3849	9623	19245	38490	76980	115470	.14347	.1666
8½	56.75	1419	2838	3689	4540	5675	14187	28375	56750	113500	170250	.21157	.2455

General Formula

The cylinder output forces are derived from the formula:

$$F = P \times A$$

Where F = Force in pounds.
 P = Pressure at the cylinder in pounds per square inch, gauge.
 A = Effective area of cylinder piston in square inches.

Free Air refers to normal atmospheric conditions of the air at sea level (14.7 psi). Use above cu. ft. free air required data to compute CFM required from a compressor at 80 psi. Cu. ft. of free air required at other pressures can be calculated using formula below.

$$V_1 = \frac{(P_2 + 14.7) V_2}{14.7}$$

Where V₁ = Free air consumption per inch of stroke (cubic feet).

V₂ = Cubic feet displaced per inch of stroke.

P₂ = Gauge pressure required to move maximum load.

**PH-2 & PH-3 Series, Rod End Style 3
Minimum Stroke**

Sufficient clearance must exist between machining for female rod end style 3 and the threaded piston-to-rod connection. This clearance is required to maintain pressure envelope integrity and envelope ratings shown above.

To maintain the required clearance, a minimum stroke is required for some bore and rod combinations. See the table below for minimum stroke requirements. Contact the factory when a style 3 rod end with a stroke shorter than shown in the table is required.

Bore	Rod Dia.	Minimum Stroke
1.50 - 4.00	All	None
5.00	2.000	None
	2.500	1.00
	3.000	1.38
	3.500	1.63
6.00	2.500	None
	3.000	1.38
	3.500	1.38
7.00	4.000	2.00
	3.000	1.25
	3.500	1.50
8.00	4.000	1.50
	5.000	3.13
	3.500	1.50
	5.500	3.63

Bore	Rod Dia.	Minimum Stroke
10.00	4.500	1.13
	5.000	1.38
	5.500	2.00
	7.000	3.13
12.00	5.500	1.25
	7.000	2.38
	8.000	1.13
14.00	7.000	2.00
	8.000	2.75
	10.000	4.25
16.00	8.000	1.75
	9.000	2.50
	10.000	3.25
18.00	9.000	1.50
	10.000	2.25
20.00	10.000	1.25

Operating Fluids and Temperature Range

Cylinders are designed for use with pressurized air, hydraulic oil and fire resistant fluids, in some cases special seals are required.

Standard Seals (Class 1)

Standard seals are what is normally provided in a cylinder unless otherwise specified. They are intended for use with fluids such as: air, nitrogen, mineral base hydraulic oil or MIL-H-5606 within the temperature range of -10°F (-23°C) to +165°F (+74°C). Generally they are nitrile except for piston rod seals in hydraulic cylinders. However the individual seals may be nitrile (Buna-N) enhanced polyurethane, polymyte, P.T.F.E. or filled P.T.F.E.

Water Base Fluid Seals (Class 2)

Generally these seals are intended for use with water base fluids within the temperature of -10°F (-23°C) to +165°F (+74°C) except for High Water Content Fluids (H.W.C.F.) in which case H.W.C.F. seals should be used. Typical water base fluids are: Water, Water-Glycol, Water-in Emulsion, Houghto-Safe 27, 620, 5040, Mobil Pyrogard D, Shell Iruis 905, Ucon Hydrolube J-4. These seals are nitrile. Lipseal will have polymyte or P.T.F.E. back-up washer when required. O-rings will have nitrile back-up washers when required.

Ethylene Propylene (E.P.R.) Seals (Class 3)

These seals are intended for use with some Phosphate Ester Fluids between the temperatures of -10°F (-23°C) to +130°F (+54°C). Typical fluids compatible with E.P.R. seals are Skydrol 500 and 700. E.P.R. are Ethylene Propylene. Lipseals will have a P.T.F.E. back-up washer when required. O-rings will have EPR back-up washers when required. **Note:** E.P.R. seals are not compatible with mineral base hydraulic oil or greases. Even limited exposure to these fluids will cause severe swelling. P.T.F.E. back-up washer may not be suitable when used in a radiation environment.

Low Temperature Nitrile Seals (Class 4)

Low temperature nitrile seals are intended for low temperature service with the same type of fluids as used with standard seals within the temperature range of -50°F (-46°C) to +150°F (+66°C). Lipseals will have leather, polymyte or P.T.F.E. back-up washers when required. O-rings will have nitrile back-up washers when required.

Fluorocarbon Seals (Class 5)

Fluorocarbon seals are intended for elevated temperature service or for some Phosphate Ester Fluids such as Houghto-Safe 1010, 1055, 1120; Fyrquel 150, 220, 300, 350; Mobile Pyrogard 42, 43, 53, and 55. **Note:** In addition, fluorocarbon seals can be used with fluids listed below under standard service. However, they are not compatible with Phosphate Ester Fluids such as Skydrols. Fluorocarbon seals can operate with a temperature range of -10°F (-23°C) to +250°F (+121°C). Fluorocarbon seals may be operated to +400°F (+204°C) with limited service life. For temperatures above +250°F (+120°C) the cylinder must be manufactured with non-studded piston rod and thread and a pinned piston to rod connection. Fluorocarbon Lipseals will have P.T.F.E. back-up washers when required. O-rings will have fluorocarbon back-up when required.

⚠ Warning

The piston rod stud and the piston rod to piston threaded connections are secured with an anaerobic adhesive which is temperature sensitive. Cylinders specified with fluorocarbon seals are assembled with anaerobic adhesive having a maximum temperature rating of +250°F (+74°C). Cylinders specified with all other seal compounds are assembled with anaerobic adhesive having a maximum operating temperature rating +165°F (+74°C). These temperature limitations are necessary to prevent the possible loosening of the threaded connections. Cylinders originally manufactured with standard seals (Nitrile) that will be exposed to ambient temperatures above +165°F (+74°C) must be modified for higher temperature service. Contact the factory immediately and arrange for the piston to rod and the stud to piston rod connections to be properly re-assembled to withstand the higher temperature service.

H.W.C.F. Seals (Class 6)

These seals are intended for High Water Content Fluids (H.W.C.F.) such as Houghton Hydrolubric 120B and Sonsol Lubrizol within the temperature range of +40°F (+4°C) to +120°F (+49°C). H.W.C.F. seals are special nitrile compound dynamic seals. Lipseals will have P.T.F.E. and or polymyte back-up washers when required. O-rings will have nitrile back-up washers when required. Because of the viscosity of these fluids, cylinders specified with H.W.C.F. seals, will also be modified to have lip seal piston seals and straight cushions.

Spring Loaded PTFE Seals (Class 8 Seals)

Class 8 seals consist of PTFE piston lipseals, rod lipseal and wiper lipseal, each with an internal stainless steel spring to energize both the static and dynamic sealing lips. They are intended for high temperature applications, to 400° F (204° C), where longer seal life and improved high temperature sealing performance is required. Body and gland o-ring seals will be fluorocarbon. Fluid resistance is comparable to Class 5.

Hi-Load Seals

Hi-load seals consist of one or two filled P.T.F.E. dynamic piston seals with an elastomer expander underneath. Hi-load piston arrangement normally consists of a wear ring on each end of the piston with the seals in the middle. These types of seals are virtually leak free seals under static conditions and can tolerate high pressure. The wear rings on the piston can also tolerate high side loads. The dynamic portion of the seal is bronze filled P.T.F.E. and compatible with all conditions and fluids listed on this page. However, carbon filled P.T.F.E. will provide better seal life when used with H.W.C.F. fluids. A nitrile expander will be provided unless EPR or fluorocarbon seals are specified. In those cases the expander will be of E.P.R. or fluorocarbon respectively. **Note:** It may be necessary to cycle the piston seals 40 or 50 times before achieving leakage free performance.

Lipseal Pistons

Under most conditions lipseals provide the best all around service for pneumatic applications. Lipseals with a back-up washer are often used for hydraulic applications when virtually zero static leakage is required. Lipseals will function properly in these applications when used in conjunction with moderate hydraulic pressures. A high load piston option is recommended when operating at high pressures and especially with large bore hydraulic cylinders.

Low Friction Hydraulic Seals

Low Friction hydraulic seals are available as an option for both piston and rod seals for PH-2, PH-3 and PL-2 Series cylinders. They are sometimes used when a cylinder is controlled by servo or proportional valve. The seal assembly itself is a two piece assembly consisting of a filled P.T.F.E. dynamic seal with an elastomer expander. A piston seal assembly consists of one seal assembly in the middle of the piston with a filled P.T.F.E. wear ring on each side of the piston. The piston rod seal assembly consists of two seal assembled and an elastomer wiper seal. The filled P.T.F.E. seals are compatible with the fluids listed on this page and provide virtually leak free sealing. The expanders and rod wiper will be nitrile unless E.P.R. or fluorocarbon seals are specified. In those cases the expanders and wiper will be E.P.R. and fluorocarbon respectively. When specifying low friction seals specify if piston, piston rod seals or both are required. **Note:** It may be necessary to cycle these seals 40 or 50 times before achieving leakage free performance.

Cast Iron Piston Rings

Cast iron rings are the standard piston seals for PH-2 and PL-2 Series cylinders. They offer the widest operating conditions by tolerating high operating pressures, wide temperature range and are compatible with most fluids. The only drawback of cast iron rings is that they allow a small amount of leakage. The leakage for a 4" bore cylinder, operating at 2000 psi, with mineral base hydraulic fluid will be less than 10in³/min. Leakage will increase as pressure, bore size and viscosity of the operating hydraulic fluid increases. For these reasons cast iron rings are not recommended when using water or (H.W.C.F.) fluids.

Water Service

For pressures up to 250 psi PA-2 and PL-2 series cylinders can be modified to make them more suitable for use with water as the operating medium. The modifications include chrome-plated cylinder bore; cadmium-plated head, cap and piston; chrome-plated 17-4 stainless steel piston rod; chrome plated cushion sleeve or cushion spear.

Modified cylinders may also be used for higher operating pressures, up to 2000 psi, depending on bore size. See pressure rating for Hydraulic Cylinders. PL-2, PH-2 and PH-3 Series hydraulic cylinders can also be modified for water operation and supplied with chrome-plated cylinder bore; cadmium-plated head, cap and piston; chrome-plated precipitation hardened stainless steel piston rod, chrome-plated cushion sleeve or cushion spear. When high water base fluids are the operating medium, hydraulic cylinders are usually supplied with high water base rod wiper and seals. Water and high water base fluid operated cylinders are best used on short stroke applications or where high pressure is applied only to clamp the load.

Warranty

Schrader Bellows will warrant cylinders modified for water or high water content fluid service to be free of defects in materials or workmanship, but cannot accept responsibility to premature failure due to excessive wear due to lack of lubricity or where failure is caused by corrosion, electrolysis or mineral deposits within the cylinder.

Pre-Lubricated Air Cylinders

Schrader Bellows air cylinders are factory pre-lubricated with Lube-A-Cyl applied to seals, piston, cylinder bore, piston rod and gland surfaces, provides for normal cylinder operations with lubricated air.

Non-Lubricated Air Cylinders

For heavier duty operation, Series PN is recommended for non-lubricated air service. Series PN includes an innovative special composite material wick and ring reservoir assembly in each seal groove to retain the extreme pressure lubricant applied at time of assembly. This lubricant coats the cylinder bore and piston rod and mating surfaces.

Class No.	Typical Fluids	Temperature Range
1 (Standard) (Nitrile Polyurethane)	Air, Nitrogen Hydraulic Oil, Mil-H-5606 Oil	-10°F (-23°C) to +165°F (+74°C)
2 Optional Water Base Fluid Seal	Water, Water-Glycol, H.W.C.F. — See Class 6 below. Water-in-Oil Emulsion Houghto-Safe, 271, 620, 5040 Mobil Pyrogard D, Shell IruS 905 Ucon Hydrolube J-4	-10°F (-23°C) to +165°F (+74°C)
3 Special (E.P.R.) (At extra cost)	Some Phosphate Ester Fluids Skydrol 500, 7000	-10°F (-23°C) to +130°F (+54°C)
Note: (E.P.R.) seals are not compatible with Hydraulic Oil		
4 Special (Nitrile) (At extra cost)	Low Temperature Air or Hydraulic Oil	-50°F (-46°C) to +150°F (+66°C)
5 Optional (At extra cost) (Fluorocarbon Seals)	High Temperature Houghto-Safe 1010, 1055, 1120 Fyrquel 150, 220, 300, 550 Mobil Pyrogard 42,43,53,55	See paragraph on previous page for recommended temperature range of fluorocarbon seals.
Note: Fluorocarbon seals are not suitable for use with Skydrol fluid, but can be used with hydraulic oil if desired		
6 Optional (HWCF) (At extra cost)	Houghton, Hydrolubric 120B Sonsol Lubrizol, for other HWCF — consult factory.	+40°F (+4°C) to +120°F (+49°C)
8 Optional (At extra cost) Spring Loaded PTFE	See Class 5 Seals	-15°F (-26°C) to 400°F (204°C)

Application Data

The proper application of a fluid power cylinder requires consideration of the operating pressure, the fluid medium, the mounting style, the length of stroke, the type of piston rod connection to the load, thrust or tension loading on the rod,

mounting attitude, the speed of stroke, and how the load in motion will be stopped. Information given here provides pressure rating data for pneumatic and hydraulic cylinders.

Pneumatic Cylinders

Standard operating fluid — filtered air which is free of moisture. PA-2 and PN Series cylinders are recommended for maximum 250 psi heavy duty service.

Pressure Ratings Fluid Medium Air

Bore Size (Inches)	Standard Piston Rod Diameters (Inches)	Series PA-2, PN Max. Heavy-Duty Operating Pressure (PSI)
1	1/2	250
1 1/2	5/8	250
2	5/8	250
2 1/2	5/8	250
3 1/4	1	250
4	1	250
5	1	250
6	1 3/8	250
8	1 3/8	250
10	1 3/4	250
12	2	250
14	2 1/2	250

Hydraulic Cylinders (Heavy duty)

Standard operating fluid – clean, filtered hydraulic oil. Pressure ratings for heavy duty hydraulic cylinders are shown in the following table:

Pressure Ratings

PH-2 and PH-3 Series (7" & 8") hydraulic cylinders are recommended for pressures to 3000 p.s.i. for heavy-duty service with hydraulic oil. The 4:1 design factor ratings shown are based on tensile strength of material and are for code 1 rod dia. only. The rating is conservative for continuous severe applications. Design factors at other pressures can be calculated from this rating. In addition, mounting styles, stroke, etc., should be considered because of the limiting effect they may have on these ratings.

Maximum Pressure Ratings

Bore Size (Inches)	Rod Diameter (Inches)	4:1* Design Factor (Tensile) (PSI)	Heavy-Duty Service (PSI)
1 1/2	5/8	2530	3000
2	1	2950	3000
2 1/2	1	2340	3000
3 1/4	1 3/8	2250	3000
4	1 3/4	2130	3000
5	2	2170	3000
6	2 1/2	2270	3000
7	3	2030	3000
8	3 1/2	2040	3000

*Applies to all mountings except MF1 and MP2.

Hydraulic Cylinders (Medium duty)

Pressure ratings for PL-2 Series hydraulic cylinders vary by bore size and rod size as shown in table below. For pressures higher than those indicated, PH-2 Series heavy duty cylinders should be used.

PL-2 Series Hydraulic Cylinders Maximum Pressure Rating

Bore Size	Rod Diameters	Pressure Rating At 4:1 Design* Factor (On Tensile)
1	1/2	1900
	5/8	1900
1 1/2	5/8	2000
	1	2300
2	5/8	1100
	1	2000
	1 3/8	2000
2 1/2	5/8	700
	1	1400
	1 3/8	1400
	1 3/4	1400
3 1/4	1	1300
	1 3/8	1300
	1 3/4	1300
	2	1300
4	1	900
	1 3/8	900
	1 3/4	900
	2	900
	2 1/2	900
5	1	600
	1 3/8	950
	1 3/4	950
	2	950
	2 1/2	950
	3	950
6	3 1/2	950
	1 3/8	700
	1 3/4	700
	2	700
	2 1/2	700
	3	700
	3 1/2	700
4	700	
8	1 3/8	400
	1 3/4	650
	2	650
	2 1/2	650
	3	650
	3 1/2	650
	4	650
	4 1/2	650
	5	650
5 1/2	650	

*Applies to all mountings except MF1.

Single rod type, fluid power cylinders are commonly available in 16 standard mounting styles ranging from head or cap end mounts to intermediate mounts. Many mounting styles are also available in double rod type cylinders. Refer to ANSI/(NFPA) T3.6.7R2-1996 Specifications and Mounting Dimension Standards or Schrader Bellows air or hydraulic cylinder catalogs for detailed description.

Standard mounting styles for fluid power cylinders fall into three basic groups. The groups can be described as follows.

Group 1 – Straight line force transfer with fixed mounts which absorb force on cylinder centerline.

Group 3 – Straight line force transfer with fixed mounts which do not absorb force on cylinder centerline.

Group 2 – Pivot force transfer with pivot mounts which absorb force on cylinder centerline and permit cylinder to change alignment in one plane.

Cylinder mounting directly affects the maximum pressure at which the fluid power cylinder can be used, and proper selection of mounting style will have a bearing on cylinder operation and service life. Whether the cylinder is used in thrust or tension, its stroke length, piston rod diameter and the method of connection to load also must be considered when selecting a mounting style.

Cylinders are offered for use with air pressure up to 250 psi; medium-duty hydraulic, depending on bore size, up to 2200 psi; and heavy-duty hydraulic service of up to 3000 psi. The industrial tie rod types, known as NFPA cylinders, with square steel heads and caps, plus steel mountings lend themselves to standardized mounts which are similar in appearance for both air and hydraulic cylinders.

Because of the all steel construction, Schrader Bellows air cylinders have a design factor of better than 4:1, and the various mounts can be used without limitations up to the cylinder manufacturer's maximum rated pressure. Medium-duty and heavy-duty hydraulic cylinders, in some mounting styles, may not be used at full rated pressure, depending on mounting style, stroke length and thrust or tension loading, as discussed in the following:

Straight Line Force Transfer (Group 1)

Cylinders with fixed mounts (Group 1) which absorb the force on centerline are considered the best for straight line force transfer. Tie rods extended, flange or centerline lug mounts are symmetrical and allow the thrust or tension forces of the piston rod to be distributed uniformly about the cylinder centerline. Mounting bolts are subjected to simple tension or simple shear without compound forces, and when properly installed damaging cylinder bearing sideloads is kept to a minimum.

Tie Rods Extended are considered to be of the centerline mount type. The cylinder tie rods are designed to withstand maximum rated internal pressure and can be extended and used to mount the cylinder at cap or head end. This often overlooked mounting will securely support the cylinder when bolted to the panel or machine member to which the cylinder is mounted. The torque value for the mounting nuts should be the same as the tie rod nut torque recommended by the cylinder manufacturer. Cylinders are available with tie rod extended both ends. In such applications one end is used for mounting and the opposite end to support the cylinder or to attach other machine components.

Tie rod mount cylinders may be used to provide thrust or tension forces at full rated pressures.

Tie rods extended head end (Style MX3), cap end (Style MX2) or extended both ends (Style MX1) are readily available and fully dimensioned in Schrader Bellows cylinder product catalogs.

Flange Mount cylinders are also considered to be centerline mount type and thus are among the best mounts for use on straight line force transfer applications. The machine designer has a choice of three mounting styles at each end, such as head rectangular flange (Style MF1), head square flange (Style MF5), head rectangular (Style ME5), cap rectangular flange (Style MF2), cap square flange (Style MF6), and cap rectangular (Style ME6). Selection of a flange mounting style depends, in part, upon whether the major force applied to the load will result in compression (push) or tension (pull) stresses of the cylinder piston rod. Cap end mounting styles are recommended for thrust loads (push), while head end mounting styles are recommended where the major load puts the piston rod in tension (pull).

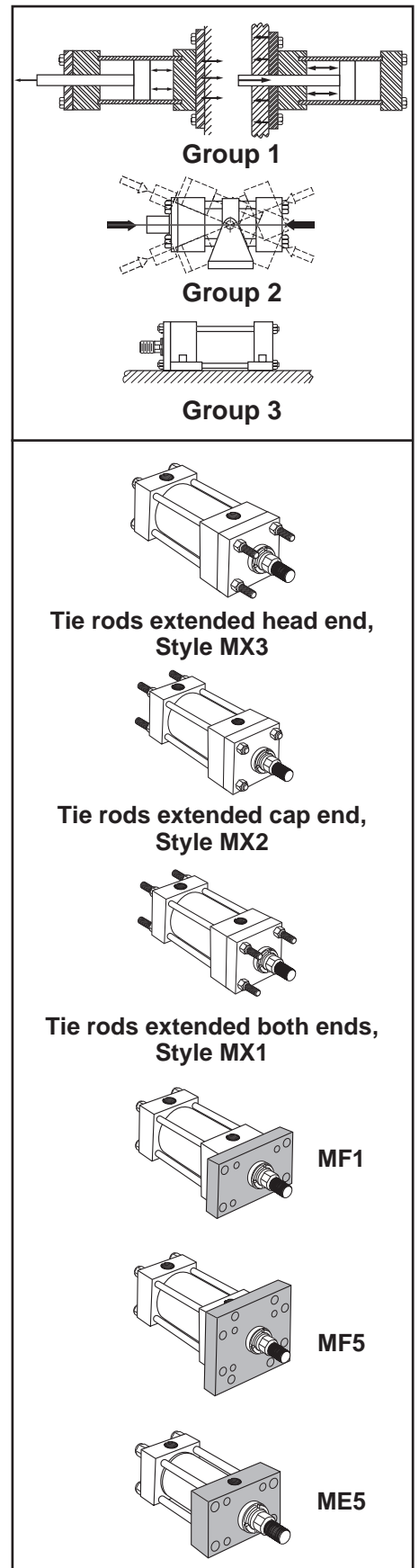

Flange mounts are best used when end face is mounted against the machine support member. (Fig. 1) This is especially true where head rectangular flange type (Style MF1) is used with major load in tension. In this mode, the flange is not subjected to flexure or bending stresses, nor are the mounting bolts stressed to unusually high levels. The use of head rectangular flange (Style MF1) mount with major load in compression (see Fig. 2) is not recommended except on reduced pressure systems. The use of Style MF1 mount in compression subjects the flange to bending and the mounting bolts to tension stresses, which could result in early fatigue failure. For maximum allowable pressure with Style MF1 head rectangular mount used for compression (push) or rear face of flange mounted, see pressure rating in product catalogs for medium- or heavy-duty hydraulic cylinders. For applications where push forces require full rated system pressure, head square flange (Style MF5) or head rectangular (Style ME5) mounts are recommended. The best head style mounting for either push or pull applications at full rated pressure is Style ME5.

Style ME5 mount has the same mounting hole pattern and rectangular dimensions as the Style MF1 mount. To substitute the head rectangular Style ME5 mount for the head rectangular flange, Style MF1 mount, it is necessary to use spacers to fill in the cataloged "F" dimension previously occupied by the "MF1" flange. The spacers are installed as shown in Fig. 3.

Cap flange mounts are also best used when end face is mounted against the machine support member. The use of cap rectangular flange mount, Style MF2, is not recommended on applications where the major load is in tension (pull) except at reduced pressure. For maximum allowable pressure with cap rectangular flange, Style MF2, used in tension application (pull) or front of flange mounted, see maximum pressure rating in product catalogs for medium- and heavy-duty hydraulic cylinders.

For applications where pull forces involved require full rated system pressure, cap square flange, Style MF6, or cap rectangular, Style ME6, mounts are recommended. The best cap style mounting for either push or pull applications at full rated pressure is the cap rectangular Style ME6.

The Style ME6 mount has the same mounting hole pattern and rectangular dimensions as the Style MF2 mount. To substitute the Style ME6 for Style MF2, it is necessary to use spacers or order a cylinder with piston rod extension to make up for the cataloged "F" dimension previously occupied by the "MF2" flange.

Straight Line Force Transfer (Group 3)

Side Mount cylinders are considered to be fixed mounts which do not absorb force on their centerline. Cylinders of this group have mounting lugs connected to the ends, and one style has side tapped holes for flush mounting. The plane of their mounting surfaces is not through the centerline of the cylinder, and for this reason side mounted cylinders produce a turning moment as the cylinder applies force to the load. (Fig. 4) This turning moment tends to rotate the cylinder about its mounting bolts. If the cylinder is not well secured to the machine member on which it is mounted or the load is not well-guided, this turning moment results in side load applied to rod gland and piston bearings. To avoid this problem, side mount cylinders should be specified with a stroke length at least equal to the bore size.

Shorter stroke, large bore cylinders tend to sway on their mountings when subjected to heavy loads, especially side end lug or side and angle mounts. (Fig. 5)

Side mount cylinders are available in two mounting styles; side lug (Style MS2) & Side tapped (Style MS4). Of these, the side lug mount is the most popular and reliable, since the mounting lugs are welded to head and cap to form an integral unit at each end. Side tapped mount is the choice when cylinders must be mounted side by side at minimum center-to-center distance.

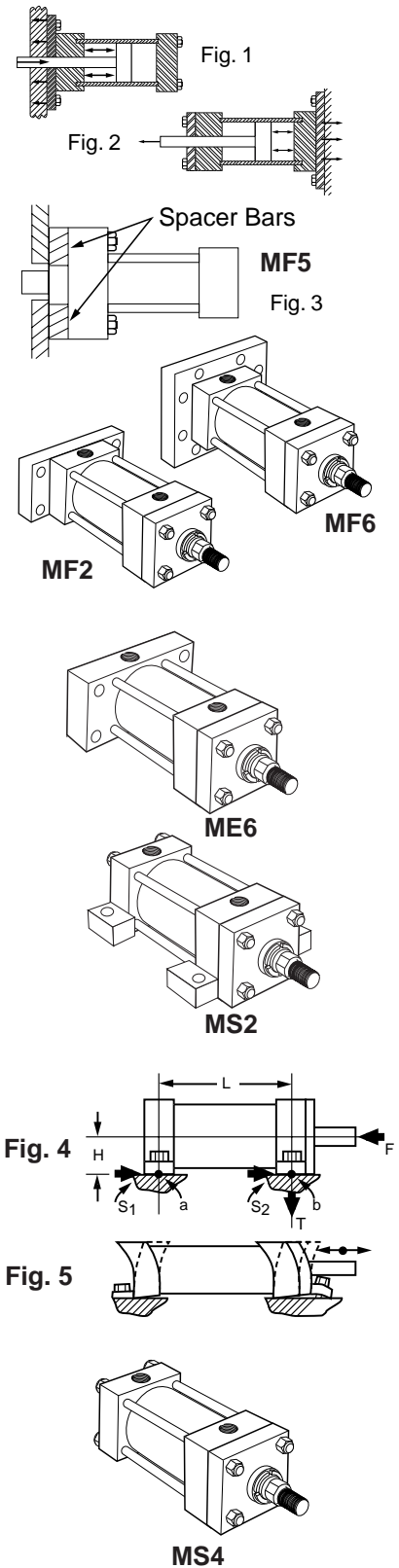

Consideration should also be given to design of the machine frame used to support cylinders non-centerline mount, since stronger members are often required to resist bending moments. (See Fig. 6)

Side mount cylinders depend wholly on the friction of their mounting surfaces in contact with the machine member to absorb the force produced. Thus the torque applied to the mounting bolts is an important consideration. Since the mounting bolts are the same diameter as the tie rods for a given cylinder, it is recommended that the torque applied to the mounting bolts be the same as the tie rod torque recommended by the cylinder manufacturer for the given bore size.

For heavy loads or high shock conditions, side mounted cylinders should be held in place to prevent shifting by keying or pinning. A shear key, consisting of a plate extending from side of cylinder, can be supplied on most cylinders. (Fig. 7) This method may be used where a keyway can be milled into a machine member. It serves to take up shear loads and also provides accurate alignment of the cylinder.

Side lug mounts are designed so as to allow dowel pins to be used to pin the cylinder to the machine member. Pins, when used, are installed on both sides of the cylinder but not at both ends. (See Fig. 8)

The use of a separate shear key is fairly common. It should be placed at the proper end of the cylinder to absorb the major load. (See Fig. 9)

Side mount cylinders should not be pinned or keyed at both ends. Changes in temperature and pressure under normal operating conditions cause the cylinder to increase (or decrease) in length from its installed length and therefore must be free to expand and contract. If pinned or keyed at both ends, the advantages of cylinder elasticity in absorbing high shock loads will be lost. (Fig. 10)

If high shock loads are the major consideration, the cylinder should be mounted and pins or shear key so located as to take full advantage of the cylinder's inherent elasticity. For major shock load in tension, locate key at rear face of head or pin the head in place. For major shock load in thrust, pin cap in place or locate key at front face of cap.

Pivot Force Transfer (Group 2)

Cylinders with pivot mounts which absorb force on centerline should be used on applications where the machine member to be moved travels in a curved path. There are two basic ways to mount a cylinder so that it will pivot during the work cycle: clevis or trunnion mounts, with variations of each. Pivot mount cylinders are available in cap fixed clevis (Style MP1), cap spherical bearing (Style MP3), head trunnion (Style MT1), cap trunnion (Style MT2), and intermediate fixed trunnion (Style MT4).

Pivot mount cylinders can be used on tension (pull) or thrust (push) applications at full rated pressure, except long stroke thrust cylinders are limited by piston rod column strength. See Piston Rod Selection Chart.

Clevis or single ear mounts are usually an integral part of the cylinder cap and provide a single pivot point for mounting the cylinder. A pivot pin of proper length and of sufficient diameter to withstand the maximum shear load developed by the cylinder at rated operating pressure is included as a part of the clevis mount style. The fixed clevis mount, Style MP1, is the most popular of the pivot force transfer types and is used on applications where the piston rod end travels in a curved path in one plane. It can be used vertically or horizontally or any angle in between. On long stroke push applications it may be necessary to use a larger diameter piston rod to prevent buckling or stop tube to minimize side loading due to "jackknife" action of cylinder in extended position. Fixed clevis mount cylinders will not function well if the curved path of piston rod travel is other than one plane. Such an application results in misalignment and causes the gland and piston bearing surfaces to be subjected to unnecessary side loading. For applications where the piston rod will travel in a path not more than 3° either side of the true plane motion, a cap spherical bearing mount is recommended. A spherical bearing rod eye should be used at rod end. Most spherical bearing mounts have limited pressure ratings. Consult cylinder manufacturer's product catalog.

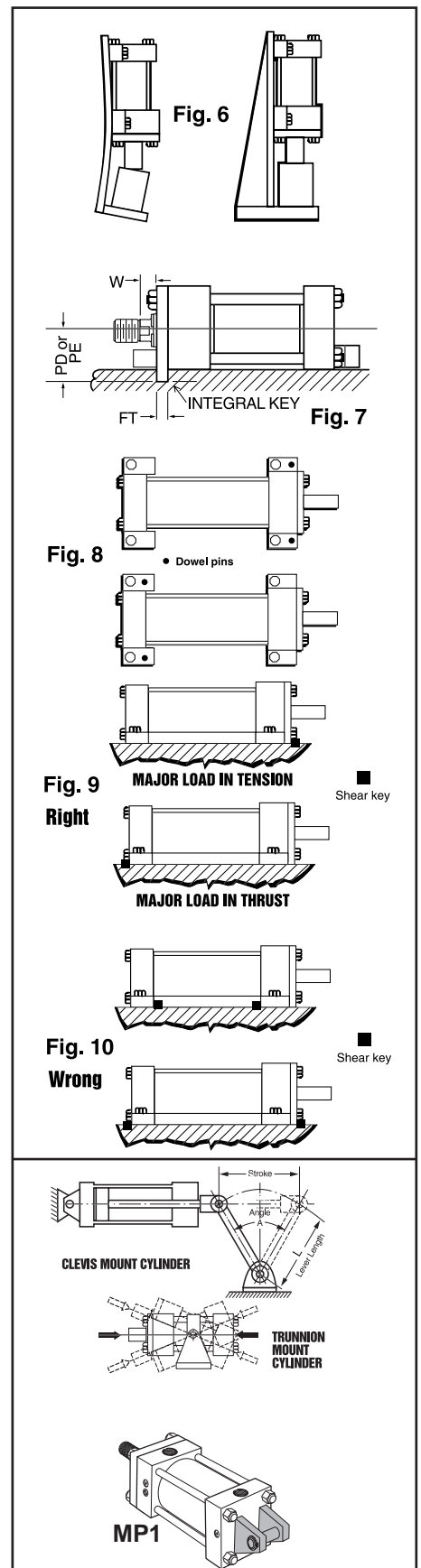

Mounting Information

Cap detachable clevis mounts are usually not available in heavy-duty hydraulic cylinders. They are used more for air or medium hydraulic service. Cap detachable clevis mounts are longer, centerline of pivot pin to shoulder of piston rod, than fixed clevis mount in any given bore size. They are most often specified to avoid port relocation charges. Application parameters are the same as described for fixed clevis mounting.

Trunnion mount cylinders are a second type of pivot mounts used on applications where the piston rod travels in a curved path in one plane. Three styles are available – head trunnion (Style MT1), cap trunnion (Style MT2) and intermediate fixed trunnion (Style MT4). Trunnion pins are designed for shear loads only and should not be subjected to bending stresses. Pillow blocks, rigidly mounted with bearings at least as long as the trunnion pins, should be used to minimize bending stresses. The support bearings should be mounted as close to the head, cap or intermediate trunnion shoulder faces as possible.

Cap end trunnion mounts are used on cylinder applications similar to fixed clevis mounts, and the same application data applies.

Head trunnion mount cylinders can usually be specified with smaller diameter piston rods than cylinders with pivot point at cap end or at an intermediate position. This is evident in data shown in piston rod selection chart. On head end trunnion mount, long stroke, cylinder applications consideration should be given to the overhanging weight at cap end of cylinder. To keep trunnion bearing loading within limits, stroke lengths should be not more than 5 times the bore size. If cylinder stroke is greater than 5 times the bore size and piston speed exceeds 35 ft/minute, consult factory.

Intermediate fixed trunnion mount is the best of the trunnion mount types. The trunnion can be located so as to balance the weight of the cylinder, or it can be located at any point between the head or cap to suit the application. It is of fixed design, and the location of the trunnion must be specified (X1) dimension) at time of order. The location cannot be easily changed once manufactured.

Thrust exerted by a pivot transfer cylinder working at an angle is proportional to the angle of the lever arm which it operates. In Fig. 12 that vector force, T, which is at right angle to the lever axis, is effective for turning the lever. The value of T varies with the acute angle A between cylinder centerline and lever axes. To calculate effective thrust T, multiply cylinder thrust by the power factor shown in table below.

Accessories

Rod clevises or rod knuckles are available for use with either fixed or pivot mount cylinders. Such accessories are usually specified with pivot mount cylinders and are used with pivot pin centerline in same axis as pivot pin centerline on cylinder. Pivot pins for accessories must be ordered separately.

Pin size of rod clevis or rod knuckle should be at least equal in diameter to the pin diameter of the cap fixed clevis pin for the cylinder bore size specified. Larger accessories are more costly and usually result in a mis-match of pin diameters, especially when used with oversize piston rods.

Removable Trunnion Pins

Removable trunnion pins are a convenience when machine structures or confined space prohibit the use of separate pillow blocks situated close to the cylinder sides. Schrader Bellows offers a removable pin design in 1-1/2" through 8" bores sizes. (See following table for recommended maximum operating pressure.) Mounting pin diameters and lengths are identical to those in Mounting Styles MT1 and MT2 for any given bore size. These removable trunnion pins can be provided on the cap end of Series "PA-2" cylinders with any rod diameter. They can also be provided on the head end of cylinders with standard rods.

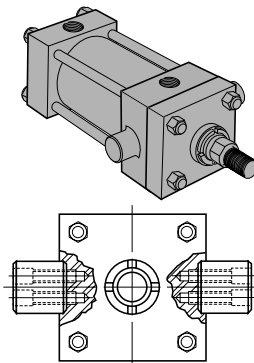

Pressure Ratings – Removable Trunnion Pin Mounting

Bore Size	1"	1 1/2"	2"	2 1/2"	3 1/4"	4"	5"	6"	8"
Std. Pressure Rating (PSI)	–	250	250	250	250	250	150	200	125
Extreme Pressure Rating	–	450	400	275	375	250	150	200	125
Hydraulic Rating (PSI)	–	750	700	450	625	400	250	325	200

Spherical Bearing Mount

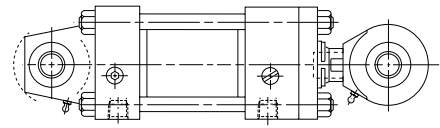
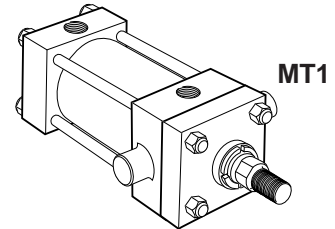
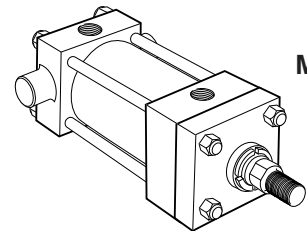

Fig. 11



MT1



MT2

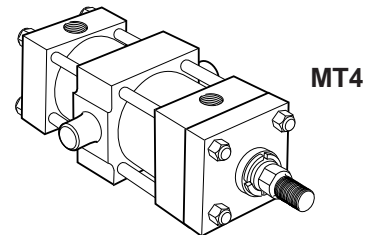

MT4

Clevis Mount Cylinder

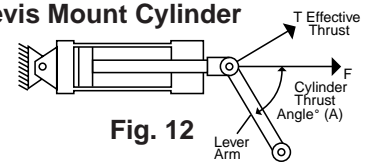

Fig. 12

Power Factor Table

Angle A Degrees	Pwr. Factor (SIN A)	Angle A Degrees	Pwr. Factor (SIN A)
5	0.087	50	0.766
10	0.174	55	0.819
15	0.259	60	0.867
20	0.342	65	0.906
25	0.423	70	0.940
30	0.500	75	0.966
35	0.573	80	0.985
40	0.643	85	0.996
45	0.707	90	1.000

Ports

Ports

Schrader Bellows hydraulic and pneumatic cylinders can be supplied with S.A.E. straight O-ring ports or N.P.T.F. pipe thread ports. For the type of port recommended and port size, see respective product catalogs. If specified on your order, extra ports can be provided on the sides of heads or caps that are not occupied by mountings or cushion valve on all cylinders.

Standard port location is position 1 as shown on line drawings in product catalog and Figure 1 below. Cushion adjustment needle and check valves are at positions 2 and 4 (or 3), depending on mounting style. Heads or caps which do not have an integral mounting can be rotated and assembled with ports at 90° or 180° from standard position. Mounting styles on which head or cap can be rotated at no extra charge are shown in Table A below. To order, specify by position number. In such assemblies the cushion adjustment needle and check valve rotate accordingly, since their relationship with port position does not change.

Figure 1

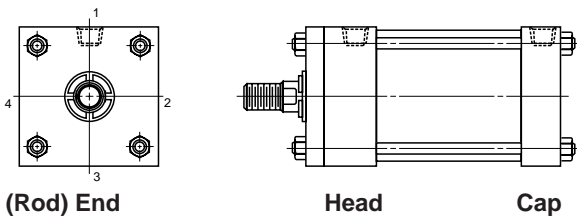

Head (Rod) End

Head

Cap

Table A

Mounting Style	Port Position Available	
	Head End	Cap End
MX0, MX1, MX2, MX3, MF2, MF5, MF6 MT4	1, 2, 3 or 4	1, 2, 3 or 4
ME6, MP1, MT2	1,2, 3 or 4	1 or 3
MF1, MT1	1 or 3	1, 2, 3 or 4
MS2, MS4	1	1

Applies to PL-2, PH-2, PH-3 Series.

Available Ports for PH-2, PH-3 Series Cylinders

Bore	SAE Standard	NPTF Pipe Thread	BSPP Parallel Thread	SAE 4-Bolt Flange Nom. Size	BSPT Taper Thread	Metric Straight Thread	ISO-6149-1 Metric Straight Thread
1 1/2	#10	1/2	1/2	N/A	1/2	M22 x 1.5	M22 x 1.5
2	#10	1/2	1/2	N/A	1/2	M22 x 1.5	M22 x 1.5
2 1/2	#10	1/2	1/2	1/2	1/2	M22 x 1.5	M22 x 1.5
3 1/4	#12	3/4	3/4	3/4	3/4	M27 x 2	M27 x 2
4	#12	3/4	3/4	3/4	3/4	M27 x 2	M27 x 2
5	#12	3/4	3/4	3/4	3/4	M27 x 2	M27 x 2
6	#16	1	1	1	1	M33 x 2	M33 x 2
7	#20	1 1/4	1 1/4	1 1/4	1 1/4	M42 x 2	M42 x 2
8	#24	1 1/2	1 1/2	1 1/2	1 1/2	M48 x 2	M48 x 2

Available Ports for PL-2 Series Cylinders

Bore	SAE Standard	NPTF Pipe Thread	BSPP Parallel Thread	BSPT Taper Thread	Metric Straight Thread	ISO-6149-1 Metric Straight Thread
1	#6	1/4	1/4	1/4	M14 x 1.5	M14x 1.5*
1 1/2	#6	3/8	3/8	3/8	M14 x 1.5	M14 x 1.5*
2	#6	3/8	3/8	3/8	M14 x 1.5	M14 x 1.5
2 1/2	#6	3/8	3/8	3/8	M14 x 1.5	M14 x 1.5
3/4	#10	3/8	3/8	3/8	M22 x 1.5	M22 x 1.5
4	#10	1/2	1/2	1/2	M22 x 1.5	M22 x 1.5
5	#10	1/2	1/2	1/2	M22 x 1.5	M22 x 1.5
6	#12	3/4	3/4	3/4	M26 x 1.5	M27 x 2
8	#12	3/4	3/4	3/4	M26 x 1.5	M27 x 2

*Not available on code II rods

Cylinder Port Options

SAE Straight Thread O-Ring Port. Recommended for most hydraulic applications.

Conventional NPTF Ports (Dry-Seal Pipe Threads). Recommended for pneumatic applications only.

BSPP Port (British Parallel Thread). ISO 228 port commonly used in Europe.

SAE Flange Ports Code 61 (3000 psi). Recommended for hydraulic applications requiring larger port sizes.

BSPT (British Tapered Thread).

Metric Straight Thread Port similar to BSPP with metric thread. Popular in some European applications.

ISO-6149-1 Metric Straight Thread Port. Recommended for all hydraulic applications designed per ISO standards.

Ports can be supplied at positions other than those shown in Table A at an extra charge. To order, specify port position as shown in Figure 1.

Straight Thread Ports

The S.A.E. straight thread O-ring port is recommended for hydraulic applications. Schrader Bellows will furnish this port configuration at positions shown in Table A on previous page. This port can also be provided at positions other than those shown in Table A at an extra charge. S.A.E. port size numbers are listed next to their N.P.T.F. pipe thread counterparts for each bore size in the respective product catalogs. Size number, tube O.D. and port thread size for S.A.E. ports are listed in Table C.

Table C
S.A.E. Straight Thread "O" Ring Ports

Size No.	Tube O.D. (In.)	Thread Size	Size No.	Tube O.D. (In.)	Thread Size
2	1/8"	5/16 - 24	12	3/4"	1 1/16 - 12
3	3/16"	3/8 - 24	—	—	—
4	1/4"	7/16 - 20	16	1"	1 5/16 - 12
5	5/16"	1/2 - 20	20	1 1/4"	1 5/8 - 12
6	3/8"	9/16 - 18	24	1 1/2"	1 7/8 - 12
8	1/2"	3/4 - 16	32	2"	2 1/2 - 12
10	5/8"	7/8 - 14	—	—	—

Note: For the pressure ratings of individual connectors, contact your connector supplier. Hydraulic cylinders applied with meter out or deceleration circuits are subject to intensified pressure at the cylinder piston rod end. The rod end pressure is approximately equal to:

$$\frac{\text{effective cap end piston area}}{\text{effective rod end piston area}} \times \text{Operating Pressure}$$

International Ports

Other port configurations to meet international requirements are available at extra cost. Schrader Bellows cylinders can be supplied, on request, with British standard taper port (BSPT). Such port has a taper of 1 in 16 measured on the diameter (1/16" per inch). The thread form is Whitworth System, and size and number of threads per inch are as follows:

Table D
British Standard Pipe Threads

Nominal Pipe Size	No. Threads Per Inch	Pipe O.D.
1/8	28	.383
1/4	19	.518
3/8	19	.656
1/2	14	.825
3/4	14	1.041
1	11	1.309
1 1/4	11	1.650
1 1/2	11	1.882
2	11	2.347

British standard parallel internal threads are designated as BSP and have the same thread form and number of threads per inch as the BSPT type and can be supplied, on request, at extra cost. Unless otherwise specified, the BSP or BSPT port size supplied will be the same nominal pipe size as the N.P.T.F. port for a given bore size cylinder.

Metric ports can also be supplied to order at extra cost.

Flange Ports (Code 61, 3000 psi)
SAE 4 Bolt Flange Ports for PH-2, PH-3 (7" & 8")

Bore Size	SAE Dash No.	Y	A	P	Q	W	X
2 1/2†	8	2.39	.50	2.97	1.50	.75	.34
3 1/4†	12	2.80	.75	3.41	1.87	.94	.44
		3.17					
		3.05					
4†	12	3.05	.75	3.66	1.87	.94	.44
		3.42					
		3.17					
5†	12	3.17	.75	4.16	1.87	.94	.44
		3.42					
		3.42					
6	16	3.52	1.00	4.58	2.06	1.03	.52
7	20	3.70	1.25	5.59	2.31	1.16	.59
8	24	3.84	1.50	6.31	2.75	1.37	.70

Bore Size	SAE Dash No.	Z	AA	GG
2 1/2†	8	5/16 - 18	.81	.69
3 1/4†	12	3/8 - 16	.75	.87
4†	12	3/8 - 16	.75	.87
5†	12	3/8 - 16	.75	.87
6	16	3/8 - 16	.87	1.03
7	20	7/16 - 14	1.00	1.19
8	24	1/2 - 13	1.06	1.41

†2 1/2", 3 1/4", 4" & 5" bores cap-flange port not available on MF6 mounting. MF2 mounting not available at position 2 or 4. Port flange overhangs cap on ME6 mounting.

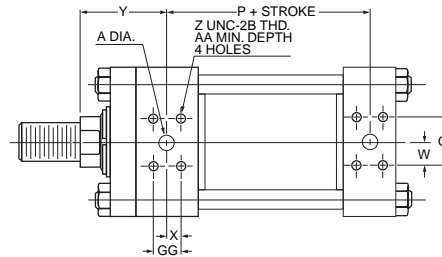

BSP or Metric Port for PL-2, PH-2, PH-3 Series

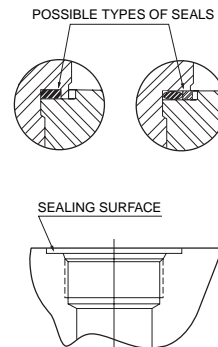

Figure R-G

ISO 6149-1 Port for PL-2, PH-2, PH-3 Series

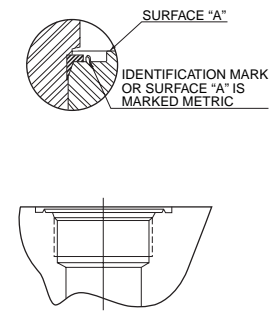

Figure Y

OverSize Ports

OverSize NPTF or SAE straight thread ports can be provided, at an extra charge, on pneumatic and hydraulic cylinders. For ports one size larger than standard, welded port bosses which protrude from the side of the head or cap are supplied. For dimensions, see drawings and tables below. PH-2 and PL-2 cylinders equipped with cushions at the cylinder cap end can sustain damage to the cushion check valve (cushion bushing) if excessive oil flow enters the cylinder from the cap end port. Cylinders which are equipped with cap end cushions and ordered with one size over size ports having hydraulic fluid flow exceeding 25 ft./sec. in the line entering the cap end of the

cylinder should be ordered with a "solid cushion" at cap end. All cylinders ordered with double over size ports should always be ordered with a "solid cushion" at cap end.

Cylinders which are connected to a meter out flow control with flow entering the cap end of a cylinder provided by an accumulator may also experience damage to the cushion bushing due to high instantaneous fluid flows. This condition can be eliminated by using a meter in flow control or "solid cushions" at cap end.

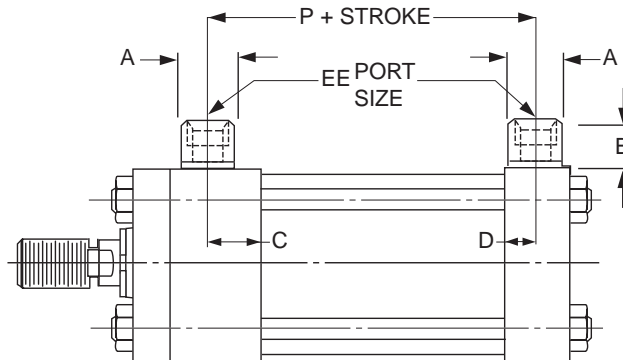

**OverSize NPTF Port Boss Dimensions
PA-2 and PL-2 Series Cylinders**

Bore	EE (NPTF)	A (Dia.)	B	C	D	P
1	3/8	7/8	3/4	9/16	1/2	2 1/16
1 1/2	1/2	1 1/8	15/16	9/16	1/2	2 3/16
2	1/2	1 1/8	15/16	9/16	1/2	2 3/16
2 1/2	1/2	1 1/8	15/16	9/16	1/2	2 5/16
3 1/4	3/4	1 3/8	1	11/16	5/8	2 9/16
4	3/4	1 3/8	1	11/16	5/8	2 9/16
5	3/4	1 3/8	1	11/16	5/8	2 13/16
6	1	1 3/4	1 3/16	15/16	3/4	3 3/16
7-8	1	1 3/4	1 3/16	15/16	3/4	3 5/16
10	1 1/4	2 1/4	1 5/16	1 1/8	1	4 1/4
12	1 1/4	2 1/4	1 5/16	1 1/8	1	4 3/4
14	1 1/2	2 1/2	1 9/16	1 1/4	1 1/8	5 1/2

**OverSize SAE Straight Thread
Port Boss Dimensions
PL-2 Series Cylinders**

Bore	EE (SAE)	A (Dia.)	B	C	D	P
1	8	1 1/8	15/16	9/16	1/2	2 1/16
1 1/2	8	1 1/8	15/16	9/16	1/2	2 3/16
2	8	1 1/8	15/16	9/16	1/2	2 3/16
2 1/2	8	1 1/8	15/16	9/16	1/2	2 5/16
3 1/4	12	1 3/8	1	11/16	5/8	2 9/16
4	12	1 3/8	1	11/16	5/8	2 9/16
5	12	1 3/8	1	11/16	5/8	2 13/16
6	16†	1 3/4	1 3/16	15/16	3/4	3 3/16
8	16†	1 3/4	1 3/16	15/16	3/4	3 5/16

PH-2, PH-3 Series (7" & 8") Cylinders

Bore	EE (NPTF)	A (Dia.)	B	C	D	P
1 1/2	3/4	1 3/8	1	3/4	25/32	2 29/32
2	3/4	1 3/8	1	3/4	25/32	2 29/32
2 1/2	3/4	1 3/8	1	3/4	25/32	3 1/32
3 1/4	1	1 3/4	1 3/16	29/32	7/8	3 17/32
4	1	1 3/4	1 3/16	29/32	7/8	3 25/32
5	1	1 3/4	1 3/16	29/32	7/8	4 9/32
6	1 1/4	2 1/4	1 5/16	1 1/8	1 1/8	5 1/8
7	1 1/2	2 1/2	1 9/16	1 3/8	1 3/8	5 3/4
8	2	3	1 11/16	1 1/2	1 1/2	6 1/2

PH-2, PH-3 Series (7" & 8")

Bore	EE (SAE)	A (Dia.)	B	C	D	P
1 1/2	12	1 3/8	1	13/16	25/32	2 31/32
2	12	1 3/8	1	13/16	25/32	2 31/32
2 1/2	12**	**	**	**	**	3 5/32
3 1/4	16	1 3/4	1 3/16	7/8	7/8	3 7/16
4	16	1 3/4	1 3/16	7/8	7/8	3 11/16
5	16	1 3/4	1 3/16	7/8	7/8	4 3/16
6	20**	**	**	**	**	5 3/16
7	24**	**	**	**	**	5 1/2
8	32**	**	**	**	**	6 1/4

†Available at head end only. For cap end, consult factory.
**Port tapped directly into head and cap.

Manifold Ports

Side mounted cylinders, Style MS2 can be furnished with the cylinder ports arranged for mounting and sealing to a manifold surface. The ports are drilled and counterbored for O-ring seals which are provided.

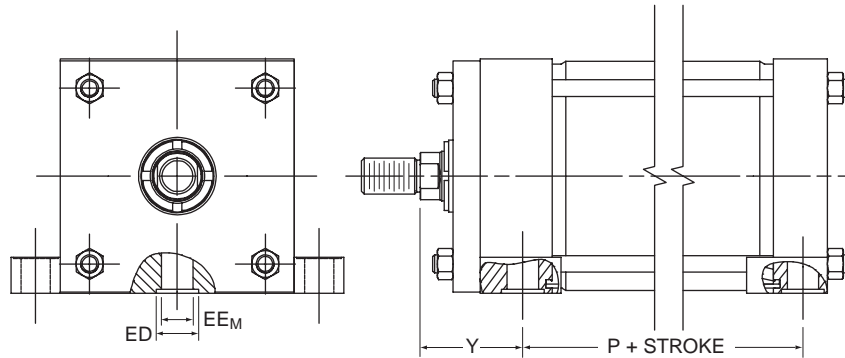

**Dimensions —
Manifold Ports for Single and Double Rod Cylinders
PH-2, PH-3 Series (7" & 8") Cylinders**

Bore	Rod Dia. (MM)	Y±1/32	P±1/32	PK±1/32	EEM	ED
1½	5/8	2	2 ⁷ / ₈	2 ⁷ / ₈	¾	1 ¹ / ₈
	1	2 ³ / ₈				
2	1	2 ³ / ₈	2 ⁷ / ₈	2 ⁷ / ₈	¾	1 ¹ / ₈
	1 ³ / ₈	2 ³ / ₈				
2½	1	2 ³ / ₈	3	3	¾	1 ¹ / ₈
	1 ³ / ₄	2 ⁷ / ₈				
	1 ³ / ₈	2 ⁵ / ₈				
3¼	1 ³ / ₈	2 ³ / ₄	3½	3½	1	1 ³ / ₈
	2	3 ¹ / ₈				
	1 ³ / ₄	3				
4	1 ³ / ₄	2 ²⁷ / ₃₂	4	4 ¹ / ₁₆	1	1 ³ / ₈
	2½	3 ⁷ / ₃₂				
	2	2 ³¹ / ₃₂				
5	2	3 ¹ / ₈	4¼	4¼	1	1 ³ / ₈
	3½	3 ³ / ₈				
	2½					
	3					
6	2½		3½	5½	4 ⁷ / ₈	1¼
	4					
	3					
7	3½	3 ¹³ / ₁₆	5 ⁷ / ₈	5 ⁵ / ₈	1½	1 ⁷ / ₈
	5					
	4					
	4½					
	3½					
8	5½	3 ¹⁵ / ₁₆	6 ⁵ / ₈	6 ¹ / ₈	1½	1 ⁷ / ₈
	4					
	4½					
	4					
	5					

PA-2, PL-2 Series Cylinders

Bore	Rod Dia. (MM)	Y±1/32	P±1/32	EEM	ED
1	All	1 ¹⁵ / ₁₆	2 ¹ / ₈	¾	1 ¹¹ / ₁₆
1½	5/8	2	2 ¹ / ₈	½	1 ³ / ₁₆
	1	2 ³ / ₈			
2	5/8	2	2 ¹ / ₈	½	1 ³ / ₁₆
	1 ³ / ₈	2 ³ / ₈			
	1	2 ³ / ₈			
2½	5/8	2	2¼	½	1 ³ / ₁₆
	1 ³ / ₄	2 ⁷ / ₈			
	1	2 ³ / ₈			
3¼	1 ³ / ₈	2 ⁵ / ₈	2 ⁵ / ₈	5/8	1 ⁵ / ₁₆
	1	2 ⁷ / ₁₆			
	2	3 ¹ / ₁₆			
	1 ³ / ₈	2 ¹¹ / ₁₆			
4	1 ³ / ₄	2 ¹⁵ / ₁₆	2 ⁵ / ₈	5/8	1 ⁵ / ₁₆
	1	2 ⁷ / ₁₆			
	2½	3 ⁵ / ₁₆			
	1 ³ / ₈	2 ¹¹ / ₁₆			
	1 ³ / ₄	2 ¹⁵ / ₁₆			
	2	3 ¹ / ₁₆			
5	1	2 ⁷ / ₁₆	2 ⁷ / ₈	5/8	1 ⁵ / ₁₆
	3½, 2½ & 3	3 ⁵ / ₁₆			
	1 ³ / ₈	2 ¹¹ / ₁₆			
	1 ³ / ₄	2 ¹⁵ / ₁₆			
	2	3 ¹ / ₁₆			
6	1 ³ / ₈	2 ¹³ / ₁₆	3 ¹ / ₈	7/8	1 ³ / ₁₆
	4, 2½, 3 & 3½	3 ⁷ / ₁₆			
	1 ³ / ₄	3 ¹ / ₁₆			
	2	3 ³ / ₁₆			
7 - 8	1 ³ / ₈	2 ¹³ / ₁₆	3¼	7/8	1 ³ / ₁₆
	5½, 2½, 3, 3½, 4, 4½ & 5	3 ⁷ / ₁₆			
	1 ³ / ₄	3 ¹ / ₁₆			
	2	3 ³ / ₁₆			
10	1 ³ / ₄	3 ¹ / ₈	4 ¹ / ₈	1 ³ / ₁₆	1½
	2	3¼			
	2½, 3, 3½, 4, 4½, 5 & 5½	3½			
12	2	3¼	4 ⁵ / ₈	1 ³ / ₁₆	1½
	2½, 3, 3½, 4, 4½, 5 & 5½	3½			
14	All	3 ¹³ / ₁₆	5½	1 ⁹ / ₁₆	1 ⁷ / ₈

Rod End Data

Rod end dimension symbols as shown comply with the National Fluid Power Association dimensional code. The following chart indicates the symbols used in this catalog.

Description	Symbol
Thread diameter and pitch	KK or CC
Length of thread	A
Length of rod extension from face of gland retainer to end of retracted rod	A + W (Male Thread) W (Female Thread)

Three rod ends for Schrader Bellows cylinders are offered as shown on the dimension pages of this catalog. They are Schrader Bellows styles 2, 3 and 4, and all three are optional without price penalty. If a rod end style is not specified, style 2 (N.F.P.A. Style SM) will be supplied. Style 2 is supplied with high strength rolled thread studs on piston rods through 2" diameter. Longer studs in standard sizes are available, see table below.

Warning!

Piston rods are not normally designed to absorb bending moments or loads which are perpendicular to the axis of piston rod motion. These additional loads can cause the piston rod end to fail. If these types of additional loads are expected to be imposed on the piston rods, their magnitude should be made known to our Engineering Department so they may be properly addressed. Additionally, cylinder users should always make sure that the piston rod is securely attached to the machine member.

On occasion cylinders are ordered with double rods. In some cases a stop is threaded onto one of the piston rods and used as an external stroke adjuster. This can cause a potential safety concern and can also lead to premature piston rod failure. The external stop will create a pinch point and the cylinder user should consider appropriate use of guards. If an external stop is not parallel to the final contact surface it will place a bending moment on the piston rod. An external stop will also negate the effect of a cushion and will subject the piston rod to an impact loading. These two (2) conditions can cause piston rod failure. The use of external stroke adjusters should be reviewed with our Engineering Department.

Piston Rod End Threads

Standard piston rod end thread lengths are shown as dimension "A" in Catalog dimension pages. Special rod end threads which are two times standard length can be supplied at a small extra cost. Available thread lengths are shown in the table below. To order, add suffix "2" to piston rod model number code and specify as Style #22.

Optional Piston Rod End Studs

Piston Rod Dia.	Rod End Thread Style #2	
	Thread Dia. & Pitch (KK)	Length (= 2 x A)
$\frac{5}{8}$	$\frac{7}{16}$ - 20	1 $\frac{1}{2}$
1	$\frac{3}{4}$ - 16	2 $\frac{1}{4}$
1 $\frac{3}{8}$	1 - 14	3 $\frac{1}{4}$
1 $\frac{3}{4}$	1 $\frac{1}{4}$ - 12	4
2	1 $\frac{1}{2}$ - 12	4 $\frac{1}{2}$

International Rod End Threads

Piston rod threads to meet international requirements are available at extra cost. Schrader Bellows cylinders can be supplied with British standard fine (W) or metric (M). To order, specify in model number. For dimensions, consult factory.

Special Rod Ends

If a rod end configuration other than the standard styles 2, 3 and 4 is required, such special rod ends can be provided. The designation "Style 0" is assigned to such specials and is incorporated in the cylinder model number. To order, specify "Style 0" and give desired dimensions for CC or KK, A, LA or LAF, or W if female end. If otherwise special, send a dimensioned sketch.

Special Assemblies from Standard Parts

Each dimensioned drawing in this catalog has position numbers shown on the end view to identify the four sides of the cylinder. These aid in communications and simplify the writing of specifications that cover changes in port positions, etc. Following are several suggested special assemblies that can be made up from standard parts.

- By calling out the position numbers for the desired locations for head and cap ports, many mounting styles can be assembled with ports located at 90° or 180° from standard. In such special assemblies, the cushion needle and check valves are also repositioned since their relation with the port position does not change.
- The cushion needle valve can be assembled on side position 4 with the check valve on side 2 or most mounting styles when the port is in the standard side position 1. On mounting styles MT1, MT2 and MT4, the cushion needle valves are provided only on the side position 3 on the head or cap which accommodates the mounting. The opposite head or cap can be rotated.
- Standard mountings in different combinations can be specified on either head or cap end. Consult factory for details.

Single-Acting Cylinders

Double-acting cylinders are supplied as standard. They can also be used as single-acting cylinders where fluid force is applied to only one side of the piston, with the load or other external forces acting to "return" the piston after pressure is exhausted.

Spring-Returned, Single-Acting Cylinders – Single-acting, spring-returned models can also be provided. Load conditions and friction factors must be considered in supplying the proper spring for the application. In addition, it is necessary that information be supplied as to which side of the piston the spring should act upon. Specify "Spring to return piston rod" or "Spring to advance piston rod."

On longer stroke spring-returned cylinders, it is recommended that tie rod extensions be specified on the cylinder end in which the spring is located so that the cap or head against which the spring is acting can be "backed-off" slowly until compression of the spring is relieved. In such cases it should also be specified that the tie rod nuts be welded to the tie rods at the opposite end of the cylinder to further insure safe disassembly.

Consult factory when ordering spring-returned cylinders.

Stroke Data

Schrader Bellows cylinders are available in any practical stroke length. The following information should prove helpful to you in selecting the proper stroke for your cylinder application.

Stroke Tolerances

Stroke length tolerances are required due to buildup of tolerances of piston, head, cap and cylinder body. Standard production stroke tolerances run $+1/32"$ to $-1/64"$ up to 20" stroke, $+1/32"$ to $-.20"$ for 21" to 60" and $+1/32"$ to $-1/32"$ for greater than 60" stroke. For closer tolerances on stroke length, it is necessary to specify the required tolerance plus the operating pressure and temperature at which the cylinder will operate. Stroke tolerances smaller than .015" are not generally practical due to elasticity of cylinders. If machine design requires such close tolerances, use of a stroke adjuster (at right) may achieve the desired result.

Tie Rod Supports

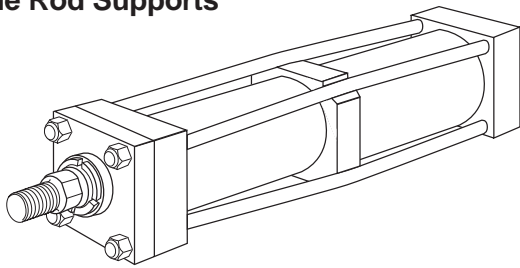

Rigidity of Envelope

The pre-stressed tie rod construction of Schrader Bellows cylinders has advantages in rigidity within the limits of the cylinder tube to resist buckling. For long stroke cylinders within practical limits, Schrader Bellows provides exclusive TIE ROD SUPPORTS (see table below) which move the tie rod centerlines radially outward.

Standard tie rod supports are kept within the envelope dimensions of the head and cap, and generally do not interfere with mounting a long cylinder.

Number of Supports Required	Stroke (Inches)														
	Bore	36	48	60	72	84	96	108	120	132	144	156	168		
1	—	1	1	1	2	Consult Factory									
1 1/2	—	—	1	1	1	2	2	2	3	3	3	3	4		
2	—	—	—	1	1	1	1	2	2	2	2	2	3		
2 1/2	—	—	—	—	—	1	1	1	1	1	2	2			
3 1/4	—	—	—	—	—	—	—	1	1	1	1	1	1		
4	—	—	—	—	—	—	—	—	—	1	1	1	1		

Note: 5" through 14" bore sizes — no supports required.

Stroke Adjusters

For the requirement where adjusting the stroke is specified, Schrader Bellows has several designs to offer, one of which is illustrated below. This is suitable for infrequent adjustment and is economical.*

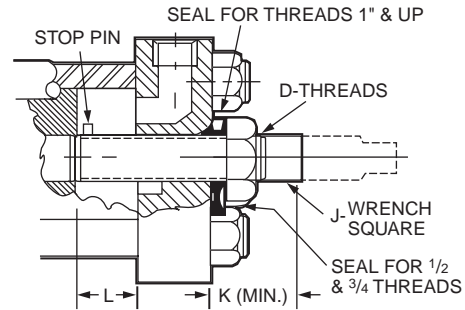

Here a "retracting stroke adjuster" must be called for in specifications, and the length of the adjustment must be specified.

Where frequent adjustment or cushions at the cap end are required, other designs are available according to application needs.

Bore Size		D	J	K	L (Max.)
PA-2 PL-2 Series	PH-2 Series				
1 1/2, 2	1 1/2	1/2 - 20	5/16	15/16	5
2 1/2, 3 1/4, 4	2	3/4 - 16	7/16	1 1/4	8
5, 6	2 1/2, 3 1/4	1 - 14	5/8	1 1/16	9
8	4	1 1/2 - 12	15/16	2 1/8	18
10	5	2-12	1 5/16	2 11/16	20
12, 14	6	2 1/2 - 12	1 11/16	3 1/8	20
—	7	3-12	2	3 1/4	20
—	8	3 1/2 - 12	2 3/8	3 1/2	20

* Infrequent is defined by positioning the retract stroke in a couple of attempts at original machine set-up. The frequent stroke adjuster is recommended when adjustments may be required by the end user.

Rod Gland Drain

Rod gland drains permit capture of fluid that may accumulate between the primary rod seal and the wiperseal. A 1/8 NPTF port is provided in the gland retainer or cylinder head (see table below) for connection of plumbing that flows oil back to the reservoir. Use of translucent tubing as the drain to reservoir line can provide visual indication of a need for rod seal service when the cylinder gland is not easily visible within the equipment. Specify rod gland drain port option and the drain port location, position 1, 2, 3, or 4.

Drain Port Location

Bore	Rod Dia.	MX2, MX0, MF2, MF6, ME6, MS2 (no key), MS4 (no key), MT1, MT2, MP1, MT4, MPU3	MX1 MX3	MF1 MF5	ME5	MS2, MS4 With Thrust Key Plate
1 1/2	5/8	Head	Head	Head	Head	Head
	1	Full	Full	Flange	Head	Key
2	1	Bolted	Full	Flange	Head	Key
	1 3/8	Full	Full	Flange	Head	Key
2 1/2	1	Bolted	Bolted	Flange	Head	Head
	1 3/8	Bolted	Bolted	Flange	Head	Head
	1 3/4	Bolted	Bolted	Flange	Head	Key
3 1/4	All	Bolted	Bolted	Flange	Head	Head
4	All	Bolted	Bolted	Head	Head	Head
5	2 - 3	Bolted	Bolted	Head	Head	Head
	3 1/2	Bolted	Bolted	Flange	Head	Key
6 - 8	All*	Bolted	Bolted	Head	Head	Head

* On 5 1/2" diameter piston rods, with drain in position 2 or 4, the port will be offset 18 degrees clockwise from the position specified.

Bolted = Bolted Retainer
Flange = Flange Retainer

Full = Full Retainer
Key = Key Retainer

The full square retainer, key retainer, or mounting flange thickness is increased on bore and rod combinations listed in the table below. The piston rod is extended on MX1, MX3, MF5, and MF1 mounts to provide the standard 'W' dimension.

Bore	Rod Dia.	Retainer or Mounting Flange Thickness
1 1/2	1	5/8
2	1 3/8	3/4
2 1/2	1 3/4	7/8
3 1/4	1 3/4 & 2	7/8

Thrust Key Mountings

Thrust key mountings eliminate the need of using fitted bolts or external keys on side mounted cylinders. Schrader Bellows cylinders in mounting styles MS2 and MS4 can be provided with the gland retainer plate extended below the mounting side of the cylinder (see illustration below). This extended retainer plate can then be fitted into a keyway milled into the mounting surface of the machine member.

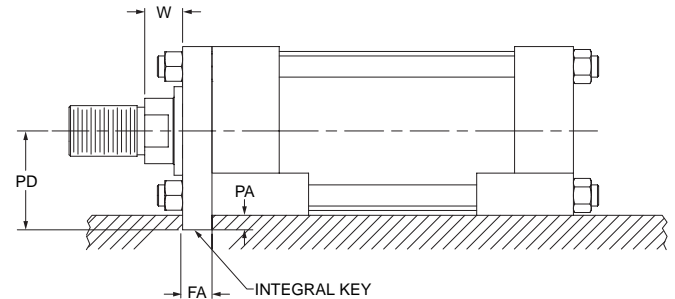

PA-2, PN and PL-2 Series

Bore	Dim. FA	Dim. PA	Dim. PD Mtg. Styles MS2, MS4
1	.312 +.000 -.002	3/16	15/16
1 1/2			1 3/16
2			1 7/16
2 1/2	.562 +.000 -.002	5/16	1 11/16
3 1/4			2 3/16
4			2 9/16
5	.687 +.000 -.002	3/8	3 1/16
6			3 5/8

PH-2, PH-3 Series (7" & 8") Cylinders

Bore	+ .000 / - .001 Dim. FA	Dim. PA	Dim. PD Mtg. Styles MS2, MS4
1 1/2	.361	3/16	1 7/16
2	.611	5/16	1 13/16
2 1/2	.611	5/16	2 1/16
3 1/4	.736	3/8	2 5/8
4	.861	7/16	2 15/16
5	.861	7/16	3 11/16
6	.986	1/2	4 1/4
7	.986	1/2	4 3/4
8	.986	1/2	5 1/4



Stop Tubing

Long stroke cylinders, fixed or pivot mounted, tend to jack-knife or buckle on push load applications, resulting in high bearing loading at the rod gland or piston. Use of a stop tube to lengthen the distance between the gland and piston when cylinder rod is fully extended is recommended to reduce these bearing loads. The drawing below shows stop tube construction for fluid power cylinders. Refer to piston rod/stroke selection chart to determine stop tube length.

Drawing A

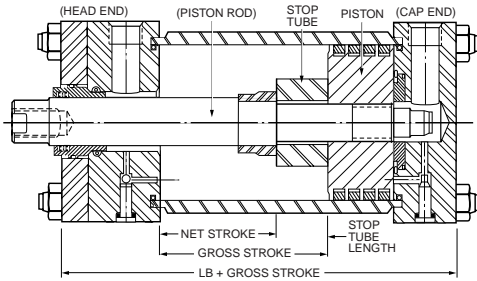

When specifying cylinders with long stroke and stop tube, be sure to call out the net stroke and the length of the stop tube. Machine design can be continued without delay by laying in a cylinder equivalent in length to the NET STROKE PLUS STOP TUBE LENGTH, which is referred to as GROSS STROKE. Refer to piston rod/stroke selection chart to determine stop tube length.

Drawing B

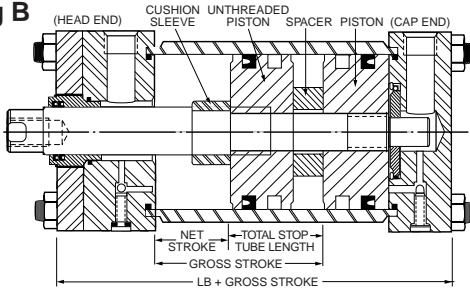

Double piston design is supplied on air cylinders with cushion head end or both ends.

Drawing C

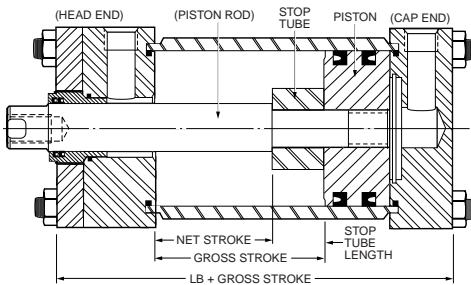

This design is supplied on all non cushion cylinders.

PA-2, PH-2, PL-2 Series Cylinders

Mounting Classes

Standard mountings for fluid power cylinders fall into three basic groups. The groups can be summarized as follows:

- Group 1 – Straight Line Force Transfer with fixed mounts which absorb force on cylinder centerline.
- Group 2 – Pivot Force Transfer. Pivot mountings permit a cylinder to change its alignment in one plane.
- Group 3 – Straight Line Force Transfer with fixed mounts which do not absorb force on cylinder centerline.

Because a cylinder's mounting directly affects the maximum pressure at which the cylinder can be used, the chart below should be helpful in selection of the proper mounting combination for your application. Stroke length, piston rod connection to load, extra piston rod length over standard, etc., should be considered for thrust loads. Alloy steel mounting bolts are recommended for all mounting styles, and thrust keys are recommended for Group 3.

Group 1 FIXED MOUNTS which absorb force on cylinder centerline.	
Heavy-Duty Service For Thrust Loads For Tension Loads	Mtg. Styles MF6, MX2 Mtg. Styles MF5, MX3
Medium-Duty Service For Thrust Loads For Tension Loads	Mtg. Styles MF2, MF5 Mtg. Styles MF1, MF6
Light-Duty Service For Thrust Loads For Tension Loads	Mtg. Style MF1 Mtg. Style MF2
Group 2 PIVOT MOUNTS which absorb force on cylinder centerline.	
Heavy-Duty Service For Thrust Loads For Tension Loads	Mtg. Styles MT4 Mtg. Styles MP1, MP2, MT1, MT2, MT4
Medium-Duty Service For Thrust Loads For Tension Loads	Mtg. Styles MP1, MP2 Mtg. Styles MP1, MP2
Light-Duty Service For Thrust Loads For Tension Loads	=====
Group 3 FIXED MOUNTS which do not absorb force on the centerline.	
Heavy-Duty Service For Thrust Loads For Tension Loads	Mtg. Style MS2 Mtg. Style MS2
Medium-Duty Service For Thrust Loads For Tension Loads	Mtg. Style MS4 Mts. Style MS4

Piston Rod — Stroke Selection Chart

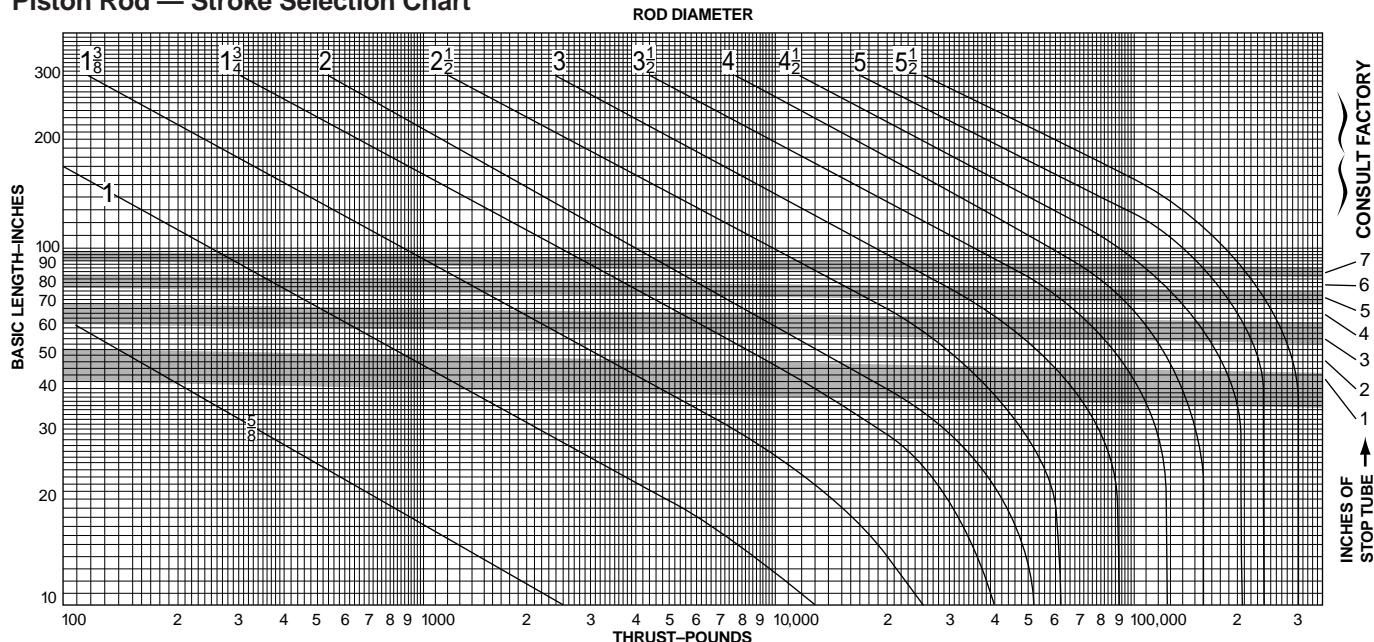

How to Use the Chart

The selection of a piston rod for thrust (push) conditions requires the following steps:

- Determine the type of cylinder mounting style and rod end connection to be used. Then consult the chart below and find the "stroke factor" that corresponds to the conditions used.

- Using this stroke factor, determine the "basic length" from the equation:

$$\text{Basic Length} = \frac{\text{Actual Stroke}}{\text{Stroke Factor}}$$

The graph is prepared for standard rod extensions beyond the face of the gland retainers. For rod extensions greater than standard, add the increase to the stroke in arriving at the "basic length."

- Find the load imposed for the thrust application by multiplying the full bore area of the cylinder by the system pressure.

- Enter the graph along the values of "basic length" and "thrust" as found above and note the point of intersection:

A) The correct piston rod size is read from the diagonally curved line labeled "Rod Diameter" next above the point of intersection.

B) The required length of stop tube is read from the right of the graph by following the shaded band in which the point of intersection lies.

C) If required length of stop tube is in the region labeled "consult factory," submit the following information for an individual analysis:

- Cylinder mounting style.
- Rod end connection and method of guiding load.
- Bore, required stroke, length of rod extension (Dim. "LA") if greater than standard, and series of cylinder used.
- Mounting position of cylinder. (Note: If at an angle or vertical, specify direction of piston rod.)
- Operating pressure of cylinder if limited to less than standard pressure for cylinder selected.

Warning ⚠

Piston rods are not normally designed to absorb bending moments or loads which are perpendicular to the axis of piston rod motion. These additional loads can cause the piston rod end to fail. If these types of additional loads are expected to be imposed on the piston rods, their magnitude should be made known to our Engineering Department so they may be properly addressed. Additionally, cylinder users should always make sure that the piston rod is securely attached to the machine member.

Recommended Mounting Styles for Maximum Stroke and Thrust Loads	Rod End Connection	Case	Stroke Factor
Groups 1 or 3 Long stroke cylinders for thrust loads should be mounted using a heavy-duty mounting style at one end, firmly fixed and aligned to take the principal force. Additional mounting should be specified at the opposite end, which should be used for alignment and support. An intermediate support may also be desirable for long stroke cylinders mounted horizontally. See "Tie Rod Supports — Rigidity of Envelope" for a guide. Machine mounting pads can be adjustable for support mountings to achieve proper alignment.	Fixed and Rigidly Guided	I	.50
	Pivoted and Rigidly Guided	II	.70
	Supported but not Rigidly Guided	III	2.00
Group 2 Style MT1 — Trunnion on Head	Pivoted and Rigidly Guided	IV	1.00
Style MT4 — Intermediate Trunnion	Pivoted and Rigidly Guided	V	1.50
Style MT2 — Trunnion on Cap or Style MP1 — Clevis on Cap	Pivoted and Rigidly Guided	VI	2.00



An Introduction to Cushioning

Cushioning is recommended as a means of controlling the deceleration of masses, or for applications where piston speed is in excess of 4 in/sec and the piston will make full stroke. Cushioning extends cylinder life and reduces undesirable noise and hydraulic shock. Built-in "cushions" are optional and can be supplied at the head and cap ends of a cylinder without affecting its envelope or mounting dimensions.

Standard Cushioning

Ideal cushion performance shows an almost uniform absorption of energy along the cushioning length, as shown. Many forms of cushioning exist, and each has its own specific merits and advantages.

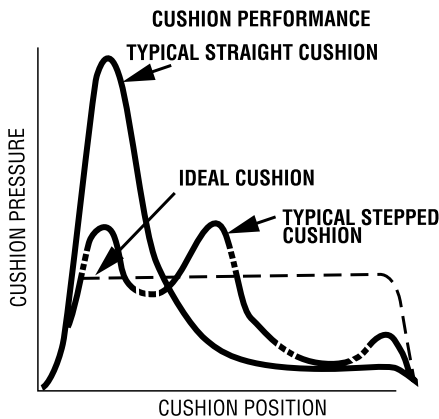

In order to cover the majority of applications, PH-2/PH-3 cylinders are supplied with profiled cushioning as standard. Final speed may be adjusted using the cushion screw. The performance of profiled cushioning is indicated on the diagram, and cushion performance for

each of the rod sizes available is illustrated graphically in the charts on the following pages.

Note: Cushion performance will be affected by the use of water or high water based fluids. Please consult factory for details.

Cushion Length

Where specified, PH-2/PH-3 cylinder incorporates the longest cushion sleeve and spear that can be accommodated within the standard envelope without reducing the rod bearing and piston bearing length. See cushion lengths on the next page. Cushions are adjustable via recessed needle valves.

Cushion Calculation

The charts on the next page show the energy absorption capacity for each bore/rod combination at the head (annulus) and the cap (full bore) ends of cylinder. The charts are valid for piston velocities within a range of 0.33 to 1 ft/s. For velocities between 1ft/s and 1.64 ft/s the energy values derived from the charts should be reduced by 25%. For velocities less than 0.33 ft/s where large masses are involved, and for velocities greater than 1.60 ft/s, a special cushion profile may be required. Please consult the factory for details.

The cushion capacity of the head end is less than the cap, and reduces to zero at high drive pressures due to the pressure intensification effect across the piston.

The energy absorption capacity of the cushion decreases with drive pressure.

Formula

Cushioning calculations are based on the formula $E=(1/2) mv^2$ for horizontal applications. For inclined or vertically downward or upward applications, this is modified to:

$$E = (1/2)mv^2 + mg(L/12) \times \sin(a)$$

(for inclined or vertically downward direction of mass)

$$E = (1/2)mv^2 - mg(L/12) \times \sin(a)$$

(for inclined vertically upward direction of mass)

where:

E = energy absorbed in ft-lb

g = acceleration due to gravity = 32.2 ft/s²

v = velocity in ft/s

L = length of cushion in inches

m = mass of load in slug (including piston, rod and rod end accessories).

a = angle to the horizontal in degrees

p = pressure in psi

Example:

The following example shows how to calculate the energy developed by masses moving in a straight line. For non-linear motion, other calculations are required; please consult the factory. The example assumes that the bore and rod diameter are already appropriate for the application. The effects of friction on the cylinder and load have been ignored.

Selected bore/rod 6" bore x 2 1/2" rod (No. 1 rod)

Cushion at the cap end.

Pressure = 2,500 psi

Mass = 685 slugs = weight in lb / (32.2 ft/s²)

Velocity = 1.3 ft/s

Cushion length = 1.313 inch

a = 45°

Sin (a) = 0.70

$$E = (1/2)mv^2 + mgl/12 \times \sin(a)$$

$$= (1/2) \times 685 \times 1.3^2 + 685 \times 32.2 \times 1.313/12 \times 0.70$$

$$= 2,268 \text{ ft-lb}$$

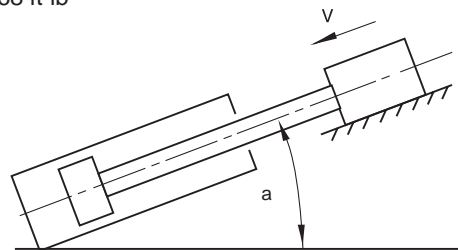

Note: In the above example velocity is greater than 1 ft./s. Therefore, a de-rating factor of 0.75 must be applied to the calculated value of E. Applying this correction factor will increase the energy value to 3024 ft.-lb. (2268/0.75 = 3024 ft.-lb.). A review of the graph for the cap end cushion of a 6 inch bore x 2 1/2" rod cylinder operating at 2500 psi indicates that it can absorb approximately 3200 ft.-lb. maximum of energy. Since 3024 ft.-lbs. is less than the maximum allowable of 3200 ft.-lbs., the cylinder can be applied as indicated. If the calculated energy exceeds the value shown on the curve, select a larger bore cylinder and/or reduce the operating pressure and recalculate the energy. Compare the newly calculated energy value to the appropriate curve to ensure it does not exceed the maximum allowable energy.

BORE	ROD DIA.	CUSHION LENGTH (MINIMUM)	
		HEAD	CAP
1.5	0.625	0.924	1.000
	1.000	0.927	1.000
2	1.000	0.927	0.938
	1.375	0.925	0.938
2.5	1.000	0.927	0.938
	1.750	0.928	0.938
	1.375	0.925	0.938
3.25	1.375	1.175	1.125
	2.000	0.862	1.125
	1.750	1.178	1.125
4	1.750	1.178	1.063
	2.500	0.869	1.063
	2.000	0.862	1.063
5	2.000	0.862	0.938
	3.500	0.869	0.938
	2.500	0.869	0.938
	3.000	0.869	0.938
6	2.500	1.119	1.313
	4.000	1.119	1.313
	3.000	1.119	1.313
	3.500	0.869	1.313
7	3.000	1.619	1.750
	5.000	1.496	1.750
	3.500	1.619	1.750
	4.000	1.119	1.750
	4.500	1.496	1.750
8	3.500	1.869	1.813
	5.500	1.745	1.813
	4.000	1.119	1.813
	4.500	1.496	1.813
	5.000	1.496	1.813



Cushion Energy Absorption Capacity Data

The cushion energy absorption data shown below is based on the maximum fatigue-free pressure developed in the tube. For application with a life cycle of less than 10^6 cycles, greater

energy absorption figures can be applied. Please consult the factory if further information is required.

Head End

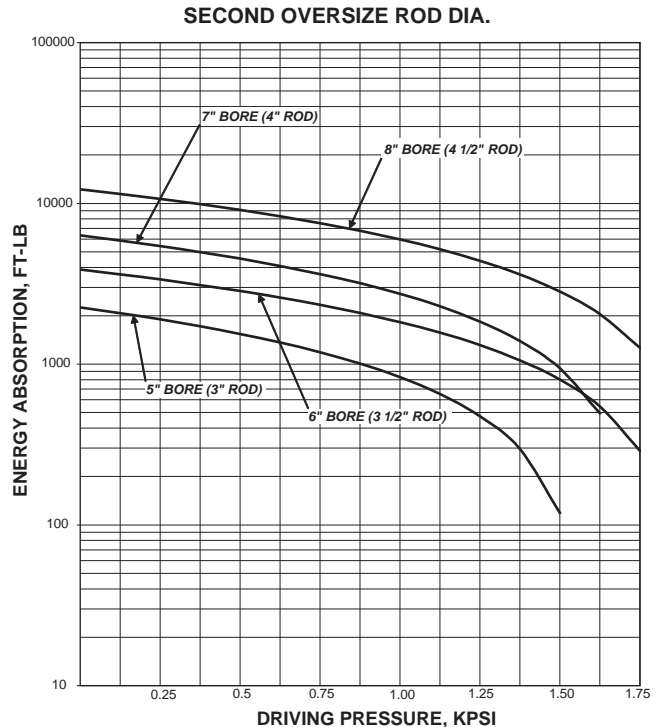
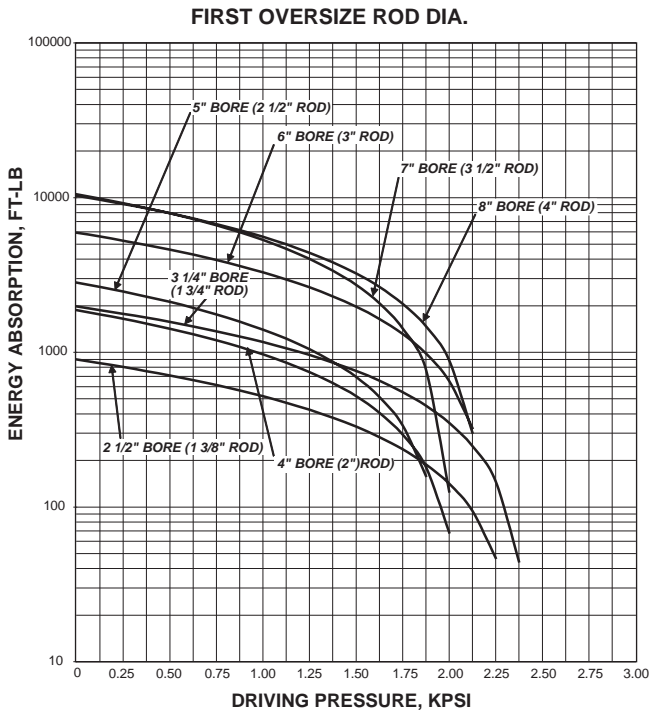
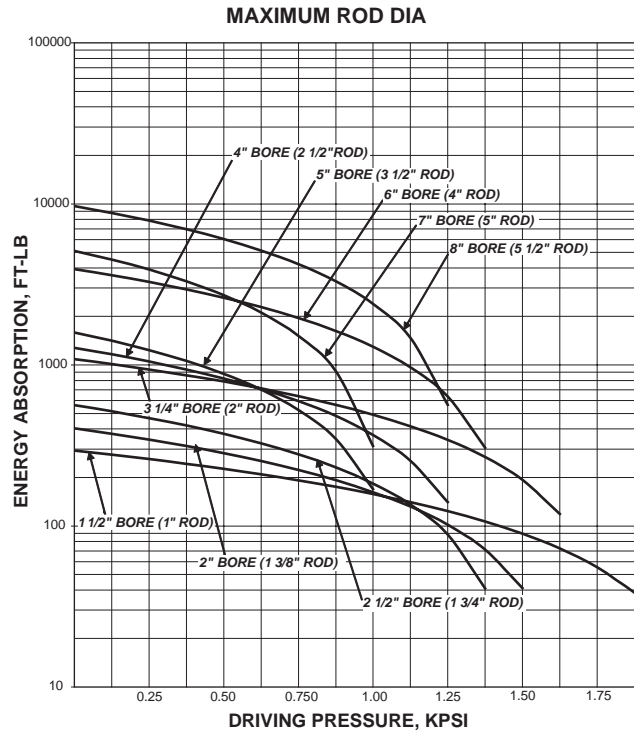
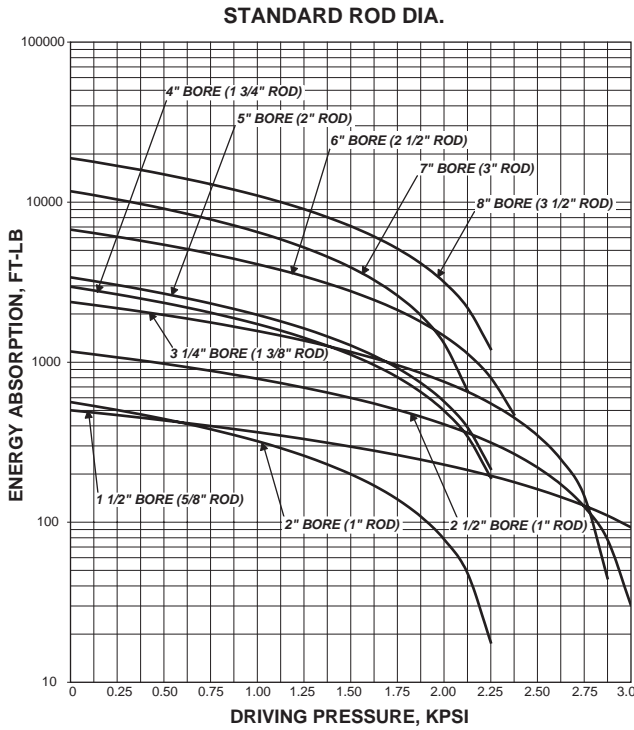

Cushion Energy Absorption Capacity Data

The cushion energy absorption data shown below is based on the maximum fatigue-free pressure developed in the tube. For application with a life cycle of less than 10⁶ cycles, greater

energy absorption figures can be applied. Please consult the factory if further information is required.

Head End

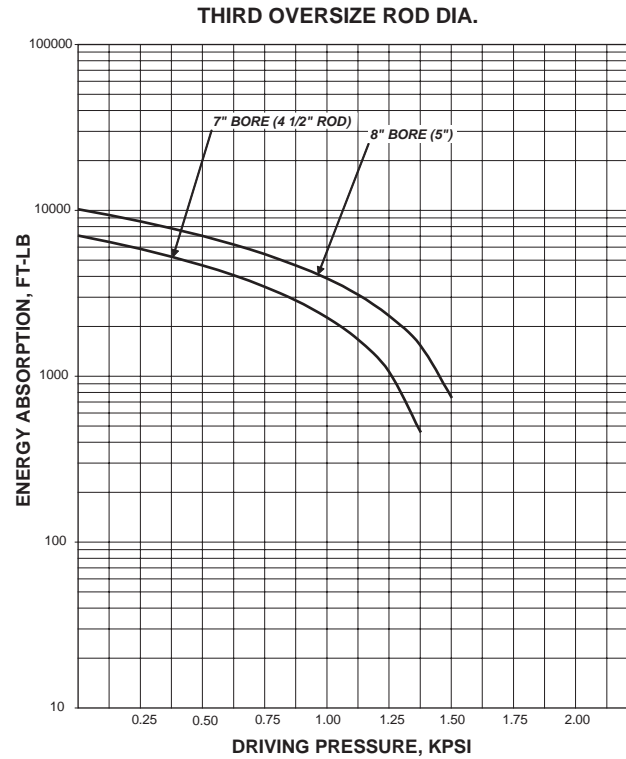

C

Cushion Energy Absorption Capacity Data

The cushion energy absorption data shown below is based on the maximum fatigue-free pressure developed in the tube. For application with a life cycle of less than 10⁶ cycles, greater

energy absorption figures can be applied. Please consult the factory if further information is required.

Cap End

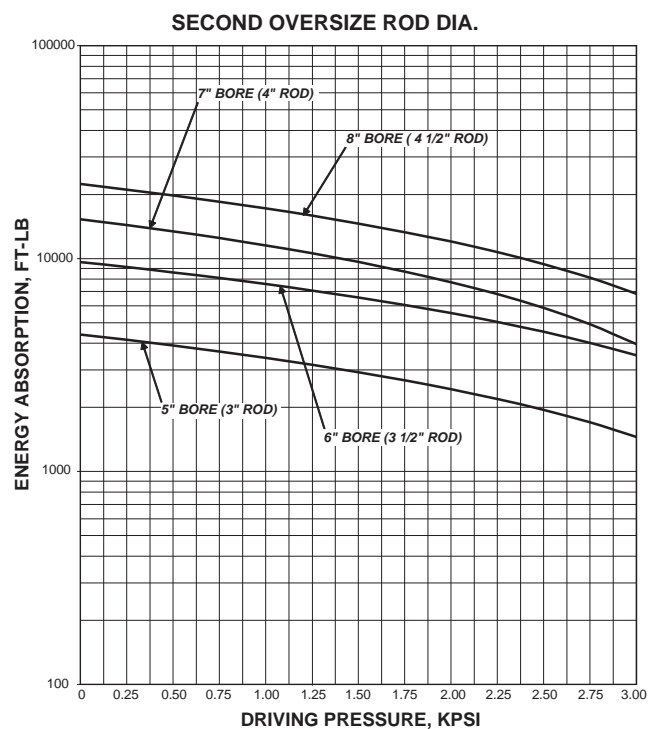
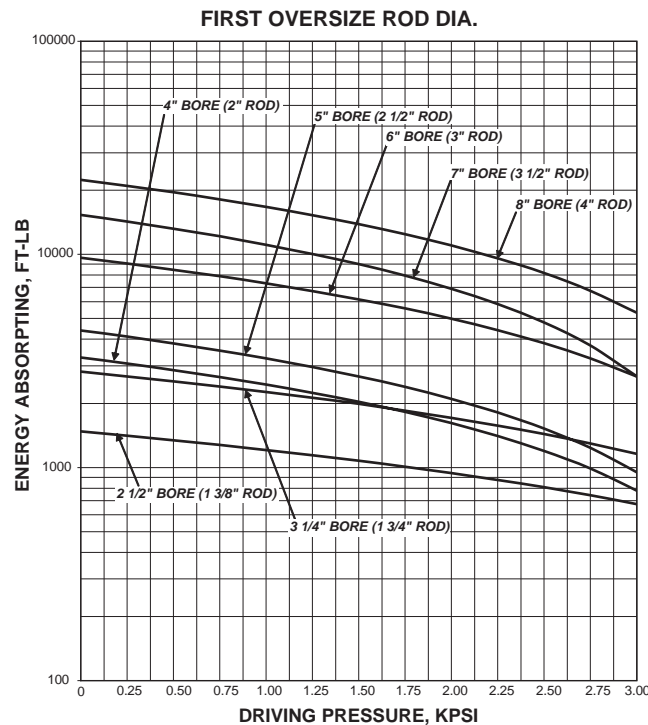
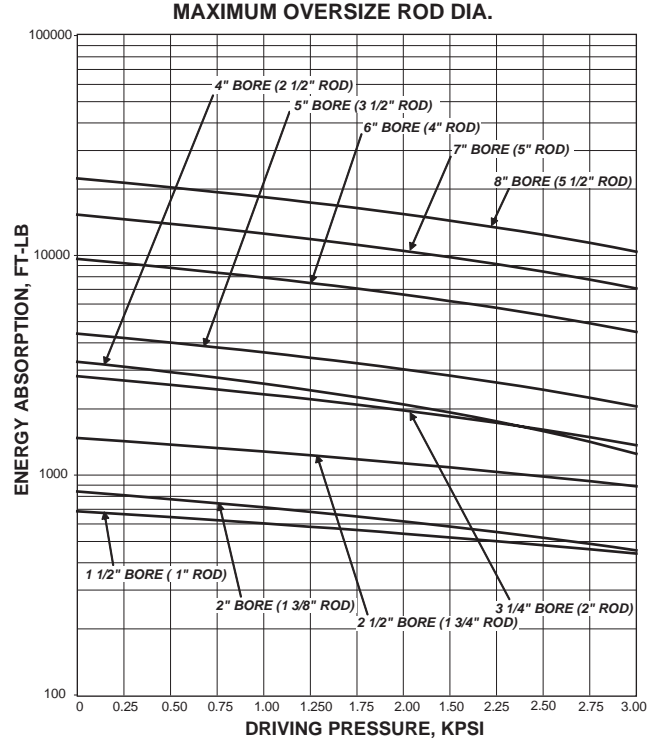
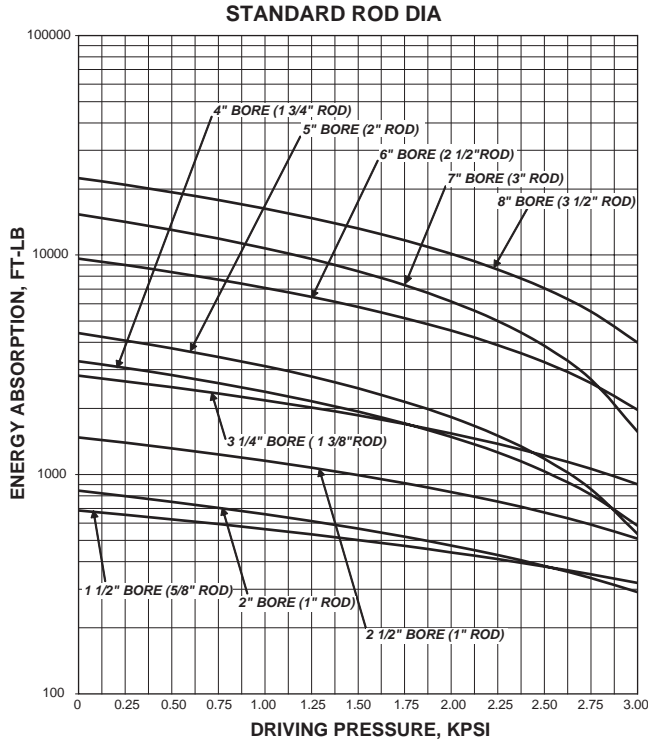

Cushion Energy Absorption Capacity Data

The cushion energy absorption data shown below is based on the maximum fatigue-free pressure developed in the tube. For application with a life cycle of less than 10^6 cycles, greater

energy absorption figures can be applied. Please consult the factory if further information is required.

Cap End

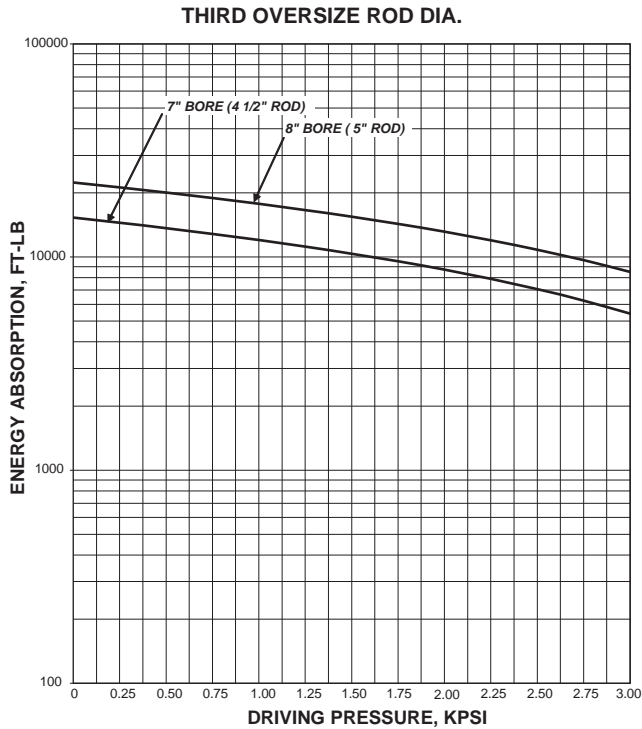

C

NOTES

Acceleration and Deceleration Force Determination

The uniform acceleration force factor chart and the accompanying formula can be used to rapidly determine the forces required to accelerate and decelerate a cylinder load. To determine these forces, the following factors must be known: total weight to be moved, maximum piston speed, distance available to start or stop the weight (load), direction

of movement, i.e. horizontal or vertical, and load friction. By use of the known factors and the "g" factor from chart, the force necessary to accelerate or decelerate a cylinder load may be found by solving the formula (as shown in chart below) application to a given set of conditions.

Nomenclature

- V = Velocity in feet per minute
- S = Distance in inches
- F = Force in lbs.
- W = Weight of load in pounds
- g = Force factor
- f = Friction of load on machine ways in pounds

To determine the force factor "g" from the chart, locate the intersection of the maximum piston velocity line and the line representing the available distance. Project downward to locate "g" on the horizontal axis. To calculate the "g" factor for distances and velocities exceeding those shown on the chart, the following formula can be used:

$$g = v^2/s \times .0000517$$

Example: Horizontal motion of a free moving 6,000 lb. load is required with a distance of 1/2" to a maximum speed of 120 feet per minute.

Formula (1) $F = Wg$ should be used.

$$F = 6,000 \text{ pounds} \times 1.50 \text{ (from chart)} = 9,000 \text{ pounds}$$

Assuming a maximum available pump pressure of 1,000 p.s.i., a 4" bore cylinder should be selected, operating on push stroke at approximately 750 p.s.i. pressure at the cylinder to allow for pressure losses from the pump to the cylinder.

Assume the same load to be sliding on ways with a coefficient of friction of 0.15. The resultant friction load would be 6,000 x 0.15 = 900 lbs.

Formula (2) $F = Wg + f$ should be used.

$$F = 6,000 \text{ lbs.} \times 1.5 \text{ (from chart)} + 900 = 9,900 \text{ lbs.}$$

Again allowing 750 p.s.i. pressure at the cylinder, a 5" bore cylinder is indicated.

Example: Horizontal deceleration of a 5000 pound load is required by using a 1" long cushion in a 5" bore cylinder having a 1 3/4" diameter piston rod. Cylinder bore area (19.64 Sq. In.) minus the rod area results in a minor area of 17.23 Sq. In. at head end of cylinder. A pump delivering 500 p.s.i. at the cylinder is used to push the load at 120 feet per minute. Friction coefficient is 0.15 or 750 lbs.

In this example, the total deceleration force is the sum of the force needed to decelerate the 5,000 pounds load, and the force required to counteract the thrust produced by the pump.

- W = Load in lbs. = 5000
- S = Deceleration distance in inches = 1"
- V = Maximum piston speed in feet per minute = 120
- g = .74 (from chart)
- f = 750 pounds

Use formula (3) $F = Wg - f$

$$(F = Wg - f) = (F = 5000 \times .74 - 750) = 2,950 \text{ Pounds}$$

The pump is delivering 500 p.s.i. acting on the 19.64 Sq. In. piston area producing a force (F2) of 9820 pounds. This force must be included in our calculations. Thus $F + F2 = 2950 + 9820 = 12,770$ pounds total force to be decelerated.

The total deceleration force is developed by the fluid trapped between the piston and the head. The fluid pressure is equal to the force (12,770 pounds) divided by the minor area (17.23 Sq. In.) equals 741 p.s.i. This pressure should not exceed the non-shock rating of the cylinder.

Cushioning practice is to select a "g" factor between .2 and 1.5.

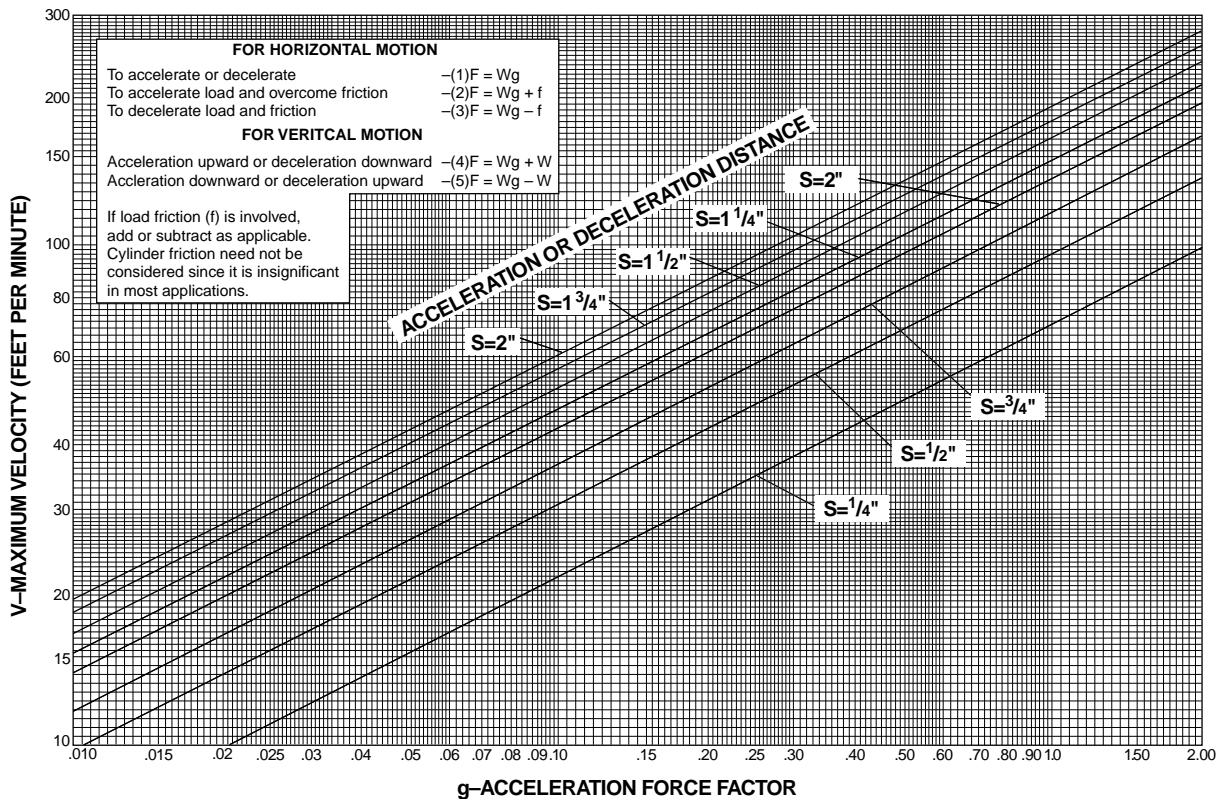

One of the factors involved in determining the speed of a hydraulic cylinder piston is fluid flow in connecting lines, generally measured in gallons per minute, introduced to, or expelled from, cap end cylinder port. (Due to piston rod displacement, the flow at head end port will be less than at cap end.) Fluid velocity, however, is measured in feet per second. In connecting lines this velocity should generally be limited to 15 feet per second to minimize fluid turbulence, pressure loss and hydraulic shock.

Piston speed for cylinders can be calculated from data shown in **table b-5**. The table shows fluid velocity flow for major cylinder

areas as well as for the net area at the rod end for cylinders 1" through 14" bore size.

If desired piston speed results in fluid flow in excess of 15 feet per second in connecting lines, consider the use of larger lines up to cylinder port, using either oversized ports or two ports per cap.

If heavy loads are involved or piston speeds are in excess of 20 feet per minute and the piston will make a full stroke, cushions are recommended. Cushions increase cylinder life and reduce undesirable noise.

Table b-5

Cylinder Bore (Inches)	Piston Rod		Cylinder Net Area (Sq. In.)	Fluid Displacement at 10 Ft. Per Min. Piston Velocity		Fluid Velocity (In Feet Per Second) Through Extra Heavy Pipe at 10 F.P.M. Piston Speed. For Series PH-2 Cylinders Standard Port Size is First to Left of Heavy Black Line.								
	Dia. (Inches)	Area (Sq. In.)		GPM	CFM	1/4	3/8	1/2	3/4	1	1 1/4	1 1/2	2	2 1/2
1	0	0	.785	.41	.054	1.82	.92	.56	.30	.183	.102	.074	.045	—
	1/2	.196	.589	.30	.041	1.33	.68	.41	.21	.134	.075	.055	.033	—
	5/8	.307	.478	.16	.033	.71	.36	.22	.12	.071	.040	.029	.017	—
1 1/2	0	.0	1.77	.92	.123	4.09	2.09	1.259	.680	.410	.230	.167	.100	—
	5/8	.307	1.46	.76	.101	3.38	1.73	1.040	.562	.338	.190	.138	.082	—
	1	.785	.98	.51	.068	2.27	1.16	.699	.378	.228	.128	.093	.055	—
2	0	0	3.14	1.63	.218	7.27	3.71	2.238	1.209	.728	.408	.296	.177	—
	5/8	.307	2.84	1.48	.197	6.56	3.35	2.019	1.091	.657	.368	.267	.160	—
	1	.785	2.36	1.23	.164	5.45	2.79	1.678	.907	.546	.306	.222	.133	—
2 1/2	0	0	4.91	2.55	.341	11.36	5.80	3.496	1.890	1.138	.638	.463	.277	—
	5/8	.307	4.60	2.39	.319	10.65	5.44	3.278	1.771	1.067	.598	.434	.260	—
	1	.785	4.12	2.14	.286	9.54	4.87	2.937	1.587	.956	.536	.389	.233	—
3 1/4	0	0	8.30	4.31	.576	19.20	9.81	5.909	3.193	1.923	1.078	.783	.468	—
	1	.785	7.51	3.90	.521	17.38	8.88	5.349	2.891	1.741	.976	.708	.424	—
	1 3/8	1.485	6.81	3.54	.473	15.77	8.05	4.851	2.622	1.579	.885	.642	.384	—
4	0	0	12.57	6.53	.872	29.09	14.85	8.95	4.84	2.91	1.63	1.19	.709	—
	1	.785	11.78	6.12	.818	27.27	13.93	8.39	4.54	2.73	1.53	1.11	.665	—
	1 3/8	1.485	11.08	5.76	.769	25.65	13.10	7.89	4.27	2.57	1.44	1.05	.625	—
5	0	0	19.64	10.20	1.363	45.45	23.21	13.99	7.56	4.55	2.55	1.85	1.108	—
	1	.785	18.85	9.79	1.308	43.64	22.28	13.43	7.26	4.37	2.45	1.78	1.064	—
	1 3/8	1.485	18.15	9.43	1.260	42.01	21.45	12.93	6.99	4.21	2.36	1.71	1.024	—
6	0	0	28.27	14.69	1.962	65.45	33.42	20.14	10.88	6.55	3.67	2.67	1.596	—
	1 3/8	1.485	26.79	13.92	1.859	62.01	31.67	19.08	10.31	6.21	3.48	2.53	1.512	—
	1 3/4	2.405	25.87	13.44	1.795	59.88	30.58	18.43	9.96	5.60	3.36	2.44	1.460	—
7	0	0	37.70	19.44	2.745	88.80	45.12	27.14	15.56	9.53	5.43	3.87	2.336	—
	1 3/4	2.405	36.17	18.77	2.632	85.41	43.59	26.26	14.99	9.17	5.27	3.71	2.272	—
	2	3.142	34.36	17.99	2.519	82.00	41.90	25.27	14.32	8.81	5.11	3.55	2.208	—
8	0	0	47.12	24.48	3.690	117.84	60.16	36.28	21.44	13.06	7.56	5.27	3.232	—
	1 3/4	2.405	45.37	23.61	3.577	114.43	58.41	35.30	20.77	12.70	7.40	5.11	3.068	—
	2	3.142	43.48	22.74	3.464	111.02	56.66	34.32	20.08	12.34	7.24	4.95	2.904	—
9	0	0	56.54	29.50	4.662	153.76	78.24	47.72	28.56	16.59	9.53	6.71	4.176	—
	1 3/4	2.405	54.59	28.53	4.549	150.35	76.49	46.74	27.87	16.23	9.37	6.55	4.012	—
	2	3.142	52.60	27.56	4.436	146.94	74.76	45.76	27.18	15.87	9.21	6.39	3.848	—
10	0	0	65.96	34.56	5.844	195.70	93.28	58.80	37.70	21.84	12.56	8.95	5.456	—
	1 3/4	2.405	63.81	33.59	5.731	192.29	91.55	57.82	37.01	21.48	12.40	8.79	5.292	—
	2	3.142	61.62	32.62	5.618	188.88	90.00	56.84	36.32	21.12	12.24	8.63	5.128	—
11	0	0	75.38	39.62	7.026	247.64	111.76	70.72	47.68	27.00	15.44	10.79	6.704	—
	1 3/4	2.405	73.03	38.55	6.913	244.23	110.03	69.74	47.00	26.64	15.28	10.63	6.540	—
	2	3.142	70.74	37.48	6.800	240.82	108.30	68.76	46.32	26.28	15.12	10.47	6.376	—
12	0	0	84.80	44.68	8.208	300.50	133.52	83.58	59.64	32.88	18.34	12.95	8.272	—
	1 3/4	2.405	82.35	43.51	8.095	297.09	131.79	82.60	59.00	32.52	18.18	12.79	8.108	—
	2	3.142	80.00	42.44	7.982	293.68	130.06	81.62	58.32	32.16	18.02	12.63	7.944	—
13	0	0	94.22	49.74	9.390	353.36	155.28	95.40	71.52	39.72	21.56	15.19	9.768	—
	1 3/4	2.405	91.57	48.57	9.277	350.00	153.55	94.42	70.80	39.36	21.40	15.03	9.604	—
	2	3.142	89.00	47.40	9.164	346.64	151.82	93.44	70.08	39.00	21.24	14.87	9.440	—
14	0	0	103.64	54.80	10.572	406.22	177.04	107.16	83.40	47.64	25.00	17.41	11.584	—
	1 3/4	2.405	100.89	53.63	10.459	402.86	175.31	106.18	82.72	47.28	24.84	17.25	11.420	—
	2	3.142	98.00	52.46	10.346	399.50	173.58	105.20	82.00	46.92	24.68	17.09	11.256	—

Table b-5 (cont.)

Cylinder Bore (Inches)	Piston Rod		Cylinder Net Area (Sq. In.)	Fluid Displacement at 10 Ft. Per Min. Piston Velocity		Fluid Velocity (In Feet Per Second) Through Extra Heavy Pipe at 10 F.P.M. Piston Speed. For Series PH-2 Cylinders Standard Port Size is first to Left of Heavy Black Line.								
	Dia. (Inches)	Area (Sq. In.)		GPM	CFM	1/4	3/8	1/2	3/4	1	1 1/4	1 1/2	2	2 1/2
7	0	0	38.49	20.00	2.671	89.1	45.5	27.41	14.81	8.92	5.00	3.63	2.17	—
	1 3/8	1.485	37.00	19.22	2.568	85.7	43.7	26.35	14.24	8.58	4.81	3.49	2.09	—
	1 3/4	2.405	36.08	18.74	2.504	83.5	42.7	25.70	13.89	8.36	4.69	3.40	2.04	—
	2	3.142	35.34	18.36	2.453	81.8	41.8	25.17	13.60	8.19	4.59	3.33	2.00	—
	2 1/2	4.909	33.58	17.44	2.330	77.7	39.7	23.92	12.92	7.78	4.36	3.17	1.90	—
	3	7.069	31.42	16.32	2.181	72.7	37.1	22.38	12.09	7.28	4.08	2.96	1.77	—
	3 1/2	9.621	28.86	14.99	2.003	66.8	34.1	20.56	11.11	6.69	3.75	2.72	1.63	—
	4	12.566	25.92	13.47	1.799	60.0	30.6	18.46	9.98	6.01	3.37	2.45	1.46	—
	4 1/2	15.904	22.58	11.73	1.567	52.3	26.7	16.08	8.69	5.23	2.93	2.12	1.28	—
5	19.635	18.85	9.79	1.308	43.6	22.3	13.43	7.26	4.37	2.45	1.78	1.06	—	
8	0	0	50.27	26.12	3.489	116.4	59.4	35.80	19.35	11.65	6.53	4.74	2.84	1.977
	1 3/8	1.485	48.78	25.34	3.385	112.9	57.7	34.74	18.78	11.31	6.34	4.60	2.75	1.918
	1 3/4	2.405	47.86	24.86	3.321	110.8	56.6	34.09	18.42	11.09	6.22	4.51	2.70	1.882
	2	3.142	47.12	24.48	3.270	109.1	55.7	33.56	18.14	10.92	6.12	4.45	2.66	1.853
	2 1/2	4.909	45.36	23.57	3.149	105.0	53.61	32.31	17.46	10.51	5.892	4.278	2.560	1.784
	3	7.069	43.20	22.44	2.998	100.0	51.06	30.77	16.63	10.01	5.612	4.074	2.438	1.699
	3 1/2	9.621	40.65	21.12	2.821	94.1	48.04	28.95	15.65	9.42	5.279	3.834	2.294	1.598
	4	12.566	37.70	19.59	2.616	87.3	44.56	26.85	14.51	8.74	4.897	3.556	2.128	1.483
	4 1/2	15.904	34.36	17.85	2.385	79.5	40.62	24.47	13.23	8.20	4.464	3.241	1.939	1.351
	5	19.635	30.63	15.91	2.126	70.9	36.21	21.82	11.79	7.10	3.979	2.889	1.729	1.205
5 1/2	23.758	26.51	13.77	1.840	61.4	31.33	18.88	10.20	6.15	3.444	2.500	1.496	1.043	
10	0	0	78.54	40.80	5.451	181.8	92.84	55.94	30.23	18.21	10.203	7.408	4.433	3.089
	1 3/4	2.405	76.14	39.56	5.284	176.2	89.99	54.23	29.31	17.65	9.890	7.181	4.297	2.994
	2	3.142	75.40	39.17	5.233	174.5	89.12	53.70	29.02	17.48	9.795	7.112	4.255	2.965
	2 1/2	4.909	73.63	38.25	5.110	170.4	87.03	52.44	28.34	17.07	9.565	6.945	4.156	2.896
	3	7.069	71.47	37.13	4.960	165.4	84.48	50.91	27.51	16.57	9.284	6.741	4.034	2.811
	3 1/2	9.621	68.92	35.80	4.783	159.5	81.47	49.09	26.53	15.98	8.953	6.501	3.890	2.710
	4	12.566	65.97	34.27	4.578	152.7	77.98	46.99	25.39	15.29	8.570	6.223	3.724	2.595
	4 1/2	15.904	62.64	32.54	4.347	145.0	74.04	44.61	24.11	14.52	8.137	5.908	3.535	2.463
	5	19.635	58.91	30.60	4.088	136.4	69.63	41.96	22.67	13.65	7.652	5.556	3.325	2.317
	5 1/2	23.758	54.78	28.46	3.802	126.8	64.75	39.02	21.09	12.70	7.116	5.167	3.092	2.154
	6	28.274	50.27	26.12	3.489	116.4	59.42	35.80	19.35	11.65	6.530	4.741	2.837	1.977
6 1/2	33.183	45.36	23.57	3.148	105.0	53.6	32.31	17.46	10.52	5.89	4.278	2.560	1.784	
7	38.485	40.06	20.81	2.780	92.7	47.4	28.53	15.42	9.29	5.20	3.778	2.261	1.575	
12	0	0	113.10	58.76	7.849	261.8	133.7	80.55	43.53	26.22	14.69	10.668	6.383	4.448
	2	3.142	109.96	57.12	7.631	254.5	130.0	78.32	42.32	25.49	14.28	10.371	6.206	4.324
	2 1/2	4.909	108.19	56.21	7.508	250.4	127.9	77.06	41.64	25.08	14.05	10.205	6.106	4.255
	3	7.069	106.03	55.08	7.359	245.4	125.3	75.52	40.81	24.58	13.77	10.001	5.984	4.170
	3 1/2	9.621	103.48	53.76	7.182	239.5	122.3	73.70	39.83	23.99	13.44	9.760	5.840	4.069
	4	12.566	100.53	52.23	6.977	232.7	118.8	71.60	38.70	23.30	13.06	9.482	5.674	3.954
	4 1/2	15.904	97.19	50.49	6.745	225.0	114.9	69.23	37.41	22.53	12.63	9.168	5.486	3.822
	5	19.635	93.46	48.55	6.486	216.4	110.5	66.57	35.98	21.67	12.14	8.816	5.275	3.676
	5 1/2	23.758	89.34	46.41	6.200	206.8	105.6	63.63	34.39	20.71	11.61	8.427	5.042	3.513
	6	28.274	84.82	44.06	5.887	196.4	100.3	60.42	32.65	19.66	11.02	8.001	4.787	3.336
	6 1/2	33.183	79.92	41.52	5.547	185.0	94.5	56.92	30.76	18.53	10.38	7.538	4.510	3.143
	7	38.485	74.61	38.77	5.179	172.7	88.2	53.14	28.72	17.30	9.69	7.038	4.211	2.934
	7 1/2	44.179	68.92	35.80	4.783	159.5	81.5	49.09	26.53	15.98	8.95	6.501	3.890	2.710
8	50.266	62.83	32.64	4.360	145.4	74.3	44.75	24.19	14.57	8.16	5.926	3.546	2.471	
8 1/2	56.745	56.35	29.27	3.911	130.5	66.6	40.14	21.69	13.06	7.32	5.315	3.181	2.216	
14	0	0	153.94	79.97	10.683	356.3	182.0	109.6	59.25	35.68	20.00	14.52	8.688	6.054
	2 1/2	4.909	149.03	77.42	10.343	345.0	176.2	106.2	57.36	34.55	19.36	14.06	8.411	5.861
	3	7.069	146.87	76.30	10.193	340.0	173.6	104.6	56.53	34.05	19.08	13.85	8.289	5.776
	3 1/2	9.621	144.32	74.97	10.016	334.1	170.6	102.8	55.55	33.45	18.75	13.61	8.145	5.676
	4	12.566	141.37	73.44	9.811	327.3	167.1	100.7	54.42	32.77	18.37	13.33	7.979	5.560
	4 1/2	15.904	138.03	71.71	9.579	319.5	163.2	98.3	53.13	32.00	17.93	13.02	7.791	5.428
	5	19.635	134.30	69.77	9.320	310.9	158.8	95.7	51.70	31.13	17.45	12.67	7.580	5.282
5 1/2	23.758	130.18	67.63	9.035	301.3	153.9	92.7	50.11	30.18	16.91	12.28	7.347	5.120	

C

Cushion ratings for **Air Cylinders Only** are described in **table b-7** and **graph b-3** below. To determine whether a cylinder will adequately stop a load without damage to the cylinder, the weight of the load (including the weight of the piston and the piston rod from **table b-6**) and the maximum speed of the piston rod must first be determined. Once these two factors are known, the **Kinetic Energy Graph** may be used. Enter the graph at its base for the value of weight determined, and project vertically to the required speed value. The point of intersection of these two lines will be the cushion rating number required for the application.

To determine the total load to be moved, the weight of the piston and rod must be included.

Total Weight = weight of the piston and non-stroke rod length (column 1) + weight of the rod per inch of stroke x the inches of stroke (Column 2) + the load to be move.

Weight Table

Bore Dia.	Column 1 Basic Wgt. (lbs.) for Piston & Non-Stroke Rod	Rod Dia.	Column 2 Basic Wgt. (lbs.) for 1" Stroke
1 1/2	1.5	5/8	.087
2	3.0	1	.223
2 1/2	5.4	1 3/8	.421
3 1/4	8.3	1 3/4	.682
4	14.2	2	.89
5	29.0	2 1/2	1.39
6	41.0	3	2.0
8	89.0	3 1/2	2.73
10	115.0	4	3.56
12	161.0	5	5.56
14	207.0	5 1/2	6.73

Table b-6

Example: a 3 1/4" bore cylinder, having a 1" diameter rod and 25" stroke; load to be moved is 85 pounds. Total load to be moved is then 8.3 lbs. + .223 lbs./in. x 25 in. + 85 lbs. or a total of 99 lbs.

Kinetic Energy Graph – Air Cylinders

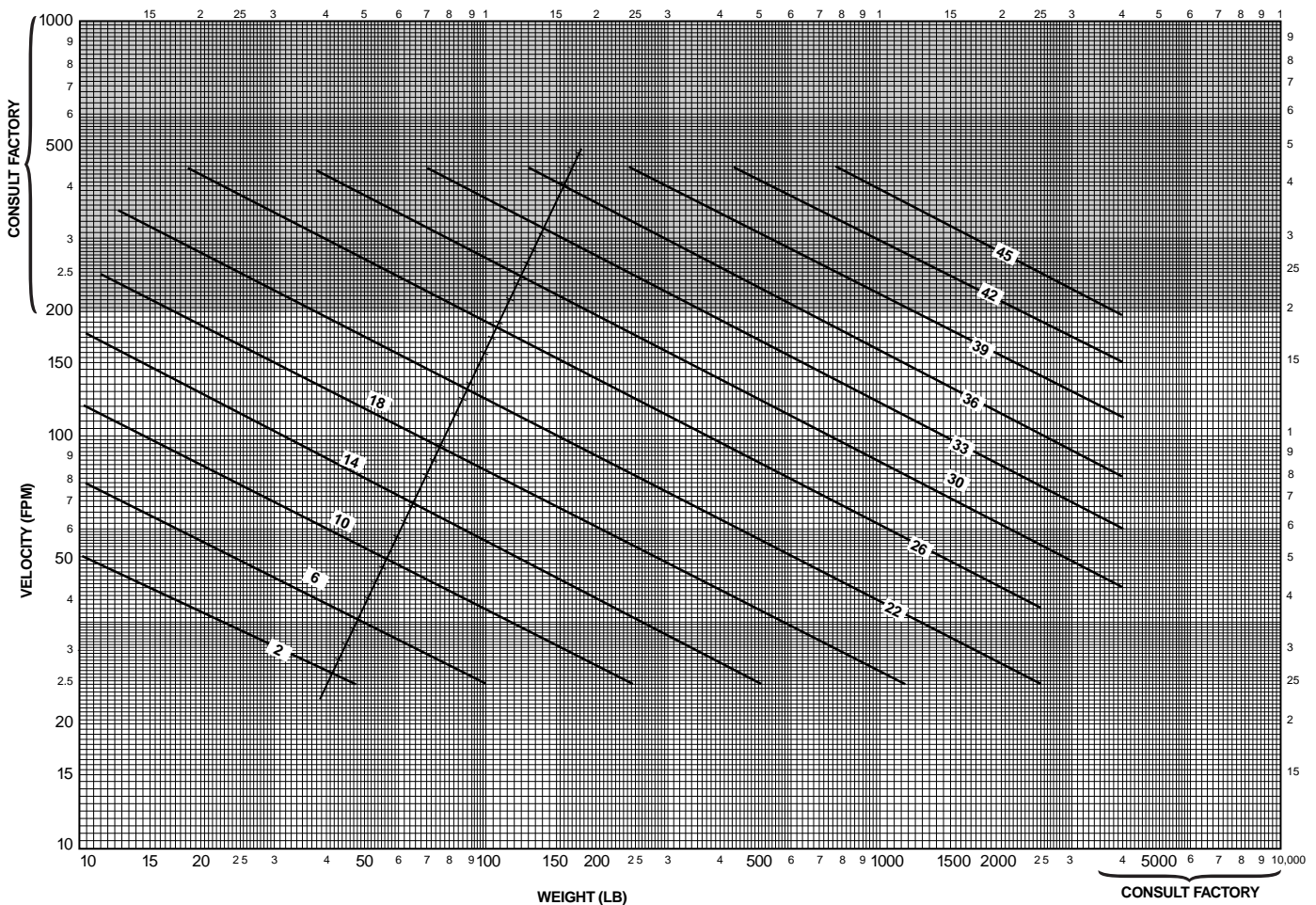

Graph b-3

Now refer to **table b-7** below and find the cushion ratings, using bore size and rod diameter of the cylinder selected. If a simple circuit is used, with no meter out or speed control, use the “no back pressure, Column A” values. If a meter out or speed control is to be used, use the back pressure column values. If the cushion rating found in **table b-7, below**, is **greater** than the number determined in **graph**

b-3, then the cylinder will stop the load adequately. If the cushion rating in **table b-7** is **smaller** than the number found in **graph b-3**, then a larger bore cylinder should be used. In those applications where back pressures exist in the exhaust lines, it is possible to exceed the cushion ratings shown in **table b-7**. In these cases, consult the factory and advise the amount of back pressure.

Air Cylinder Cushion Ratings Table

Bore Dia.	Rod Dia.	Rating With No Back Pressure	Rating With Back Pressure	Bore Dia.	Rod Dia.	Rating With No Back Pressure	Rating With Back Pressure
1 1/2	Cap End	12	17	7	3	24	30
	5/8	8	14		3 1/2	24	30
	1	3	8		4	23	29
2	Cap End	14	20		4 1/2	22	28
	5/8	12	18		5	21	27
	1	9	15		Cap End	29	35
	1 3/8	6	11		1 3/8	29	35
2 1/2	Cap End	17	23		1 3/4	29	34
	5/8	14	20		2	27	33
	1	14	19		2 1/2	26	32
	1 3/8	12	18	3	26	32	
	1 3/4	8	13	3 1/2	26	32	
3 1/4	Cap End	21	26	4	25	31	
	1	18	24	5	23	29	
	1 3/8	17	23	5 1/2	22	28	
	1 3/4	16	22	Cap End	33	39	
	2	13	19	1 3/4	32	38	
4	Cap End	23	28	2	31	37	
	1	20	27	2 1/2	31	36	
	1 3/8	20	26	3	30	36	
	1 3/4	19	25	3 1/2	30	36	
	2	17	23	4	30	36	
	2 1/2	17	22	5	28	34	
5	Cap End	26	31	5 1/2	27	33	
	1	23	28	Cap End	35	41	
	1 3/8	23	28	2	33	39	
	1 3/4	22	28	2 1/2	33	38	
	2	20	26	3	33	38	
	2 1/2	19	25	3 1/2	32	38	
	3	18	24	4	32	38	
6	3 1/2	15	20	5	31	36	
	Cap End	26	31	5 1/2	31	36	
	1 3/8	26	31	Cap End	38	43	
	1 3/4	26	31	2 1/2	37	42	
	2	24	29	3	36	42	
	2 1/2	24	29	3 1/2	36	41	
	3	22	28	4	36	41	
	3 1/2	21	27	5	35	40	
7	4	20	26	5 1/2	34	40	
	Cap End	28	33				
	1 3/8	28	33				
	1 3/4	28	33				
	2	26	31				

Table b-7

Air Requirement Per Inch of Cylinder Stroke

The amount of air required to operate a cylinder is determined from the volume of the cylinder and its cycle in strokes per minute. This may be determined by use of the following formulae which apply to a single-acting cylinder.

$$V = \frac{3.1416 L D^2}{4} \quad C = \frac{fV}{1728}$$

Where: V = Cylinder volume, cu. in.
 L = Cylinder stroke length, in.
 D = Internal diameter of cylinder in.
 C = Air required, cfm
 f = Number of strokes per minute

The air requirements for a double-acting cylinder is almost double that of a single-acting cylinder, except for the volume of the piston rod.



The air flow requirements of a cylinder in terms of cfm should not be confused with compressor ratings which are given in terms of free air. If compressor capacity is involved in the consideration of cylinder air requirements it will be necessary to convert cfm values to free air values. This relationship varies for different gauge pressures.

Thrust (pounds) = operating pressure x area of cylinder bore.

Note: That on the "out" stroke the air pressure is working on the entire piston area but on the "in" stroke the air pressure works on the piston area less the rod area.

Graph b-4 and **b-5** offer a simple means to select pneumatic components for dynamic cylinder applications. It is only necessary to know the force required, the desired speed and the pressure which can be maintained

at the inlet to the F-R-L "Combo." The graphs assume average conditions relative to air line sizes, system layout, friction, etc. At higher speeds, consider appropriate cushioning of cylinders.

The general procedure to follow when using these graphs is:

1. Select the appropriate graph depending upon the pressure which can be maintained to the system – **graph b-4** for 100 psig and **graph b-5** for 80 psig.
2. Determine appropriate cylinder bore. Values underneath the diagonal cylinder bore lines indicate the maximum recommended dynamic thrust developed while the cylinder is in motion. The data in the table at the bottom of each graph indicates available static force applications in which clamping force is a prime consideration in determining cylinder bore.

THIS GRAPH IS DETERMINED BY HAVING 100 PSIG AVAILABLE UNDER FLOWING CONDITIONS.

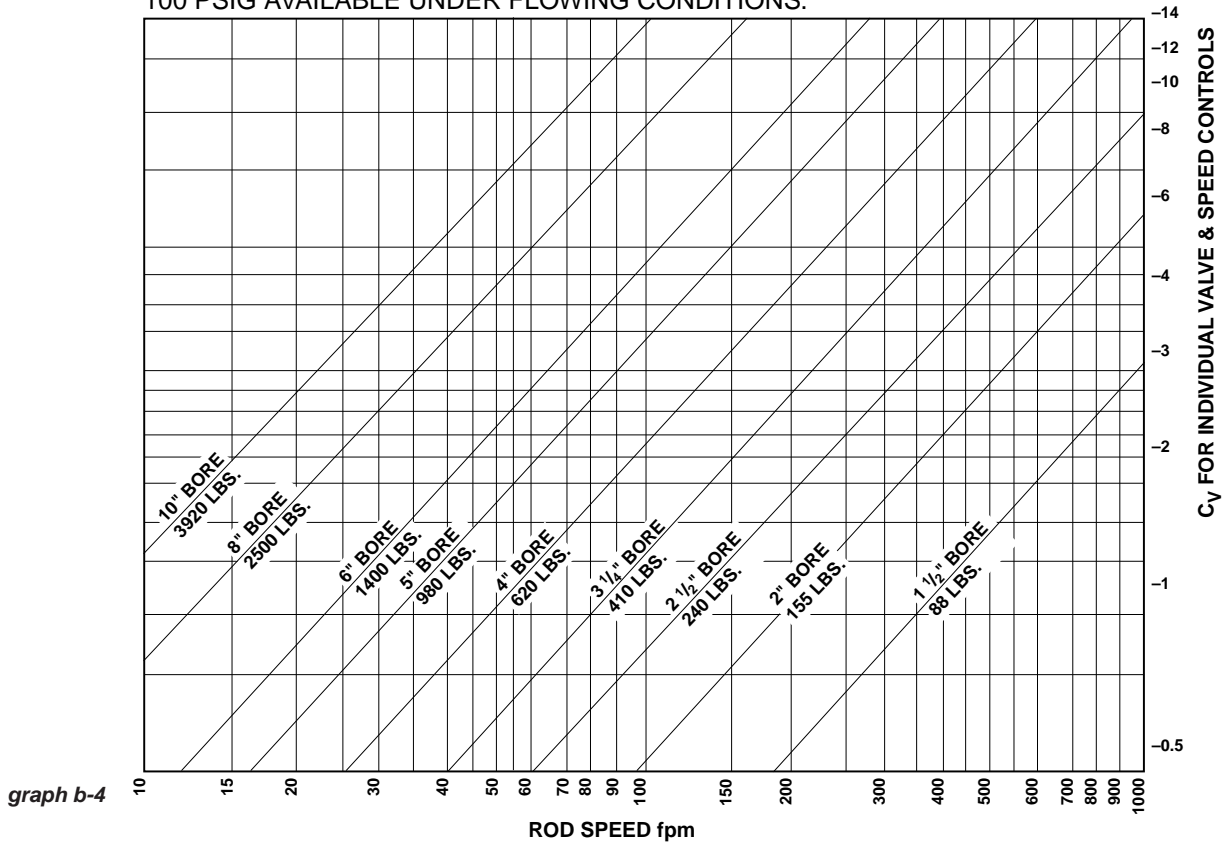

**Table b-8
Thrust Developed**

BORE SIZE	1 1/2"	2"	2 1/2"	3 1/4"	4"	5"	6"	8"	10"
DYNAMIC THRUST (lbs.)	88	155	240	410	620	980	1400	2500	3920
STATIC THRUST (lbs.)	177	314	491	830	1250	1960	2820	5020	7850

3. Read upward on appropriate rod speed line to intersection with diagonal cylinder bore line. Read right from intersection point to determine the required C_v of the valve and the speed controls. Both the valve and speed controls must have this C_v .

The following examples illustrate use of the graphs:

Example 1: Assume it is necessary to raise a 900-pound load 24 inches in two seconds. With 100 psig maintained at the inlet to the F-R-L, use **graph b-4**. The 5-inch bore cylinder is capable of developing the required thrust while in motion. Since 24 inches in two seconds is equal to 60 fpm, read upward on the 60 fpm line to the intersection of the 5-inch bore diagonal line. Reading to the right indicates that the required valve and speed controls must each have a C_v of over 1.9.

Example 2: Assume similar conditions to Example 1 except that only 80- psig will be available under flowing conditions. Using **graph b-5**, a 6-inch bore cylinder is indicated. Read upward on the 60 fpm line to the intersection point. Interpolation of the right-hand scale indicates a required valve and speed control C_v of over 2.8.

Example 3: Assume similar conditions to Example 1 except that the load is being moved in a horizontal plane with a coefficient of sliding friction of 0.2. Only a 180-pound thrust is now required (900 lb. x 0.2). Consult **graph b-4**. The 2-1/2 inch bore cylinder will develop sufficient thrust, and at 60 fpm requires a valve and speed control C_v of about 0.5.

THIS GRAPH IS DETERMINED BY HAVING 80 PSIG AVAILABLE UNDER FLOWING CONDITIONS.

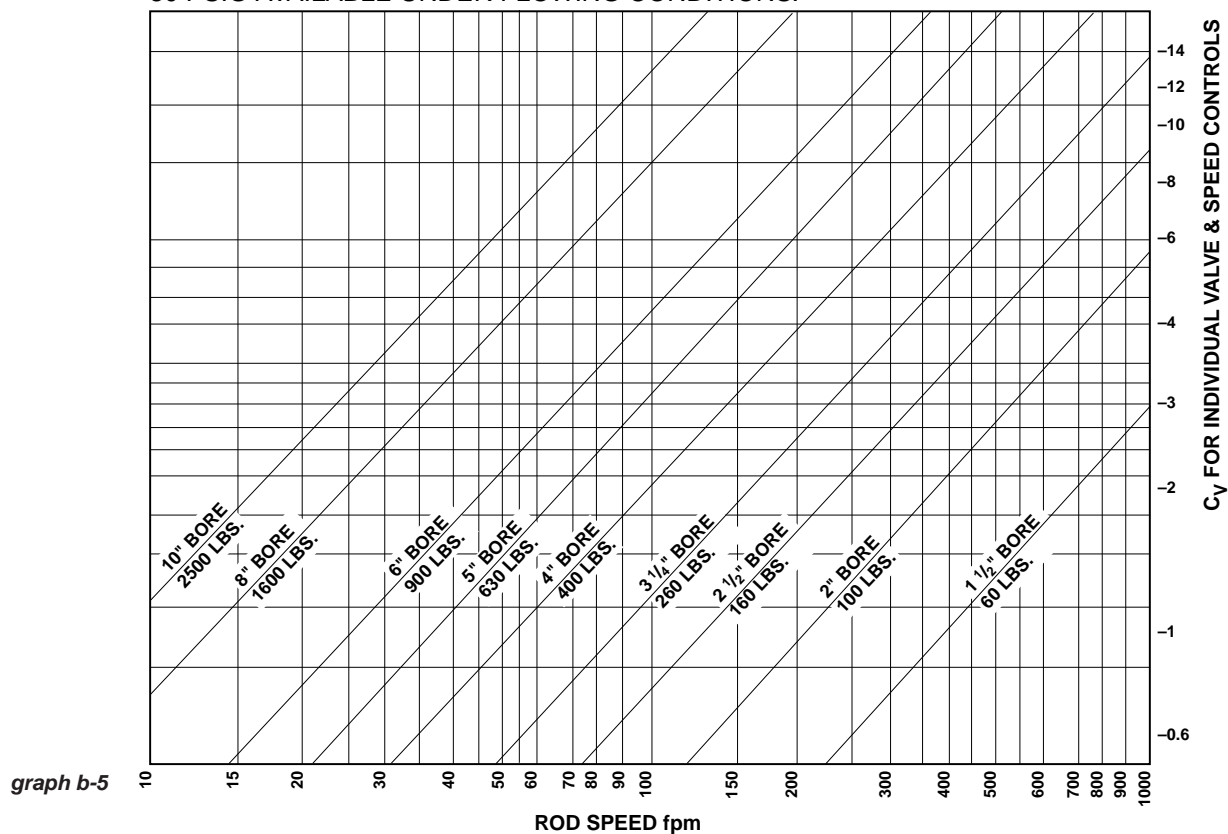

Table b-9
Thrust Developed

BORE SIZE	1 1/2	2	2 1/2	3 1/4	4	5	6	8	10
DYNAMIC THRUST (lbs.)	60	100	160	260	400	630	900	1600	2500
STATIC THRUST (lbs.)	141	251	393	663	1000	1570	2260	4010	6280



Modifications: The following modifications can be supplied on most Schrader Bellows cylinders. For specific availability see Modification Chart.

Metallic Rod Wiper

When specified metallic rod wipers can be supplied instead of the standard synthetic rubber wiperseal. Recommended in applications where contaminants tend to cling to the extended piston rod and would damage the synthetic rubber wiperseal. Installation of metallic rod wiper does not affect cylinder dimensions. It is available at extra cost.

Crown Wiper™ for Series PH-2 and 7" & 8" bore PH-3

For environments that contain fine abrasive particulate specify the Crown Wiper option. The Crown Wiper is a proven superior alternative to piston rod end boots or metallic wipers that can ingest particulate. It has a sharp leading edge to effectively clean the piston rod and a beveled shape to prevent contaminant intrusion by channeling it away from the gland. It also acts as a secondary seal to wipe clean any oil film adhering to the rod on the extend stroke.

Standard Crown Wiper material for Seal Class 1 and 2 service is durable polyurethane. Optional FKM material is available for Class 5 service. The Crown Wiper requires a unique gland but does not change cylinder mounting dimensions

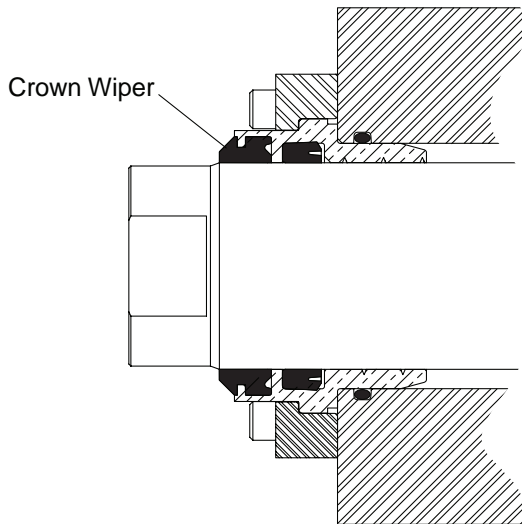

Air Bleeds

In most hydraulic circuits, cylinders are considered self-bleeding when cycled full stroke. If air bleeds are required and specified, 1/8" NPTF Air Bleed Ports for venting air can be provided at both ends of the cylinder body, or on the head or cap. To order, specify "Bleed Port", and indicate position desired.

Rod End Boots

Cylinders have a hardened bearing surface on the piston rod to resist external damage, and are equipped with the high efficiency "Wiperseal" to remove external dust and dirt. Exposed piston rods that are subjected to contaminants with air hardening properties, such as paint, should be protected. In such applications, the use of a collapsing cover should be considered. This is commonly referred to as a "boot". Calculate the longer rod end required to accommodate the collapsed length of the boot from the following data.

LF	.13	.13	.13	.13	.13	.13	.13	.10	.10	.10	.10	.10
OD	2 1/4	2 1/4	2 5/8	3	3 3/8	3 3/4	4 3/8	5 1/8	5 5/8	6 1/4	7	7 1/2
RD	1/2	5/8	1	1 3/8	1 3/4	2	2 1/2	3	3 1/2	4	5	5 1/2

To determine extra length of piston rod required to accommodate boot, calculate
 $BL = \text{Stroke} \times LF + 1\frac{1}{8}"$
 $BL + \text{Std. LA} = \text{length of piston rod to extend beyond the retainer.}$

NOTE: Check all Boot O.D's against std. "E" dimension from catalog. This may be critical on footmounted cylinders.

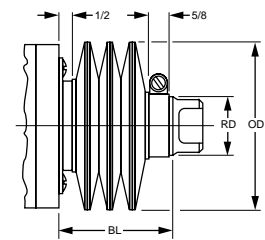

Tandem Cylinders

A tandem cylinder is made up of two cylinders mounted in line with pistons connected by a common piston rod and rod seals installed between the cylinders to permit double acting operation of each. Tandem cylinders allow increased output force when mounting width or height are restricted.

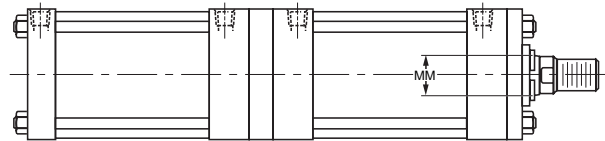

Reduced operating pressure is required for this construction. Please contact the factory.

Duplex Cylinders

A duplex cylinder is made up of two cylinders mounted in line with pistons not connected and with rod seals installed between the cylinders to permit double acting operation of each. Cylinders may be mounted with piston rod to piston (as shown) or back to back and are generally used to provide three position operation.

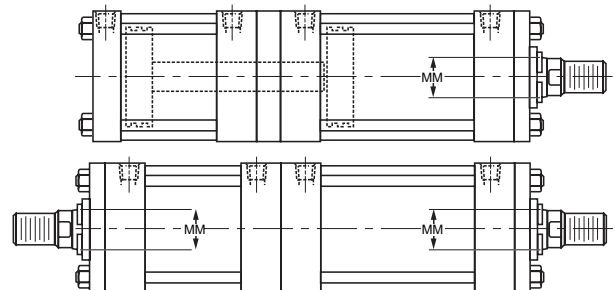

Reduced operating pressure is required for this construction. Please contact the factory.

The weights shown in Tables A and B are for Schrader Bellows PA-2, PH-2, PL-2, PH-3 Series (7" & 8") and PN cylinders with various piston rod diameters. To determine the net weight of a cylinder, first select the proper basic weight for zero stroke, then calculate the weight of the cylinder stroke and add the result to the basic weight. For extra rod

extension, use piston rod weights per inch shown in Table C. Weights of cylinders with intermediate rods may be estimated from table below by taking the difference between the piston rod weights per inch and adding it to the Code 1 weight for the cylinder bore size involved.

Table A Cylinder Weights, in pounds, for PH-2, PH-3 Series (7" & 8") hydraulic cylinders

Bore Size	Rod Dia.	Rod Code	Single Rod Cylinders Basic Wt. Zero Stroke		Add Per Inch of Stroke	Double Rod Cylinders Basic Wt. Zero Stroke		Add Per Inch of Stroke
			MF1, MF2, MF5, MF6, MS4 MX0, MX1, MX2, MX3	ME5, ME6, MP1, MS2, MT1, MT2, MT4		MDF1, MDF5, MDS4 MDX0, MDX1, MDX3	MDE5, MDS2 MDT1, MDT4	
1 1/2"	5/8"	1	7.8	9.0	.5	9.7	10.8	.6
	1"	2	8.4	9.3	.6	9.1	10.7	.8
2"	1"	1	11.6	13.2	.8	14.6	16.8	1.0
	1 3/8"	2	13.5	17.1	1.0	19.4	20.6	1.4
2 1/2"	1"	1	17.0	19.5	1.1	21.0	24.5	1.3
	1 3/4"	2	22.5	25.5	1.5	27.0	30.0	2.2
3 1/4"	1 3/8"	1	32.0	41.0	1.8	43.0	52.0	2.2
	2"	2	37.0	46.0	2.2	48.0	57.0	3.1
4"	1 3/4"	1	48.0	53.0	2.5	59.0	63.0	3.2
	2 1/2"	2	52.0	58.0	3.2	92.0	97.0	4.6
5"	2"	1	76.0	82.0	3.4	96.0	102.0	4.8
	3 1/2"	2	88.0	86.0	5.2	117.0	123.0	7.9
6"	2 1/2"	1	125.0	133.0	5.2	153.0	159.0	6.6
	4"	2	133.0	140.0	7.3	182.0	190.0	10.9
7"	3"	1	233.0	242.0	6.7	320.0	339.0	8.7
	5"	2	240.0	253.0	10.3	341.0	360.0	15.9
8"	3 1/2"	1	262.0	276.0	9.0	323.0	331.0	11.7
	5 1/2"	2	300.0	309.0	13.0	390.0	411.0	19.7

Table B Cylinder Weights, in pounds, for PA-2, PN, PL-2 Series cylinders

Bore Size	Rod Dia.	Single Rod Cylinders Basic Wt. Zero Stroke		Add Per Inch of Stroke	Double Rod Cylinders Basic Wt. Zero Stroke		Add Per Inch of Stroke
		MF1, MF2, MS4 MX0, MX1, MX2, MX3	MF5, MF6, MP1, MS2 MT1, MT2, MT4		MDF1, MDS4 MDX0, MDX1, MDX3	MDF5, MDS2 MDT1, MDT4	
1"	1/2"	2.5	2.9	.20	4.7	5.5	.40
	5/8"	2.6	3.0	.23	4.9	5.7	.46
1 1/2"	5/8"	3.7	4.3	.3	4.2	4.8	.6
	1"	4.5	5.1	.4	5.8	6.7	.8
2"	5/8"	6.5	6.9	.5	8.2	8.6	1.0
	1"	7.0	7.5	.63	9.0	9.5	1.3
2 1/2"	1 3/8"	8.5	8.9	.8	11.2	11.6	1.6
	5/8"	9.0	9.7	.6	11.4	12.1	1.2
2 1/2"	1"	9.5	10.0	.73	12.0	12.5	1.5
	1 3/4"	13.2	13.6	1.1	19.8	20.5	2.2
3 1/4"	1"	16.5	17.5	.8	22.0	23.0	1.6
	1 3/8"	17.0	18.0	1.0	22.5	23.5	2.0
4"	2"	27.0	28.0	1.4	43.0	44.0	2.8
	1"	26.0	31.0	1.0	33.0	38.0	2.0
4"	1 3/8"	26.5	31.5	1.2	33.5	38.5	2.5
	2 1/2"	36.0	42.0	2.0	53.0	58.0	4.0
5"	1"	39.0	46.0	1.1	48.0	55.0	2.2
	1 3/8"	39.5	46.5	1.3	48.5	55.5	2.6
5"	3 1/2"	63.0	66.0	3.6	96.0	103.0	7.2
	1 3/8"	68.0	77.0	1.5	80.0	89.0	3.0
6"	4"	100.0	102.0	4.5	144.0	153.0	9.0
	1 3/8"	80.0	85.0	2.0	92.0	97.0	4.0
7"	2"	82.0	87.0	3.5	96.0	101.0	7.0
	1 3/8"	94.0	99.0	2.0	108.0	113.0	4.0
8"	5 1/2"	168.0	172.0	8.0	256.0	261.0	16.0
	1 3/4"	182.0	188.0	2.5	178.0	184.0	5.0
10"	5 1/2"	258.0	264.0	8.5	330.0	335.0	17.0
	2"	274.0	282.0	3.5	270.0	280.0	7.0
12"	5 1/2"	350.0	358.0	9.5	420.0	430.0	19.0
	2 1/2"	435.0	448.0	4.5	440.0	655.0	9.0
14"	5 1/2"	510.0	519.0	10.0	490.0	705.0	20.0

Table C

Rod Dia.	Piston Rod Wt. Per Inch	Rod Dia.	Piston Rod Wt. Per Inch	Rod Dia.	Piston Rod Wt. Per Inch
5/8"	.09	2"	.89	4"	3.56
1"	.22	2 1/2"	1.40	4 1/2"	4.51
1 3/8"	.42	3"	2.00	5"	5.56
1 3/4"	.68	3 1/2"	2.72	5 1/2"	6.72

Piston Rod — Stroke Selection Chart

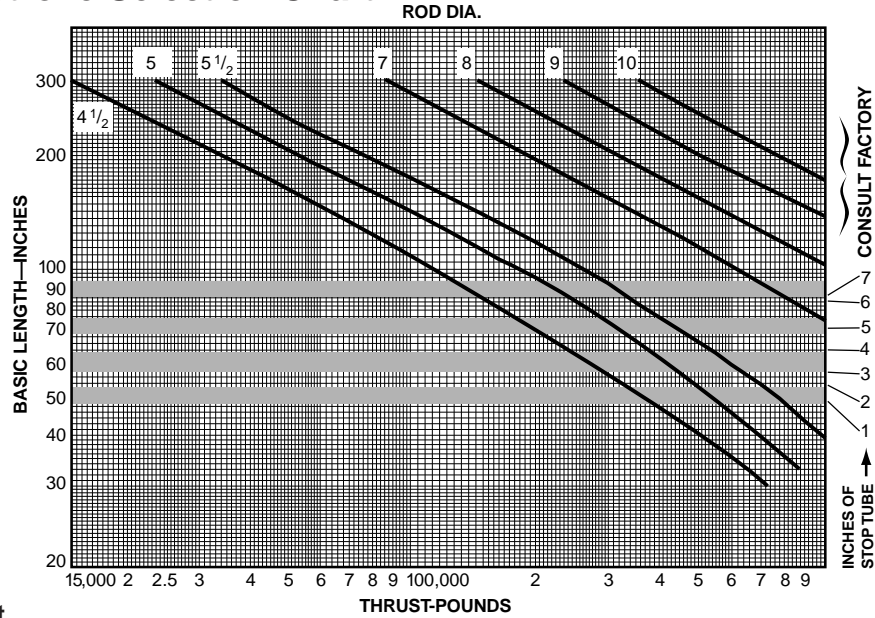

How to Use the Chart

The selection of a piston rod for thrust (push) conditions requires the following steps:

- Determine the type of cylinder mounting style and rod end connection to be used. Then consult the chart below and find the "stroke factor" that corresponds to the conditions used.
- Using this stroke factor, determine the "basic length" from the equation:

$$\text{Basic Length} = \frac{\text{Actual Stroke}}{\text{Stroke Factor}}$$

The graph is prepared for standard rod extensions beyond the face of the gland retainers. For rod extensions greater than standard, add the increase to the stroke in arriving at the "basic length."

- Find the load imposed for the thrust application by multiplying the full bore area of the cylinder by the system pressure.
- Enter the graph along the values of "basic length" and "thrust" as found above and note the point of intersection:
 - The correct piston rod size is read from the diagonally curved line labeled "Rod Diameter" next above the point of intersection.
 - The required length of stop tube is read from the right of the graph by following the shaded band in which the point of intersection lies.

- If required length of stop tube is in the region labeled "consult factory," submit the following information for an individual analysis:
 - Cylinder mounting style.
 - Rod end connection and method of guiding load.
 - Bore, required stroke, length of rod extension (Dim. "LA") if greater than standard.
 - Mounting position of cylinder. (Note: If at an angle or vertical, specify direction of piston rod.)
 - Operating pressure of cylinder if limited to less than standard pressure for cylinder selected.

Warning

Piston rods are not normally designed to absorb bending moments or loads which are perpendicular to the axis of piston rod motion. These additional loads can cause the piston rod end to fail. If these types of additional loads are expected to be imposed on the piston rods, their magnitude should be made known to our Engineering Department so they may be properly addressed. Additionally, cylinder users should always make sure that the piston rod is securely attached to the machine member.

Recommended Mounting Styles for Maximum Stroke and Thrust Loads	Rod End Connection	Case	Stroke Factor
Class 1 — Groups 1 or 3 Long stroke cylinders for thrust loads should be mounted using a heavy-duty mounting style at one end, firmly fixed and aligned to take the principal force. Additional mounting should be specified at the opposite end, which should be used for alignment and support. An intermediate support may also be desirable for long stroke cylinders mounted horizontally.	Fixed and Rigidly Guided	I	.50
	Pivoted and Rigidly Guided	II	.70
	Supported but not Rigidly Guided	III	2.00
Class 2 — Group 2 Heavy-Duty Style MT1 — Trunnion on Head	Pivoted and Rigidly Guided	IV	1.00
Heavy-Duty Style MT4 — Intermediate Trunnion	Pivoted and Rigidly Guided	V	1.50
Heavy-Duty Style MT2 — Trunnion on Cap or Style MP1 — Clevis on Cap	Pivoted and Rigidly Guided	VI	2.00

PH-3 Large Bore – Application Data

The proper application of a fluid power cylinder requires consideration of the operating pressure, the fluid medium, the mounting style, the length of stroke, the type of piston rod connection to the load, thrust or tension loading on the rod,

mounting attitude, the speed of stroke, and how the load in motion will be stopped. The information given here provides data to evaluate average applications for PH-3 Hydraulic Cylinders, and will assist you in proper cylinder selection.

Mounting Classes

Standard mountings for series PH-3 power cylinders fall into two basic classes and three groups. The two classes can be summarized as follows:

- Class 1 – Straight Line Force Transfer (Groups 1 and 3).
- Class 2 – Pivot Force Transfer (Group 2). Pivot mountings permit a cylinder to change its alignment in one plane.

Because a cylinder's mounting directly affects the maximum pressure at which the cylinder can be used, the chart below should be helpful in the selection of the proper mounting combination for your application. Stroke length, piston rod connection to load, extra piston rod length over standard, etc., should be considered for thrust loads. Alloy steel mounting bolts are recommended for all mounting styles, and thrust keys are recommended for Group 3.

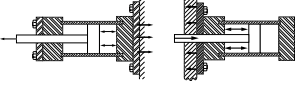
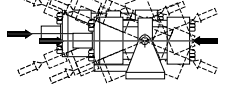
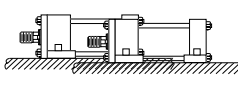
Heavy-Duty Service	Class 1 — Group 1	Class 2 — Group 2	Class 1— Group 3
	<p>FIXED MOUNTS which absorb force on cylinder centerline.</p> 	<p>PIVOT MOUNTS which absorb force on cylinder centerline.</p> 	<p>FIXED MOUNTS which do not absorb force on centerline.</p> 
For Thrust Loads	Mtg. Styles ME6, MF6	Mtg. Styles MT4, MT1, MT2, MP1	Mtg. Style MS2
For Tension Loads	Mtg. Styles ME5, MF5	Mtg. Styles MP1, MT4, MT1, MT2	Mtg. Style MS2

Rod End Data

Rod end dimension symbols as shown comply with the National Fluid Power Association dimensional code. The following chart indicates the symbols used in this catalog.

Description	Symbol
Thread diameter and pitch	KK
Length of thread	A
Length of Rod Extension from face of head to end of retracted rod	LAF (Male Thread) WF (Female Thread)

Two rod ends for PH-3 cylinders are offered as shown on the dimension pages of this catalog. They are styles 2 and 3 and are optional without price penalty. If a rod end style is not specified, a style 2 (N.F.P.A. Style SM) will be supplied.

International Rod End Threads

Piston rod threads to meet international requirements are available at extra cost. PH-3 cylinders can be supplied with British standard fine (W) or metric (M). To order, specify in model number. For dimensions, consult factory.

Special Rod Ends

If a rod end configuration other than the standard styles 2 and 3 is required, such special rod ends can be provided. The designation "Style 0" is assigned to such specials and is incorporated in the cylinder model number. To order, specify "Style 0" and give desired dimensions for KK, A, or LAF, or WF if female end. If otherwise special, send a dimensioned sketch.

Rod End Boots

Are available on request: Consult factory for details.

Special Assemblies From Standard Parts

Each dimensioned drawing in this catalog has position numbers shown on the end view to identify the four sides of the cylinder. These aid in communications and simplify the writing of specifications that cover changes in port positions, etc. Following are several suggested special assemblies that can be made up from standard parts.

- a) By calling out the position numbers for the desired locations for head and cap ports, some mounting styles can be assembled with ports located at 90° or 180° from standard. In such special assemblies, the cushion needle and check valves are also repositioned since their relation with the port position does not change.
- b) Standard mountings in different combinations can be specified on either the head or cap end. Consult the factory for details.

Single-Acting Cylinders

Maximum Pressure Rating

Bore	Rod Dia.	4:1 Design Factor (Tensile)	Heavy-Duty Service
Inches	Inches	P.S.I.	P.S.I.
10	4 1/2	2720	3000
12	5 1/2	2580	3000
14	7	2320	3000
16			
18	Consult Factory		
20			

Double-acting PH-3 cylinders are supplied as standard. They can also be used as single-acting cylinders where fluid force is applied to only one side of the piston, with the load or other external forces acting to "return" the piston after pressure is exhausted.

PH-3 Series cylinders are recommended for pressures to 3000 p.s.i. for heavy-duty service with hydraulic oil. The 4:1 design factor ratings shown are based on tensile strength of material and are for code 1 rod dia. only. Design factors at other pressures can be calculated from this rating. In addition, mounting styles, stroke, etc., should be considered because of the limiting effect they may have on these ratings.



PH-3 Large Bore – Ports

Standard Ports PH-3 Series cylinders can be furnished with either N.P.T.F. (specify PF or PK type) or S.A.E. Flange Ports (specify PH or PJ type). The largest size port is provided that can be accommodated by the head and cap in any given bore size. If specified on your order, extra ports can be provided on the sides of heads or caps that are not occupied by mountings or cushion valves.

Port Locations Standard port location is position 1, as shown in Section B, PH-3 Series Large Bore Cylinders. Cushion adjustment needle and check valve are at position 3 on all mounting styles except MS2 where they will be located at position 2.

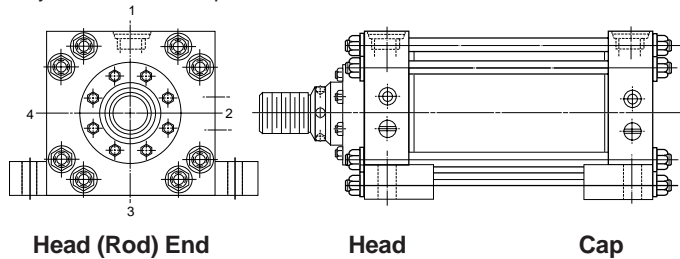

Mounting Style	Port Position Available	
	Head End	Cap End
MX0, MX1, MX2, MX3, ME5, MF5, ME6, MF6, MT4	1, 2, 3 or 4	1, 2, 3 or 4
MP1, MT2	1, 2, 3 or 4	1 or 3
MT1	1 or 3	1, 2, 3 or 4
MS2	1	1

Heads or caps which do not incorporate mounting can be rotated and assembled at no extra charge with ports 90° or 180° from standard position. To order other than standard port location, specify by position number shown in table above. In such assemblies, the cushion adjustment needle and check valve rotate accordingly, since their relationship with port position does not change.

International Ports Other port configurations to meet international requirements are available at extra cost. PH-3 cylinders can be supplied with British parallel ports (BSP) or British standard port taper (BSPT) or metric (G). To order, specify in model number. For dimension, consult factory.

Air Bleeds

In most hydraulic circuits, cylinders are considered self-bleeding when cycled the full stroke. If air bleeds are required, a 1/8" NPTF port boss can be supplied at each end of the cylinder body. To order, specify Bleed port, and indicate position desired.

Water Service Modifications

Standard When requested, Schrader can supply PH-3 cylinders with standard modifications that make the cylinders more nearly suitable for use with water as the fluid medium. The modifications include chrome-plated cylinder bore; a cadmium-plated, non-wearing internal surface; fluorocarbon piston rod seal and chrome-plated, stainless steel piston rod. On orders for water-service cylinders, be sure to specify the maximum operating pressure or the load and speed conditions. (These factors must be taken into account because of the lower tensile strength of stainless steels available for use in piston rods.)

Warranty – Schrader will warrant PH-3 Series cylinders modified for water service to be free of defects in materials or workmanship. However, Schrader cannot accept responsibility for premature failure of cylinder function, where failure is caused by corrosion, electrolysis or mineral deposits within the cylinder.

Fire-Resistant Fluids

See pages 54 and 55 for further data and information.

Stop Tubing

Long stroke cylinders, fixed or pivot mounted, tend to jackknife or buckle on push load applications, resulting in high bearing loading at the rod gland or piston. Use of a stop tube to lengthen the distance between the gland and piston when cylinder rod is fully extended is recommended to reduce these bearing loads. The drawing below shows stop tube construction for PH-3 cylinders. Refer to page 90 to determine stop tube length. To order, specify net stroke and length of stop tube.

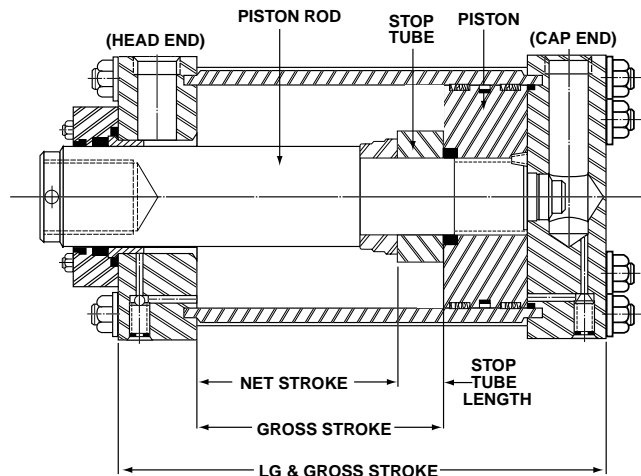

Stroke Data

PH-3 cylinders are available in any practical stroke length. The following information should prove helpful to you in selecting the proper stroke for your cylinder application.

Stroke Tolerances Stroke length tolerances are required due to buildup of tolerances of piston, head, cap and cylinder body. Standard production stroke tolerances run +1/32" to -1/16".

For closer tolerances on stroke length, it is necessary to specify the required tolerance plus the operating pressure and temperature at which the cylinder will operate. Stroke tolerances smaller than .015" are not generally practical due to elasticity of cylinders

Long Strokes When considering the use of long stroke cylinders, it is necessary that the rod diameter be of such dimension so as to provide the necessary column strength. For tension (pull) loads, a correct rod size is easily selected by specifying standard cylinders with standard rod diameters, and using them at rated or lower pressures.

For compression (push) loads, the column strength must be carefully considered. This involves the stroke length, the length of the piston rod extension, the support received from the rod end connection and gland and piston bearings, the style of mounting and the mounting attitude. It is also necessary to consider the bearing loads on pistons and glands, and to keep bearing pressures within proper limits by increasing the bearing length and the distance between piston and gland bearings. This is economically accomplished by various means. Commonly, separation of the bearings is effected with a stop tube on the piston rod much like a large diameter cushion sleeve. Other designs are provided according to the application requirements. The Stroke Chart printed on page 86 of this catalog will guide you where requirements call for unusually long strokes.

When specifying cylinders with long stroke and stop tube, be sure to call out the net stroke and the length of the stop tube. Machine design can be continued without delay by laying in a cylinder equivalent in length to the NET STROKE PLUS STOP TUBE LENGTH, which is referred to as GROSS STROKE.



Cylinder Accessories

Schrader Bellows offers a complete range of cylinder accessories to assure you of greatest versatility in present or future cylinder applications.

Rod End Accessories

Accessories offered for the rod end of the cylinder include Rod Clevis, Eye Bracket, and Pivot Pin. For dimensions and ordering details consult factory.

PH-3 Large Bore

Theoretical Push and Pull Forces for Hydraulic Cylinders — Push Force and Displacement

Cylinder Bore Size (Inches)	Piston Area (Sq. In.)	Cylinder Push Stroke Force in Pounds at Various Pressures							Displacement Per Inch of Stroke (Gallons)
		100	250	500	1000	1500	2000	3000	
10	78.54	7854	19635	39270	78540	117810	157080	235620	.3400
12	113.10	11310	28275	56550	113100	169650	226200	339300	.4896
14	153.94	15394	38485	76970	153940	230910	307880	461820	.6664
16	201.06	20106	50265	100530	201060	301590	402120	603180	.8704
18	254.47	25447	63620	127230	254470	381700	508940	763410	1.1016
20	314.16	31416	78540	157080	314160	471240	628320	942480	1.3600

Deductions for Pull Force and Displacement

Piston Rod Diameter (Inches)	Piston Rod Area (Sq. In.)	Piston Diameter Force in Pounds at Various Pressures							Displacement Per Inch of Stroke (Gallons)
		To determine Cylinder Pull Force or Displacement, deduct the following Force or Displacement corresponding to Rod Size, from selected Push Stroke Force or Displacement corresponding to Bore Size in table above.							
		100	250	500	1000	1500	2000	3000	
4 1/2	15.90	1590	3976	7950	15900	23860	31810	47700	.0688
5	19.63	1963	4908	9815	19630	29445	39260	58890	.0850
5 1/2	23.76	2376	5940	11880	23760	35640	47520	71280	.1028
7	38.48	3848	9620	19240	38480	57730	76970	115440	.1666
8	50.26	5026	12570	25130	50270	75400	100530	150780	.2176
9	63.62	6362	15900	31810	63620	95430	127230	190860	.2754
10	78.54	7854	19635	39270	78540	117810	157080	235620	.3400

Cylinder Weights, In Lbs., for PH-3 Series High Pressure Large Bore Hydraulic Cylinders

Bore Size	Rod Dia. (In.)	Rod Code	Single Rod Cylinders				Double Rod Cylinders		
			Basic Wt. Zero Stroke				Add Per In. of Stroke	Basic Weight Zero Stroke Add to All Mtg. Styles	Add Per In. of Stroke
			MT1, MT2	MT4, ME5, ME6	MF5, MF6	MP1, MS2, MS3			
10"	4 1/2	1	562	646	684	607	15	43	20
	5	3	574	656	695	619	16	50	21
	5 1/2	4	583	667	705	628	17	64	24
	7	2	620	704	742	665	21	101	32
12"	5 1/2	1	924	1057	1136	1000	22	64	29
	7	3	961	1094	1173	1036	26	101	37
	8	2	1022	1155	1234	1097	29	162	43
14"	7	1	1335	1520	1582	1485	28	101	39
	8	3	1396	1581	1643	1546	31	162	45
	10	2	1496	1681	1743	1646	39	262	61
16"	CONSULT FACTORY								
18"									
20"									

The weights shown at left are for standard PH-3 Series hydraulic cylinders equipped with various diameter piston rods. To determine the net weights of a cylinder, first select the proper basic weight for zero stroke, then calculate the weight of the cylinder stroke and add the result to the basic weight.

Extra weight for longer than standard rod extensions can be calculated from table below.

Rod Diameter	Weight Per Inch
4 1/2	4.50
5	5.56
5 1/2	6.72
7	10.89
8	14.22
10	22.23

Flow Velocity and Pressure Drop Data for Hydraulic Systems

The chart below may be used to calculate pressure loss in connecting lines at various flow velocities. The data is useful when determining hydraulic cylinder size and port size for applications where cylinder force and speed requirements are known.



S = Standard (Schedule 40) Pipe
H = Extra Strong (Schedule 80) Pipe
EH = Double Extra Strong Pipe

Tabulations based on a hydraulic oil having a viscosity of 155 SSU at 100°F — specific gravity of .87.

To determine tubing or hose losses, use I.D. closest to tubing or hose I.D.

Pressure drop does not vary with operating pressure. Avoid high pressure losses in low pressure systems. Use largest pipe size practical. Avoid flow velocities greater than 15 Ft./Sec. to reduce hydraulic line shock.

Clean Steel Pipe					Pressure Loss (Pounds Per Square Inch Per Foot Length) in Pipes at Average Flow Velocity (Feet per Second)										
Nominal Size	O.D.	I.D.	Wall Thickness	I.D. Area	5 (fps)		7 (fps)		10 (fps)		15 (fps)		20 (fps)		
					Loss	Gal. Min.	Loss	Gal. Min.	Loss	Gal. Min.	Loss	Gal. Min.	Loss	Gal. Min.	
Inches	Inches	Inches	Inch	Sq. In.											
1	S	1.315	1.049	0.133	0.863	0.10	13.45	0.13	18.85	0.34	26.90	0.57	40.35	1.42	53.80
	H		0.957	0.179	0.719	0.11	11.21	0.15	15.70	0.24	22.42	0.62	33.63	1.23	44.84
	EH		0.599	0.358	0.282	0.26	4.39	0.37	6.16	0.53	8.78	0.67	13.17	2.25	17.56
1 1/4	S	1.660	1.380	0.140	1.496	0.05	23.35	0.08	31.68	0.25	46.70	0.39	70.05	0.78	93.40
	H		1.278	0.191	1.280	0.07	19.95	0.09	28.06	0.26	39.90	0.44	58.85	0.85	79.80
	EH		0.896	0.382	0.630	0.13	9.83	0.16	13.75	0.24	19.66	0.71	29.49	1.35	39.32
1 1/2	S	1.900	1.610	0.145	2.036	0.04	31.75	0.11	44.49	0.19	63.50	0.33	95.25	0.64	127.00
	H		1.500	0.200	1.767	0.04	27.55	0.08	38.62	0.21	55.10	0.36	82.65	0.71	110.20
	EH		1.100	0.400	0.950	0.09	14.81	0.09	20.75	0.32	29.62	0.51	44.43	1.05	59.24
2	S	2.375	2.067	0.154	3.355	0.04	52.30	0.08	73.45	0.14	104.60	0.24	159.20	0.48	209.20
	H		1.939	0.218	2.953	0.03	46.00	0.09	64.60	0.15	92.00	0.26	138.00	0.52	184.00
	EH		1.503	0.436	1.773	0.04	27.65	0.12	38.78	0.21	55.30	0.36	82.95	0.72	110.60
2 1/2	S	2.875	2.469	0.203	4.788	0.03	74.75	0.07	104.80	0.11	149.50	0.20	224.25	0.37	299.00
	H		2.323	0.276	4.238	0.04	66.11	0.07	92.60	0.12	132.22	0.21	198.33	0.39	164.44
	EH		1.771	0.552	2.464	0.03	38.45	0.10	53.40	0.17	76.90	0.30	115.35	0.59	153.80

Clean Steel Pipe					Pressure Loss (Pounds Per Square Inch Per Foot Length) in Pipes at Average Flow Velocity (Feet per Second)				Equivalent Straight Pipe Length (Feet) for Circuit Components*						
Nominal Size	O.D.	I.D.	Wall Thickness	I.D. Area	25 (fps)		30 (fps)		Tee			Elbow			
					Loss	Gal. Min.	Loss	Gal. Min.				Std.	Sq.	45°	
Inches	Inches	Inches	Inch	Sq. In.											
1	S	1.315	1.049	0.133	0.863	1.64	67.25	2.24	80.70	5.7	1.7	5.7	2.6	5.7	1.2
	H		0.957	0.179	0.719	1.84	56.05	2.93	67.26	5.2	1.6	5.2	2.5	5.2	1.1
	EH		0.599	0.358	0.282	3.29	21.95	3.30	26.34	3.0	1.0	3.0	1.5	3.0	.75
1 1/4	S	1.660	1.380	0.140	1.496	1.18	116.75	1.47	140.10	7.5	2.4	7.5	3.7	7.5	1.6
	H		1.278	0.191	1.280	1.27	99.75	1.80	119.70	7.0	2.1	7.0	3.5	7.0	1.5
	EH		0.896	0.382	0.630	2.01	49.15	2.76	58.98	4.9	1.5	4.9	2.3	4.9	1.05
1 1/2	S	1.900	1.610	0.145	2.036	0.96	158.75	1.26	190.50	9.0	2.8	9.0	4.3	9.0	2.0
	H		1.500	0.200	1.767	1.06	137.75	1.36	145.30	8.2	2.6	8.2	4.0	8.2	1.8
	EH		1.100	0.400	0.950	1.51	74.05	2.14	88.86	6.5	2.0	6.5	3.0	6.5	1.4
2	S	2.375	2.067	0.154	3.355	0.69	261.50	0.85	313.80	11.0	3.5	11.0	5.5	11.0	2.5
	H		1.939	0.218	2.953	0.73	230.00	0.98	276.00	10.8	3.4	10.8	5.0	10.8	2.4
	EH		1.503	0.436	1.773	1.34	138.25	1.36	165.90	8.2	2.6	8.2	4.0	8.2	1.8
2 1/2	S	2.875	2.469	0.203	4.788	0.53	373.75	0.72	448.50	14.0	4.2	14.0	6.5	14.0	3.0
	H		2.323	0.276	4.238	0.57	330.55	0.87	396.66	13.0	4.0	13.0	6.1	13.0	2.9
	EH		1.771	0.552	2.464	0.79	192.25	1.15	230.70	10.3	3.1	10.3	4.8	10.3	2.2

*Consult valve manufacturer for pressure drops in a particular type of valve and port-to-port flow pattern.

Mounting Styles

General guidance for the selection of ISO mounting styles can be found in the SHM content of Section B. The notes which follow provide information for use in specific applications and should be read in conjunction with that information.

Trunnions

Trunnions require lubricated pillow blocks with minimum bearing clearances. Blocks should be aligned and mounted to eliminate bending moments on the trunnion pins. Self-aligning mounts must not be used to support the trunnions as bending forces can develop.

Intermediate trunnions may be positioned at any point on the cylinder body. This position, dimension XI, should be specified at the time of order. Trunnion position is not field adjustable.

Flange Mountings

Front flange-mounted (style JJ) cylinders incorporate a pilot diameter for accurate alignment on the mounting surface – see rod end dimensions for SHM cylinders. The gland retainer is integral with the head on 25, 32 and 40mm bore cylinders, while on 50mm bores and above, the circular retainer is bolted to the head.

Foot Mountings and Thrust Keys

The bending moment which results from the application of force by a foot mounted cylinder must be resisted by secure mounting and effective guidance of the load. A thrust key modification is recommended to provide positive cylinder location.

Thrust key mountings eliminate the need for fitted bolts or external keys on Style C side mounted cylinders. The gland retainer plate of 25mm & 32mm bore cylinders is extended below the nominal mounting surface to fit into a keyway milled into the mounting surface of the machine member. To order a key retainer plate in 25mm & 32mm bores, specify P in the Mounting Modification field of the model code.

Bore Ø	Rod Ø	Nominal		FA -0.075	GD	PA -0.2
		F1 Standard	F2 w/Gland Drain			
25	All	10	10 ¹	8	–	5
32	14	10	10 ¹	8	–	5
	22	10	16	8	6	5

¹ Gland drain is in the head. See page 123 for additional details about gland drain ports.

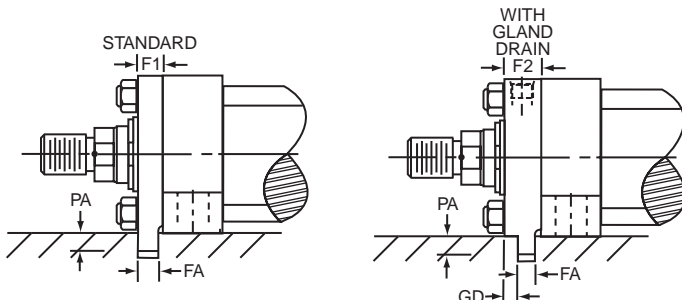

Profile of thrust key extension (with gland drain in retainer) for bore and rod combination 32mm x 22mm.

Integral Key – 25mm & 32mm Bores

All dimensions are in millimeters unless otherwise stated.

Extended Tie Rods

Cylinders may be ordered with extended tie rods in addition to another mounting style. The extended tie rods may then be used for mounting other systems or machine components.

Pivot Mountings

Pivot pins are supplied with style BB cap fixed clevis mounted cylinders. Pivot pins are not supplied with the cap fixed eye mounting, style B, or the cap with spherical bearing, style SB, where pin length will be determined by the customer's equipment.

Spherical Bearings

The service life of a spherical bearing is influenced by such factors as bearing pressure, load direction, sliding velocity and frequency of lubrication. When considering severe or unusual working conditions, please consult the factory.

Cylinders 40mm to 200mm bore utilize a keyway milled into the Style C head on the mounting lug side. A key (supplied) fits into the cylinder keyway and a corresponding keyway in the mounting surface of the machine member. To order the milled keyway and key in 40mm to 200mm bores, specify K in the Mounting Modification field of the model code.

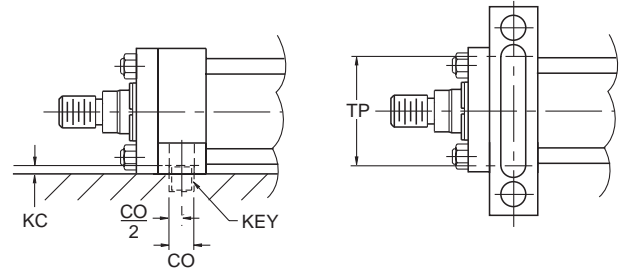

Milled Keyway – 40mm to 200mm Bore

Bore Ø	CO N9	KC +0.5	TP ² min
40	12	4	55
50	12	4.5	70
63	16	4.5	80
80	16	5	105
100	16	6	120
125	20	6	155
160	32	8	190
200	40	8	220

² Suggested Key Length

Key				
Bore Ø	Width	Height	Length	Part No.
40	12	8	55	0941540040
50	12	8	70	0941540050
63	16	10	80	0941540063
80	16	10	105	0941540080
100	16	10	120	0941540100
125	20	12	155	0941540125
160	32 ³	18	190	0941540160
200	40	22	220	0941540200

³ Not to ISO6020/2.



Mounting Information

Mounting Bolts and Nuts

Parker recommends that mounting bolts with a minimum strength of ISO 898/1 grade 10.9 should be used for fixing cylinders to the machine or base. This recommendation is of particular importance where bolts are placed in tension or subjected to shear forces. Mounting bolts, with lubricated threads, should be torque loaded to their manufacturer's recommended figures. Tie rod mounting nuts should be to a minimum strength of ISO 898/2 grade 10, torque loaded to the figures shown.

Bore Ø	Tie Rod Torque Nm
25	4.5-5.0
32	7.6-9.0
40	19.0-20.5
50	68-71
63	68-71
80	160-165
100	160-165
125	450-455
160	815-830
200	1140-1155

Intermediate or Additional Mountings

Long cylinders with fixed mountings such as extended tie rods may require additional support to counter sagging or the effects of vibration. This may be provided mid-way along the cylinder body in the form of an intermediate mounting or, with end-mounted cylinders, as an additional mounting supporting the free end of the cylinder. Please contact the factory for further information. The maximum unsupported stroke lengths which Parker recommends for each bore size are shown in the table below.

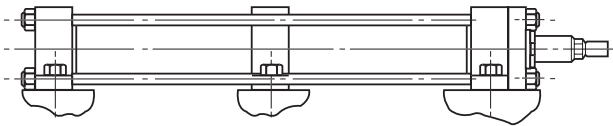

Intermediate Foot Mounting

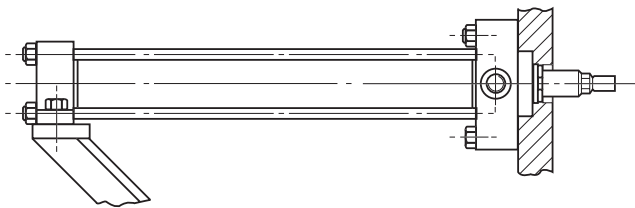

End Support Mounting

Maximum Stroke Lengths of Unsupported Cylinders (in mm)

Bore Ø	Intermediate Mounting	End Support Mounting
25, 32, 40	1500	1000
50, 63, 80	2000	1500
100, 125	3000	2000
160, 200	3500	2500

All dimensions are in millimeters unless otherwise stated.

Metric Hydraulic Cylinders SHM Series

Tie Rod Supports

To increase the resistance to buckling of long stroke cylinders, tie rod supports may be fitted. These move the tie rods radially outwards and allow longer than normal strokes to be used without the need for an additional mounting.

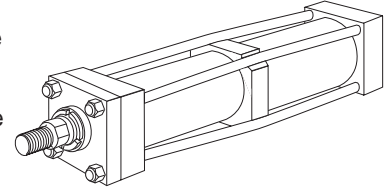

Bore Ø	Stroke (meters)												No. of Supports Required
	0.9	1.2	1.5	1.8	2.1	2.4	2.7	3.0	3.3	3.6	3.9	4.2	
25	1	1	2	Consult Factory									
32	-	1	1	2	Consult Factory								
40	-	-	1	1	1	2	2	Consult Factory					
50	-	-	-	1	1	1	2	2	2	2	3		
63	-	-	-	-	-	1	1	1	1	2	2		
80	-	-	-	-	-	-	-	1	1	1	1		
100	-	-	-	-	-	-	-	-	-	1	1	1	

Stroke Tolerances

Stroke length tolerances are required due to the build-up of tolerances of piston, head, cap and cylinder body. Standard production stroke tolerances are 0 to +2mm on all bore sizes and stroke lengths. For closer tolerances, please specify the required tolerance plus the operating temperature and pressure. Stroke tolerances of less than 0.4mm are generally impracticable due to the elasticity of cylinders. In these cases, the use of a stroke adjuster should be considered. Tolerances of stroke dependent dimensions for each mounting style are shown in the table below.

Stroke Dependent Tolerances

Mounting Style	Dimensions	Tolerance - for strokes up to 3m
All styles - port dimensions	Y	±2
	PJ	±1.25
JJ (ME5)	ZB	max
HH (ME6)	ZJ	±1
BB (MP1) B(MP3)	XC	±1.25
SB (MP5)	XO	±1.25
C (MS2)	XS	±2
	ZB	max
	SS	±1.25
D (MT1)	XG	±2
	ZB	max
DB (MT2)	XJ	±1.25
	ZB	max
DD (MT4)	XV	±2
	ZB	max
TD (MX1) TC (MX2) TB (MX3)	BB	+3 0
TB (MX3)		max
TD (MX1) TB (MX3)		WH
TD (MX1) TC (MX2) TB (MX3)	ZJ	±1

Calculation of Cylinder Diameter

General Formula

The cylinder output forces are derived from the formula:

$$F = \frac{P \times A}{10000}$$

Where F = Force in kN.

P = Pressure at the cylinder in bar.

A = Effective area of cylinder piston in square mm.

Prior to selecting the cylinder bore size, properly size the piston rod for tension (pull) or compression (push) loading (see the Piston Rod Selection Chart).

If the piston rod is in compression, use the 'Push Force' table below, as follows:

1. Identify the operating pressure closest to that required.
2. In the same column, identify the force required to move the load (always rounding up).
3. In the same row, look along to the cylinder bore required.

If the cylinder envelope dimensions are too large for the application, increase the operating pressure, if possible, and repeat the exercise.

If the piston rod is in tension, use the 'Deduction for Pull Force' table. The procedure is the same but, due to the reduced area caused by the piston rod, the force available on the 'pull' stroke will be smaller. To determine the pull force:

1. Follow the procedure for 'push' applications as described above.
2. Using the 'pull' table, identify the force indicated according to the rod and pressure selected.
3. Deduct this from the original 'push' force. The resultant is the net force available to move the load.

If this force is not large enough, repeat the process and increase the system operating pressure or cylinder diameter if possible. For assistance, contact your local authorized Schrader Bellows distributor.

Push Force

Bore Ø mm	Bore Area sq. mm	Cylinder Push Force in kN						
		10 bar	40 bar	63 bar	100 bar	125 bar	160 bar	210 bar
25	491	0.5	2.0	3.1	4.9	6.1	7.9	10.3
32	804	0.8	3.2	5.1	8.0	10.1	12.9	16.9
40	1257	1.3	5.0	7.9	12.6	15.7	20.1	26.4
50	1964	2.0	7.9	12.4	19.6	24.6	31.4	41.2
63	3118	3.1	12.5	19.6	31.2	39.0	49.9	65.5
80	5027	5.0	20.1	31.7	50.3	62.8	80.4	105.6
100	7855	7.9	31.4	49.5	78.6	98.2	125.7	165.0
125	12272	12.3	49.1	77.3	122.7	153.4	196.4	257.7
160	20106	20.1	80.4	126.7	201.1	251.3	321.7	422.2
200	31416	31.4	125.7	197.9	314.2	392.7	502.7	659.7

Deduction for Pull Force

Piston Rod Ø mm	Piston Rod Area sq. mm	Reduction in Force in kN						
		10 bar	40 bar	63 bar	100 bar	125 bar	160 bar	210 bar
12	113	0.1	0.5	0.7	1.1	1.4	1.8	2.4
14	154	0.2	0.6	1.0	1.5	1.9	2.5	3.2
18	255	0.3	1.0	1.6	2.6	3.2	4.1	5.4
22	380	0.4	1.5	2.4	3.8	4.8	6.1	8.0
28	616	0.6	2.5	3.9	6.2	7.7	9.9	12.9
36	1018	1.0	4.1	6.4	10.2	12.7	16.3	21.4
45	1591	1.6	6.4	10.0	15.9	19.9	25.5	33.4
56	2463	2.5	9.9	15.6	24.6	30.8	39.4	51.7
70	3849	3.8	15.4	24.2	38.5	48.1	61.6	80.8
90	6363	6.4	25.5	40.1	63.6	79.6	101.8	133.6
110	9505	9.5	38.0	59.9	95.1	118.8	152.1	199.6
140	15396	15.4	61.6	97.0	154.0	192.5	246.3	323.3



Piston Rod Size Selection

To select a piston rod for thrust (push) applications, follow these steps:

1. Determine the type of cylinder mounting style and rod end connection to be used. Consult the Stroke Factor table and determine which factor corresponds to the application.
2. Using the appropriate stroke factor, determine the 'basic length' from the equation:

$$\text{Basic Length} = \text{Net Stroke} \times \text{Stroke Factor}$$

(The graph is prepared for standard rod extensions beyond the face of the gland retainers. For rod extensions greater than standard, add the increases to the net stroke to arrive at the 'basic length'.)

3. Calculate the load imposed for the thrust application by multiplying the full bore area of the cylinder by the system pressure, or by referring to the Push and Pull Force charts.
4. Using the graph below, look along the values of 'basic length' and 'thrust' as found in 2 and 3 above, and note the point of intersection.

The correct piston rod size is read from the diagonally curved line labelled 'Rod Diameter' above the point of intersection.

Stop Tubes

The required length of stop tube, where necessary, is read from the vertical columns on the right of the graph below by following the horizontal band within which the point of intersection, determined in steps 2 and 3 opposite, lies.

Note that stop tube requirements differ for fixed and pivot mounted cylinders.

If the required length of stop tube is in the region labeled 'consult factory', please submit the following information:

1. Cylinder mounting style.
2. Rod end connection and method of guiding load.
3. Bore required, stroke, length of rod extension (dimensions WF) if greater than standard.
4. Mounting position of cylinder. (Note: if at an angle or vertical, specify the direction of the piston rod.)
5. Operating pressure of cylinder, if limited to less than the standard pressure for the cylinder selected.

When specifying a cylinder with a stop tube, state the **gross** stroke of the cylinder and the length of the stop tube. The gross stroke is equal to the net (working) stroke of the cylinder plus the stop tube length. See the example below:

Ex. 80-JJ-SHM-R-E-S-14-M1375M1100

1) Stop tube = 175

2) Net stroke = 1200

– the cylinder net stroke will be 1200mm with 175mm of stop tube.

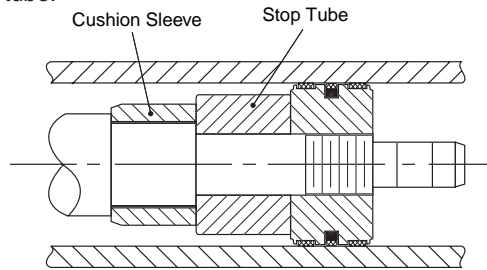

Piston Rod Selection Chart

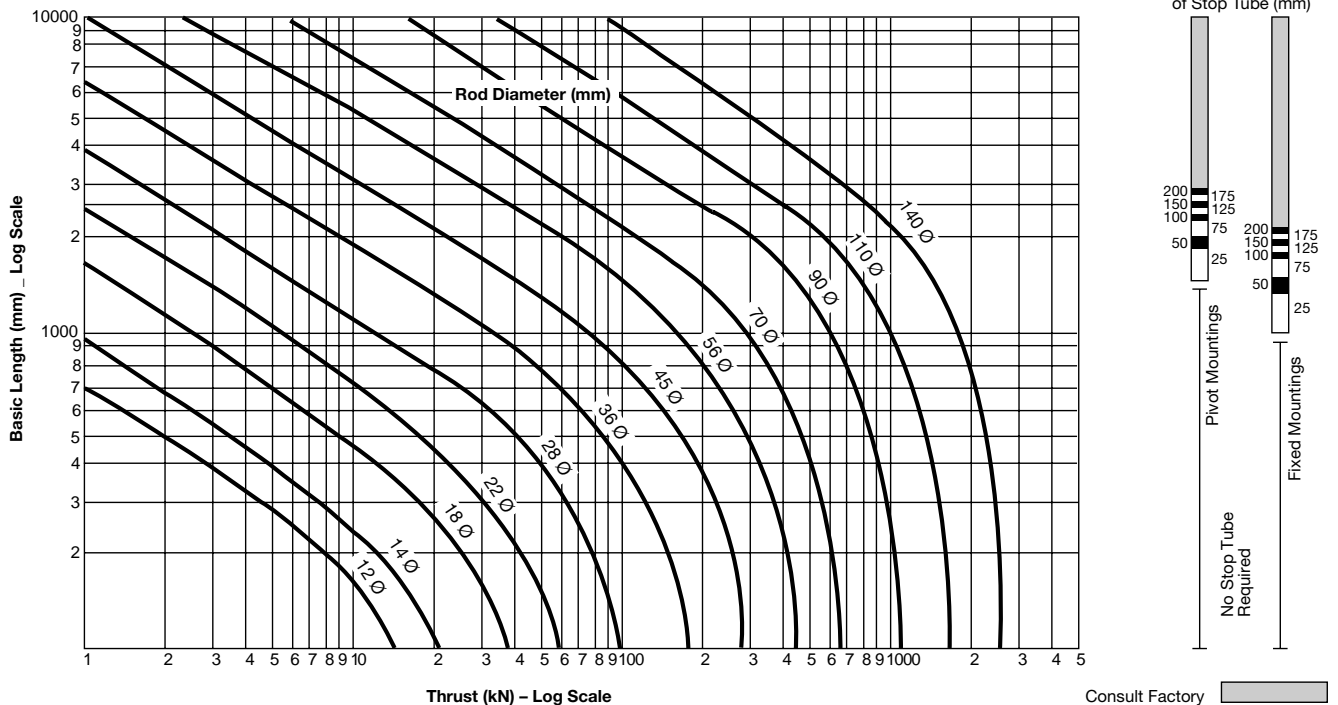

Stroke Factors

The stroke factors below are used in the calculation of cylinder 'basic length' – see Piston Rod Size Selection.

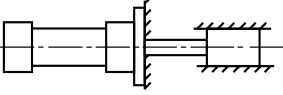
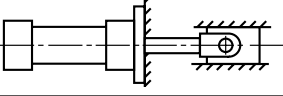
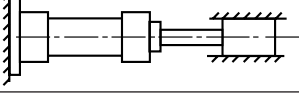
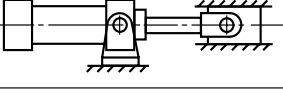
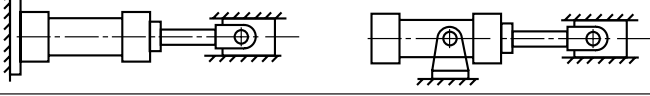
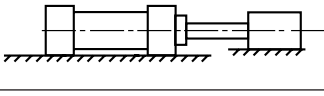
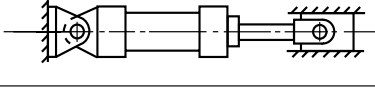
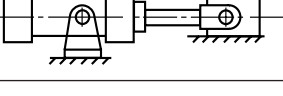
Rod End Connection	Mounting Style	Type of Mounting	Stroke Factor
Fixed and Rigidly Guided	TB, TD, C, JJ		0.5
Pivoted and Rigidly Guided	TB, TD, C, JJ		0.7
Fixed and Rigidly Guided	TC, HH		1.0
Pivoted and Rigidly Guided	D		1.0
Pivoted and Rigidly Guided	TC, HH, DD		1.5
Supported but not Rigidly Guided	TB, TD, C, JJ		2.0
Pivoted and Rigidly Guided	B, BB, DB, SB		2.0
Pivoted and Supported but not Rigidly Guided	DD		3.0

Long Stroke Cylinders

When considering the use of long stroke cylinders, the piston rod should be of sufficient diameter to provide the necessary column strength.

For tensile (pull) loads, the rod size is selected by specifying standard cylinders with standard rod diameters and using them at or below the rated pressure.

Stop tube is recommended to lengthen the distance between the gland and piston to reduce bearing loads when the cylinder is fully extended. This is especially true of horizontally mounted and long stroke cylinders. Long stroke cylinders achieve additional stability through the use of a stop tube.

C

An Introduction to Cushioning

Cushioning is recommended as a means of controlling the deceleration of masses, or for applications where piston speeds are in excess of 0.1m/s and the piston will make a full stroke. Cushioning extends cylinder life and reduces undesirable noise and hydraulic shock.

Built-in 'cushions' are optional and can be supplied at the head and cap ends of the cylinder without affecting its envelope or mounting dimensions.

Standard Cushioning

Ideal cushion performance shows an almost uniform absorption of energy along the cushioning length, as shown. Many

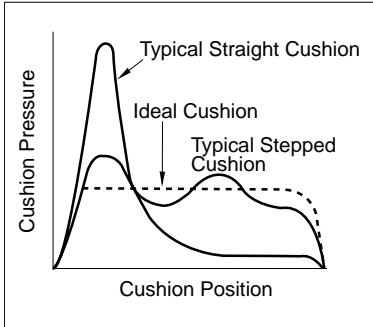

forms of cushioning exist, and each has its own specific merits and advantages. In order to cover the majority of applications, SHM cylinders are supplied with profiled cushioning as standard. Final speed may be adjusted using the cushion screws. The performance of

profiled cushioning is indicated on the diagram, and cushion performance for each of the rod sizes available is illustrated graphically in the charts on the next page.

Note: Cushion performance will be affected by the use of water or high water based fluids. Please consult the factory for details.

Cushion Length

Where specified, SHM cylinders incorporate the longest cushion sleeve and spear that can be accommodated within the standard envelope without reducing the rod bearing and piston bearing lengths. See table of cushion lengths on the following pages. Cushions are adjustable via recessed needle valves.

Cushion Calculations

The charts on the next page show the energy absorption capacity for each bore/rod combination at the head (annulus) and the cap (full bore) ends of the cylinder. The charts are valid for piston velocities in the range 0.1 to 0.3m/s. For velocities between 0.3 and 0.5m/s, the energy values derived from the charts should be reduced by 25%. For velocities of less than 0.1m/s where large masses are involved, and for velocities of greater than 0.5m/s, a special cushion profile may be required. Please consult the factory for details.

The cushion capacity of the head end is less than that of the cap, and reduces to zero at high drive pressures due to the pressure intensification effect across the piston.

The energy absorption capacity of the cushion decreases with drive pressure.

Formula

Cushioning calculations are based on the formula $E = \frac{1}{2}mv^2$ for horizontal applications. For inclined or vertically downward or upward applications, this is modified to:

$$E = \frac{1}{2}mv^2 + mgl \times 10^{-3} \times \sin(a)$$

(for inclined or vertically downward direction of mass)

$$E = \frac{1}{2}mv^2 - mgl \times 10^{-3} \times \sin(a)$$

(for inclined or vertically upward direction of mass)

Where:

E = energy absorbed in Joules

g = acceleration due to gravity = 9.81m/s²

v = velocity in meters/second

l = length of cushion in millimeters

m = mass of load in kilograms (including piston, rod and rod end accessories)

a = angle to the horizontal in degrees

p = pressure in bar

Example

The following example shows how to calculate the energy developed by masses moving in a straight line. For non-linear motion, other calculations are required; please consult the factory. The example assumes that the bore and rod diameters are already appropriate for the application. The effects of friction on the cylinder and load have been ignored.

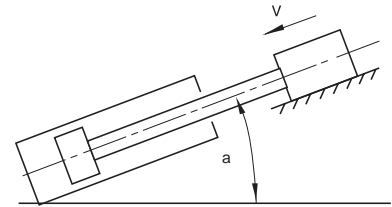

Selected bore/rod 160/70mm (No.1 rod).
Cushioning at the cap end.

- Pressure = 160 bar
- Mass = 10000kg
- Velocity = 0.4m/s
- Cushion length = 41mm
- a = 45°
- Sin (a) = 0.70

$$E = \frac{1}{2}mv^2 + mgl \times 10^{-3} \times \sin(a)$$

$$= \frac{10000 \times 0.4^2}{2} + 10000 \times 9.81 \times \frac{41}{10^3} \times 0.70$$

$$= 800 + 2815 = 3615 \text{ Joules}$$

Note that velocity is greater than 0.3m/s; therefore, a de-rating factor of 0.75 must be applied before comparison with the curves on the cushioning charts. Applying this factor to the calculated energy figure of 3615 Joules gives a corrected energy figure of:

$$\frac{3615}{0.75} = 4820 \text{ Joules}$$

Comparison with the curve shows that the standard cushion can safely decelerate this load. If the calculated energy exceeds that indicated by the curve, select a larger bore cylinder and re-calculate.

Cushion Energy Absorption Capacity Data

The cushion energy absorption capacity data shown below is based on the maximum fatigue-free pressure developed in the tube. For applications with a life cycle of less than

10⁶ cycles, greater energy absorption figures can be applied. Please consult the factory if further information is required.

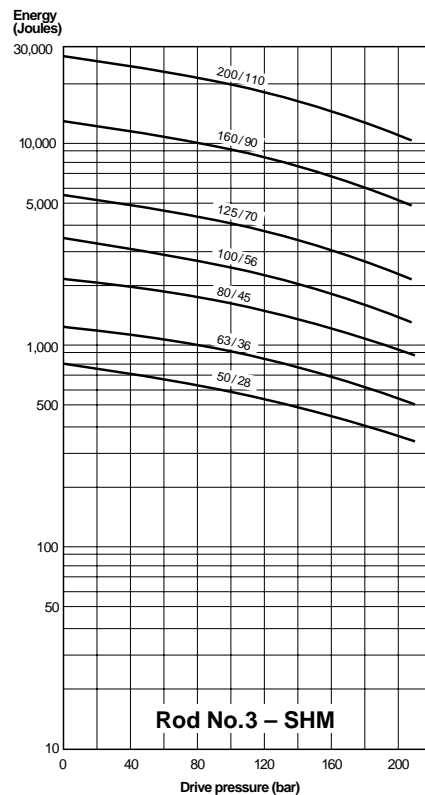
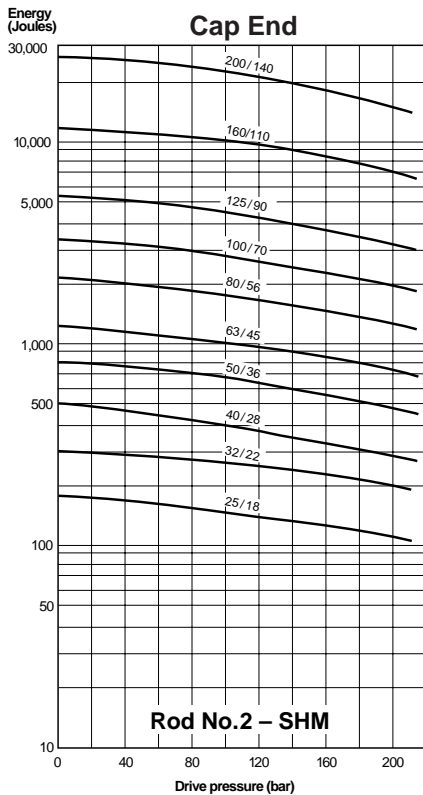
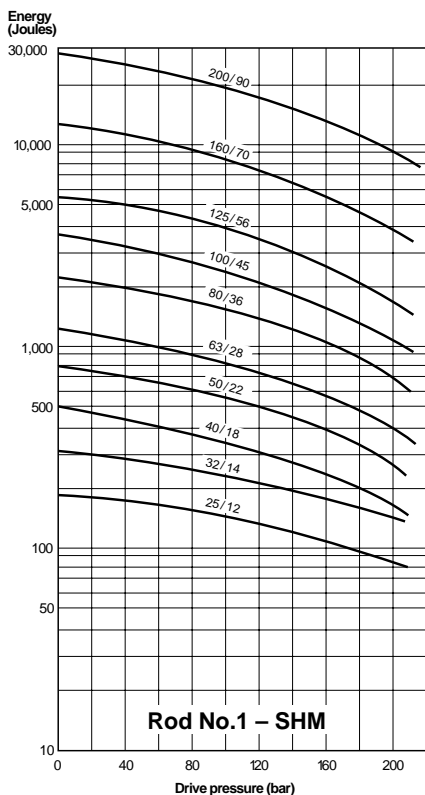
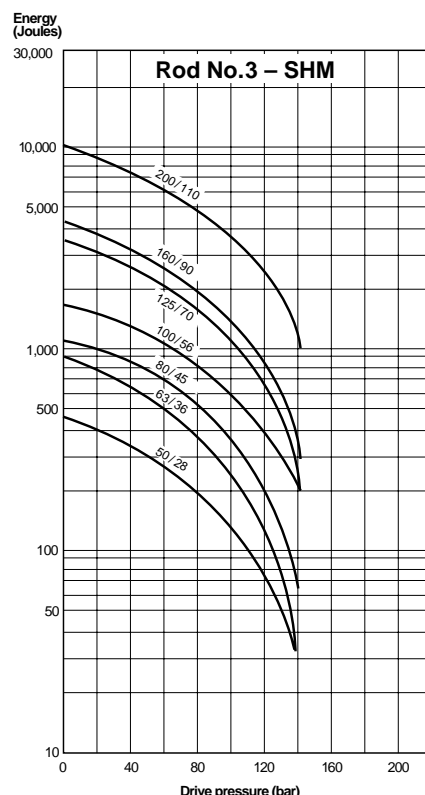
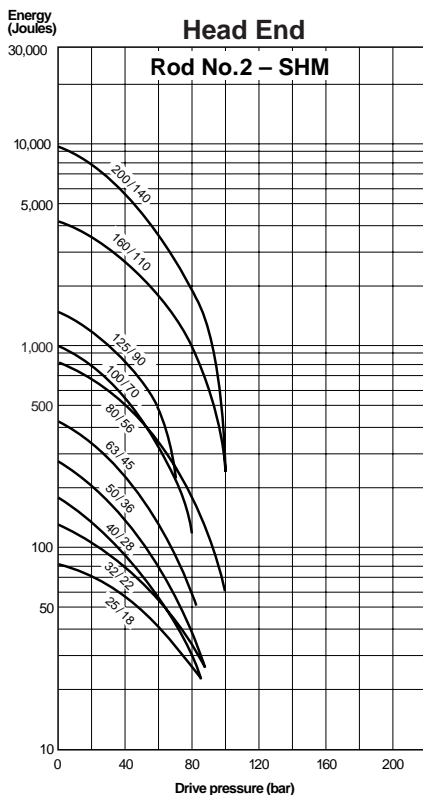
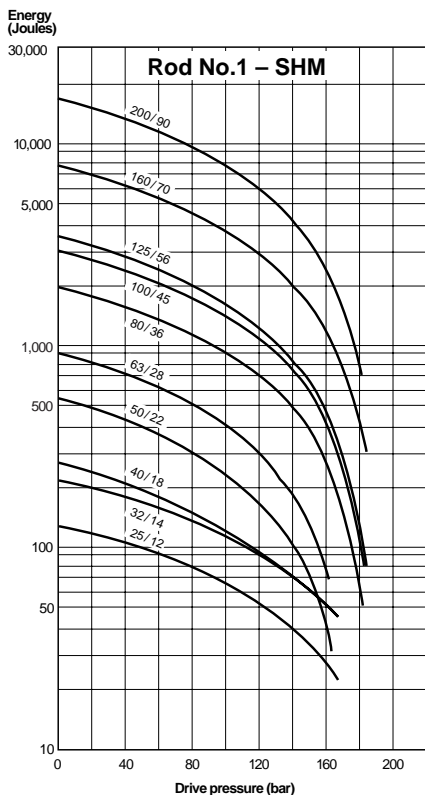

Cushion Length, Piston and Rod Mass

Bore Ø	Rod No.	Rod Ø	Cushion Length						Mass	
			Rod No. 1		Rod No. 2		Rod No. 3		Piston & Rod Zero Stroke kg	Rod Only per 10mm Stroke kg
			Head	Cap	Head	Cap	Head	Cap		
25	1	12	22	20	24	20	-	-	0.12	0.01
	2	18							0.16	0.02
32	1	14	24	20	24	20	-	-	0.23	0.01
	2	22							0.30	0.03
40	1	18	29	29	29	30	-	-	0.44	0.02
	2	28							0.60	0.05
50	1	22	29	29	29	29	29	29	0.70	0.03
	2	36							0.80	0.05
	3	28							0.95	0.08
63	1	28	29	29	29	29	29	29	1.20	0.05
	2	45							1.35	0.08
	3	36							1.60	0.12
80	1	36	35	32	27	32	35	32	2.30	0.08
	2	56							2.50	0.12
	3	45							2.90	0.19
100	1	45	35	32	26	32	29	32	4.00	0.12
	2	70							4.40	0.19
	3	56							5.10	0.30
125	1	56	28	32	27	32	27	32	7.10	0.19
	2	90							8.00	0.30
	3	70							9.40	0.50
160	1	70	34	41	34	41	34	41	13.70	0.30
	2	110							15.30	0.50
	3	90							17.20	0.75
200	1	90	46	56	49	56	50	56	27.00	0.50
	2	140							30.00	0.75
	3	110							34.00	1.23

Pressure Limitations – Introduction

The pressure limitations of a hydraulic cylinder must be reviewed when considering its application. To assist the designer in obtaining the optimum performance from a cylinder, the information which follows highlights the recommended minimum and maximum pressures according to application. If in doubt, please consult the factory.

Minimum Pressure

Due to factors such as seal friction, the minimum operating pressure for SHM cylinders is 5 bar. Below this pressure, low friction seals should be specified. If in doubt, please consult the factory.

Maximum Pressure

SHM cylinders are designed to the mounting dimensions specified in ISO 6020/2 for 160 bar cylinders but, due to the selection of materials, they can be used at higher pressures depending on the application and the choice of rod size and rod end style. As a result, the majority of these cylinders can be operated at 210 bar.

Cylinder Body (Pressure Envelope)

In many applications, the pressure developed within a cylinder may be greater than the working pressure, due to pressure intensification across the piston and cushioning. In most cases, this intensification does not affect the cylinder mountings or piston rod threads in the form of increased loading. It may, however, affect the cylinder body and induce fatigue failure or cause premature seal wear. It is important, therefore, that the pressure due to cushioning or intensification does not exceed the 340 bar fatigue limit of the cylinder body. The cushion energy absorption data on the previous page is based on this maximum induced pressure. If in doubt, please consult the factory.

All dimensions are in millimeters unless otherwise stated.

Ports

Standard Ports

SHM Series cylinders are supplied with BSP parallel threaded ports, of a size suitable for normal speed applications – see table opposite. SHM cylinders are also available with a variety of optional ports.

Oversize Ports

For higher speed applications. SHM Series cylinders are available with oversize BSP or metric ports to the sizes shown in the table opposite, or with extra ports in head or cap faces that are not used for mountings or cushion screws. On 25 mm and 32 mm bore cylinders, 20mm high port bosses are necessary to provide the full thread length at the cap end – see rod end dimensions for increased height at the head end. Note that Y and PJ dimensions may vary slightly to accommodate oversize ports – please contact the factory where these dimensions are critical.

Port Size and Piston Speed

One of the factors which influences the speed of a hydraulic cylinder is fluid flow in the connecting lines. Due to piston rod displacement, the flow at the cap end port will be greater than that at the head end, at the same piston speed. Fluid velocity in connecting lines should be limited to 5m/s to minimize fluid turbulence, pressure loss and hydraulic shock. The tables opposite are a guide for use when determining whether cylinder ports are adequate for the application. Data shown gives piston speeds for standard and oversize ports and connecting lines where the velocity of the fluid is 5m/s.

If the desired piston speed results in a fluid flow in excess of 5 m/s in connecting lines, larger lines with two ports per cap should be considered. Parker recommends that a flow rate of 12 m/s in connecting lines should not be exceeded.

Speed Limitations

Where large masses are involved, or piston speeds exceed 0.1m/s and the piston will make a full stroke, cushions are recommended – see cushion information. For cylinders with oversize ports and with a flow exceeding 8m/s into the cap end, a 'non-floating cushion' should be specified. Please consult the factory.

Ports, Air Bleeds and Cushion Adjustment Location

The table below shows standard positions for ports, and cushion adjusting screws where fitted. Air bleeds (see optional features) may be fitted in unoccupied faces of the head or cap, depending on mounting.

Bore Ø	Standard Cylinder Ports				
	Port Size BSP/G Inches	Port Size Metric ¹	Bore of Connecting Lines	Cap End Flow in l/min @ 5m/s	Piston Speed m/s
25	1/4	M14x1.5	7	11.5	0.39
32	1/4	M14x1.5	7	11.5	0.24
40	3/8	M18x1.5	10	23.5	0.31
50	1/2	M22x1.5	13	40	0.34
63	1/2	M22x1.5	13	40	0.21
80	3/4	M27x2	15	53	0.18
100	3/4	M27x2	15	53	0.11
125	1	M33x2	19	85	0.12
160	1	M33x2	19	85	0.07
200	1 1/4	M42x2	24	136	0.07

Bore Ø	Oversize Cylinder Ports (Not to DIN)				
	Port Size BSP/G Inches	Port Size Metric ¹	Bore of Connecting Lines	Cap End Flow in l/min @ 5m/s	Piston Speed m/s
25	3/8 ²	M18x1.5 ^{2,3}	10	23.5	0.80
32	3/8 ²	M18x1.5 ^{2,3}	10	23.5	0.48
40	1/2	M22x1.5 ³	13	40	0.53
50	3/4	M27x2 ³	15	53	0.45
63	3/4	M27x2 ³	15	53	0.28
80 ⁴	1	M33x2	19	85	0.28
100 ⁴	1	M33x2	19	85	0.18
125 ⁴	1 1/4	M42x2	24	136	0.18
160 ⁴	1 1/4	M42x2	24	136	0.11
200 ⁴	1 1/2	M48x2	30	212	0.11

¹Not to DIN 24 554

²20mm high port bosses fitted at cap end

³ISO 6149 ports are not available on some bore/rod combinations

⁴Consult factory – not normally available on these bore sizes

Not recommended for JJ mountings at pressures above 100 bar

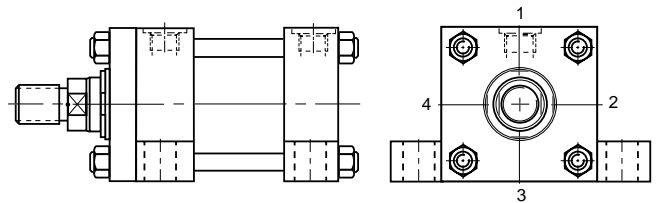

Ports at position 2 or 4 in 25mm to 100mm bore sizes of mounting style C are offset toward position 1 and are not available in the head of 25mm and 32mm bores with number 2 rods. 25mm and 32mm bore heads will not be elongated 5mm toward position 2 or 4 when a port is specified at either of those two locations (the 5mm elongation at position 1 will remain). Contact the factory for the offset dimension.

Positions of Ports and Cushion Screws in Head and Cap		Mounting Styles																																						
		TB, TC and TD				JJ				HH				C ⁵		B and BB				SB		D		DB				DD												
Head	Port	1	2	3	4	1	2	3	4	1	2	3	4	1	2	4	1	2	3	4	1	2	3	4	1	3	1	2	3	4	1	2	3	4	1	2	3	4		
	Cushion	2	3	4	1	3	3	1	1	3	4	1	2	2	4	2	2	3	4	1	2	3	4	1	3	1	3	4	1	2	3	4	1	2	3	4	1	2		
Cap	Port	1	2	3	4	1	2	3	4	1	2	3	4	1	2	4	1	2	3	4	1	2	3	4	1	2	3	4	1	3	1	3	1	2	3	4	1	2	3	4
	Cushion	2	3	4	1	3	4	1	2	3	3	1	1	2	4	2	2	3	4	1	2	3	4	1	3	4	1	2	3	1	3	4	1	2	3	4	1	2		

⁵Ports at position 2 or 4 in 25mm to 100mm bores are offset toward position 1.

All dimensions are in millimeters unless otherwise stated.



Cylinder Port Options

- Option "T" SAE Straight Thread O-Ring Port. Recommended for most hydraulic applications.
- Option "U" Conventional NPTF Ports (Dry-Seal Pipe Threads). Recommended for pneumatic applications only.
- Option "R" BSPP Port (British Parallel Thread). ISO 228 port commonly used in Europe. See Figure R-G below.
- Option "P" SAE Flange Ports Code 61 (3000 psi). Recommended for hydraulic applications requiring larger port sizes.
- Option "B" BSPT (British Tapered Thread).
- Option "M" Metric Straight Thread Port similar to Option "R" with metric thread. Popular in some European applications. See Figure R-G below.
- Option "Y" ISO-6149-1 Metric Straight Thread Port. Recommended for all hydraulic applications designed per ISO standards. See Figure Y below.

Bore	"T" SAE	"U" NPTF Pipe Thread	"R" BSPP Parallel Thread (Standard)	"P" SAE 4-Bolt Flange Nom. Size	"B" BSPT Taper Thread	"M" Metric Straight Thread	"Y" ISO-6149-1 Metric Straight Thread
25	#6	1/4	1/4	N/A	1/4	M14 x 1.5	M14 x 1.5
32	#6	1/4	1/4	N/A	1/4	M14 x 1.5	M14 x 1.5
40	#6	3/8	3/8	N/A	3/8	M18 x 1.5	M18 x 1.5
50	#10	1/2	1/2	N/A	1/2	M22 x 1.5	M22 x 1.5
63	#10	1/2	1/2	1/2	1/2	M22 x 1.5	M22 x 1.5
80	#12	3/4	3/4	3/4	3/4	M27 x 2	M27 x 2
100	#12	3/4	3/4	3/4	3/4	M27 x 2	M27 x 2
125	#16	1	1	1	1	M33 x 2	M33 x 2
160	#16	1	1	1	1	M33 x 2	M33 x 2
200	#20	1-1/4	1-1/4	1-1/4	1-1/4	M42 x 2	M42 x 2

BSPP Port for SHM Series

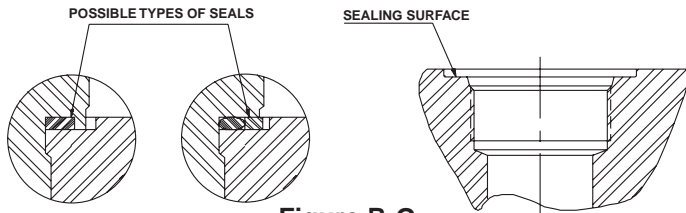

Figure R-G

ISO 6149-1 Port for SHM Series

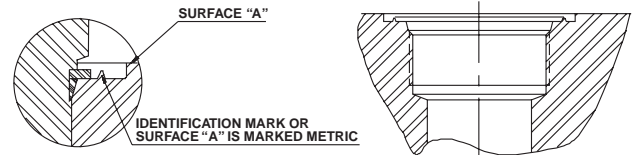

Figure Y

Weights – SHM Series Cylinders

Bore Ø	Rod Ø	Mounting Styles – Weight at Zero Stroke						Weight per 10mm Stroke kg
		TB, TC TD	C	JJ, HH	B, BB, SB	D, DB	DD	
		kg	kg	kg	kg	kg	kg	kg
25	12						1.5	0.05
	18	1.2	1.4	1.5	1.4	1.3	1.6	0.06
32	14	1.6	1.9	2.0	1.9	1.7	2.0	0.06
	22	1.7						0.08
40	18	3.7	4.0	4.7	4.2	3.9	4.6	0.09
	28	3.8	4.1	4.8	4.3	4.0	4.7	0.12
50	22	5.9	6.5	7.2	7.0	6.3	7.9	0.14
	28	6.0	6.6	7.3	7.1		8.0	0.16
	36				7.2	6.4	8.0	0.18
63	28	8.5	9.7	10.1	10.1	8.9	10.6	0.19
	36	8.6	9.8	10.2	10.2	9.0	10.7	0.22
	45	8.7	9.9	10.3	10.4	9.1	10.9	0.27
80	36	16.0	17.3	18.9	19.5	16.5	20.5	0.27
	45	16.1	17.4	19.0	19.6	16.6		0.32
	56	16.3	17.7	19.2	19.8	16.8	20.7	0.39

Bore Ø	Rod Ø	Mounting Styles – Weight at Zero Stroke						Weight per 10mm Stroke kg
		TB, TC TD	C	JJ, HH	B, BB, SB	D, DB	DD	
		kg	kg	kg	kg	kg	kg	kg
100	45	22.0	24.0	25.0	28.0	22.7	26.0	0.40
	56			26.0			27.0	0.47
	70	23.0	25.0	26.0	29.0	23.2	27.0	0.58
125	56	42.0	44.0	48.0	53.0	43.0	48.0	0.65
	70			45.0			54.0	49.0
	90	43.0	45.0	49.0	54.0	44.0	50.0	0.95
160	70	69.0	73.0	78.0	90.0	71.0	84.0	1.00
	90			78.0			91.0	72.0
	110	70.0	74.0	79.0	92.0	72.0	85.0	1.40
200	90	122.0	129.0	138.0	157.0	127.0	153.0	1.50
	110				123.0			130.0
	140	124.0	131.0	140.0	160.0	129.0	155.0	2.30

All dimensions are in millimeters unless otherwise stated.

Seals and Fluid Data

Group	Seal Materials – a combination of:	Fluid Medium to ISO 6743/4-1982	Temperature Range
1	Nitrile (NBR), PTFE, enhanced polyurethane (AU)	Mineral oil HH, HL, HLP, HLP-D, HM, HV, MIL-H-5606 oil, nitrogen	-20°C to + 80°C
5	Fluorocarbon elastomer (FPM) Fluorocarbon, PTFE	Fire resistant fluids based on phosphate esters (HFD-R) Also suitable for hydraulic oil at high temperatures/environments. Not suitable for use with Skydrol. See fluid manufacturer's recommendations.	-20°C to + 150°C

Operating Medium

Sealing materials used in the standard cylinder are suitable for use with most petroleum-based hydraulic fluids.

Special seals are available for use with water-glycol or water-in-oil emulsions, and with fluids such as fire-resistant synthetic phosphate ester and phosphate ester-based fluids.

If there is any doubt regarding seal compatibility with the operating medium, please consult the factory.

The table above is a guide to the sealing compounds and operating parameters of the materials used for standard and optional rod gland, piston and body seals

Temperature

Standard seals can be operated at temperatures between -20°C and +80°C. Where operating conditions result in temperatures which exceed these limits, special seal compounds may be required to ensure satisfactory service life – please consult the factory.

Special Seals

Group 1 seals are fitted as standard to SHM cylinders. For other duties, the optional seal group 5 is available – please see the cylinder order code for SHM (ISO) cylinders. Special seals, in addition to those shown in the table above, can also be supplied. Please insert an S (Special) in the order code and specify fluid medium when ordering.

Water Service

Special cylinders are available for use with water as the fluid medium. Modifications include a stainless steel piston rod with lipseal piston, and plating of internal surfaces. When ordering, please specify the maximum operating pressure or load/speed conditions.

Warranty

Schrader Bellows warrants cylinders modified for use with water or water base fluids to be free of defects in materials and workmanship, but cannot accept responsibility for premature failure caused by corrosion, electrolysis or mineral deposits in the cylinder.

Low Friction Seals

For applications where very low friction and an absence of stick-slip are important, the option of low friction seals is available. Please consult the factory.

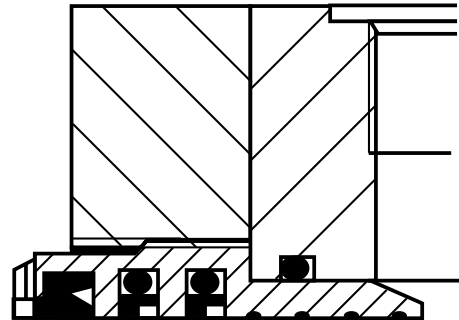

Metallic Rod Wipers

Metallic rod wipers replace the standard wiper seal, and are recommended where dust or splashing might damage the wiper seal material. Metallic rod wipers do not affect cylinder dimensions.

Proximity Sensors

EPS proximity switches can be fitted to give reliable end of stroke signals.

Position Feedback

Linear position transducers of various types are available for SHM Series cylinders. Please contact the factory for further details.

Rod End Bellows

Unprotected piston rod surfaces which are exposed to contaminants with air hardening properties can be protected by rod end bellows. Longer rod extensions are required to accommodate the collapsed length of the bellows. Please consult the factory for further information.



Gland Drains

The tendency of hydraulic fluid to adhere to the piston rod can result in an accumulation of fluid in the cavity behind the gland wiperseal under certain operating conditions. This may occur with long stroke cylinders; where there is a constant back pressure as in differential circuitry, or where the ratio of the extend speed to the retract speed is greater than 2 to 1.

A gland drain port is provided in the retainer, except in mounting style JJ, style D in 100mm to 200mm bores, and regardless of mounting style, 25mm bore with all rod numbers, and 32mm to 40mm bores with number 1 rod. In these cases the drain port is located in the head. When the gland drain port in 25mm to 40mm bores is in the head of all mounting styles except JJ, it must be in the same position as the port (on the 5mm elongated side for 25mm & 32mm bores) and when specified in 25mm and 32mm bores of mounting style C it must be in position 1. On JJ mounting styles in 25mm and 32mm bores the drain port can be in position 2 or 4 and is not available in position 3. When the gland drain port is provided in the retainer, the thickness of the retainer is increased by 6mm in 32mm and 40mm bores with number 2 rod and by 4mm in 63mm bore cylinders with number 2 rod. Note that, on style JJ cylinders, drain ports cannot normally be positioned in the same face as ports or cushion valves – please consult the factory.

Gland Drain Port Location & Position Availability

Bore Ø	Rod Ø	Head (H) or Retainer (R) Location / Position			
		TB, TC, TD, HH, B, BB, SB, DB, DD	C	D	JJ
25	All	H / 1, 2, 3, 4	H / 1	H / 1, 3	H / 2, 4
32	14	H / 1, 2, 3, 4	H / 1	H / 1, 3	H / 2, 4
	22	R / 1, 2, 3, 4	R / 1, 2, 3 ¹ , 4	R / 1, 2, 3, 4	H / 2, 4
40	18	H / 1, 2, 3, 4	H / 1	H / 1, 3	H / 2, 3, 4
	28	R / 1, 2, 3, 4	R / 1, 2, 3, 4	R / 1, 2, 3, 4	H / 2, 3, 4
50	All	R / 1, 2, 3, 4	R / 1, 2, 3, 4	R / 1, 2, 3, 4	H / 2, 3, 4
63	All	R / 1, 2, 3, 4	R / 1, 2, 3, 4	R / 1, 2, 3, 4	H / 2, 3, 4
80	All	R / 1, 2, 3, 4	R / 1, 2, 3, 4	R / 1, 2, 3, 4	H / 2, 3, 4
100	All	R / 1, 2, 3, 4	R / 1, 2, 3, 4	H / 1, 3	H / 2, 3, 4
125	All	R / 1, 2, 3, 4	R / 1, 2, 3, 4	H / 1, 3	H / 2, 3, 4
160	All	R / 1, 2, 3, 4	R / 1, 2, 3, 4	H / 1, 3	H / 2, 3, 4
200	All	R / 1, 2, 3, 4	R / 1, 2, 3, 4	H / 1, 3	H / 2, 3, 4

¹ Gland drain is not available in position 3 when key plate is specified.

Gland drain ports will be the same type as the ports specified on the cylinder assembly except for non “JJ” mounts on bore sizes 25, 32, 40 and 50 mm. In these cases they will be 1/8 NPTF.

The size of the gland drain ports are as shown on the adjacent table.

Gland drains should be piped back to the fluid reservoir, which should be located below the level of the cylinder.

Port Type	Port Size
R (BSPP)	1/8 BSPP
T (SAE)	#4 (SAE)
U (Pipe Thread)	1/8 NPTF
M (Metric Straight)	M10 x 1
Y (ISO 6149-1)	M10 x 1
B (BSPT)	1/8 BSPT
P (SAE 4 Bolt Flange)	1/8 BSPP

Air Bleeds

The option of bleed screws is available at either or both ends of the cylinder, at any position except in the port face. The selected positions should be shown in the order code. Cylinders with bore sizes up to 40mm are fitted with M5 bleed screws; for bore sizes of 50mm and above, M8 bleed screws are fitted. Note that, for cylinders of 50mm bore and above, where it is essential to have the air bleed in the port face, bosses can be welded to the cylinder tube. Please contact the factory for details.

Spring-Returned, Single-Acting Cylinders

SHM Series single-acting cylinders can be supplied with an internal spring to return the piston after the pressure stroke. Please supply details of load conditions and friction factors, and advise whether the spring is required to advance or return the piston rod.

On spring-returned cylinders, tie rod extensions will be supplied to allow the spring to be ‘backed off’ until compression is relieved. Tie rod nuts will be welded to the tie rods at the opposite end of the cylinder, to further assure safe disassembly. Please contact the factory when ordering spring-returned cylinders.

Duplex and Tandem Cylinders

A tandem cylinder is made up of two cylinders mounted in line with pistons connected by a common piston rod and rod seals installed between the cylinders to permit double acting operation of each. Tandem cylinders allow increased output force when mounting width or height are restricted.

A duplex cylinder is made up of two cylinders mounted in line with pistons not connected with rod seals installed between the cylinders to permit double acting operation of each. Cylinders may be mounted with piston rod to piston or back to back and are generally used to provide three position operation.

Stroke Adjusters

Where absolute precision in stroke length is required, a screwed adjustable stop can be supplied. Several types are available – the illustration shows a design suitable for infrequent² adjustment at the uncushioned cap end of a cylinder. Please contact the factory, specifying details of the application and the adjustment required.

Bore Ø	D	J	K min	L max
40	M12x1.25	7	75	130
50	M20x1.5	12	75	200
63	M27x2	16	75	230
80	M33x2	20	85	230
100	M42x2	26	70	450
125	M48x2	30	70	500
160	M64x3	40	75	500
200	M80x3	50	80	500

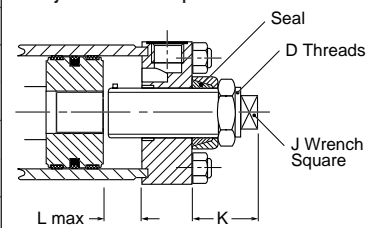

All dimensions are in millimeters unless otherwise stated.

² Infrequent is defined by positioning the retract stroke in a couple of attempts at original machine set up. The frequent stroke adjuster is recommended for adjustments required after the original equipment has been adjusted by the original machine manufacturer.

NOTES

C

NOTES

NOTES

C

Safety Guide for Selecting and Using Hydraulic, Pneumatic Cylinders and Their Accessories

WARNING: ⚠ FAILURE OF THE CYLINDER, ITS PARTS, ITS MOUNTING, ITS CONNECTIONS TO OTHER OBJECTS, OR ITS CONTROLS CAN RESULT IN:

- Unanticipated or uncontrolled movement of the cylinder or objects connected to it.
- Falling of the cylinder or objects held up by it.
- Fluid escaping from the cylinder, potentially at high velocity.

THESE EVENTS COULD CAUSE DEATH OR PERSONAL INJURY BY, FOR EXAMPLE, PERSONS FALLING FROM HIGH LOCATIONS, BEING CRUSHED OR STRUCK BY HEAVY OR FAST MOVING OBJECTS, BEING PUSHED INTO DANGEROUS EQUIPMENT OR SITUATIONS, OR SLIPPING ON ESCAPED FLUID.

Before selecting or using Parker (The Company) cylinders or related accessories, it is important that you read, understand and follow the following safety information. Training is advised before selecting and using The Company's products.

1.0 General Instructions

1.1 Scope – This safety guide provides instructions for selecting and using (including assembling, installing, and maintaining) cylinder products. This safety guide is a supplement to and is to be used with the specific Company publications for the specific cylinder products that are being considered for use.

1.2 Fail Safe – Cylinder products can and do fail without warning for many reasons. All systems and equipment should be designed in a fail-safe mode so that if the failure of a cylinder product occurs people and property won't be endangered.

1.3 Distribution – Provide a free copy of this safety guide to each person responsible for selecting or using cylinder products. Do not select or use The Company's cylinders without thoroughly reading and understanding this safety guide as well as the specific Company publications for the products considered or selected.

1.4 User Responsibility – Due to very wide variety of cylinder applications and cylinder operating conditions, The Company does not warrant that any particular cylinder is suitable for any specific application. This safety guide does not analyze all technical parameters that must be considered in selecting a product. The hydraulic and pneumatic cylinders outlined in this catalog are designed to The Company's design guidelines and do not necessarily meet the design guideline of other agencies such as American Bureau of Shipping, ASME Pressure Vessel Code etc. The user, through its own analysis and testing, is solely responsible for:

- Making the final selection of the cylinders and related accessories.
- Determining if the cylinders are required to meet specific design requirements as required by the Agency(s) or industry standards covering the design of the user's equipment.
- Assuring that the user's requirements are met, OSHA requirements are met, and safety guidelines from the applicable agencies such as but not limited to ANSI are followed and that the use presents no health or safety hazards.
- Providing all appropriate health and safety warnings on the equipment on which the cylinders are used.

1.5 Additional Questions – Call the appropriate Company technical service department if you have any questions or require any additional information. See the Company publication for the product being considered or used, or call 1-847-298-2400, or go to www.parker.com, for telephone numbers of the appropriate technical service department.

2.0 Cylinder and Accessories Selection

2.1 Seals – Part of the process of selecting a cylinder is the selection of seal compounds. Before making this selection, consult the "seal information page(s)" of the publication for the series of cylinders of interest.

The application of cylinders may allow fluids such as cutting fluids, wash down fluids etc. to come in contact with the external area of the cylinder. These fluids may attack the piston rod wiper and or the primary seal and must be taken into account when selecting and specifying seal compounds.

Dynamic seals will wear. The rate of wear will depend on many operating factors. Wear can be rapid if a cylinder is mis-aligned or if the cylinder has been improperly serviced. The user must take seal wear into consideration in the application of cylinders.

2.2 Piston Rods – Possible consequences of piston rod failure or separation of the piston rod from the piston include, but are not limited to are:

- Piston rod and or attached load thrown off at high speed.
- High velocity fluid discharge.
- Piston rod extending when pressure is applied in the piston retract mode.

Piston rods or machine members attached to the piston rod may move suddenly and without warning as a consequence of other conditions occurring to the machine such as, but not limited to:

- Unexpected detachment of the machine member from the piston rod.

- Failure of the pressurized fluid delivery system (hoses, fittings, valves, pumps, compressors) which maintain cylinder position.
- Catastrophic cylinder seal failure leading to sudden loss of pressurized fluid.
- Failure of the machine control system.

Follow the recommendations of the "Piston Rod Selection Chart and Data" in the publication for the series of cylinders of interest. The suggested piston rod diameter in these charts must be followed in order to avoid piston rod buckling.

Piston rods are not normally designed to absorb bending moments or loads which are perpendicular to the axis of piston rod motion. These additional loads can cause the piston rod to fail. If these types of additional loads are expected to be imposed on the piston rod, their magnitude should be made known to our engineering department.

The cylinder user should always make sure that the piston rod is securely attached to the machine member.

On occasion cylinders are ordered with double rods (a piston rod extended from both ends of the cylinder). In some cases a stop is threaded on to one of the piston rods and used as an external stroke adjuster. On occasions spacers are attached to the machine member connected to the piston rod and also used as a stroke adjuster. In both cases the stops will create a pinch point and the user should consider appropriate use of guards. If these external stops are not perpendicular to the mating contact surface, or if debris is trapped between the contact surfaces, a bending moment will be placed on the piston rod, which can lead to piston rod failure. An external stop will also negate the effect of cushioning and will subject the piston rod to impact loading. Those two (2) conditions can cause piston rod failure. Internal stroke adjusters are available with and without cushions. The use of external stroke adjusters should be reviewed with our engineering department.

The piston rod to piston and the stud to piston rod threaded connections are secured with an anaerobic adhesive. The strength of the adhesive decreases with increasing temperature. Cylinders which can be exposed to temperatures above +250°F (+121°C) are to be ordered with a non studded piston rod and a pinned piston to rod joint.

2.3 Cushions – Cushions should be considered for cylinder applications when the piston velocity is expected to be over 4 inches/second.

Cylinder cushions are normally designed to absorb the energy of a linear applied load. A rotating mass has considerably more energy than the same mass moving in a linear mode. Cushioning for a rotating mass application should be reviewed by our engineering department.

2.4 Cylinder Mountings – Some cylinder mounting configurations may have certain limitations such as but not limited to minimum stroke for side or foot mounting cylinders or pressure de-ratings for certain mounts. Carefully review the catalog for these types of restrictions.

Always mount cylinders using the largest possible high tensile alloy steel socket head cap screws that can fit in the cylinder mounting holes and torque them to the manufacturer's recommendations for their size.

2.5 Port Fittings – Hydraulic cylinders applied with meter out or deceleration circuits are subject to intensified pressure at piston rod end.

The rod end pressure is approximately equal to:

$$\frac{\text{operating pressure} \times \text{effective cap end area}}{\text{effective rod end piston area}}$$

Contact your connector supplier for the pressure rating of individual connectors.

3.0 Cylinder and Accessories Installation and Mounting

3.1 Installation

3.1.1 – Cleanliness is an important consideration, and cylinders are shipped with the ports plugged to protect them from contaminants entering the ports. These plugs should not be removed until the piping is to be installed. Before making the connection to the cylinder ports, piping should be thoroughly cleaned to remove all chips or burrs which might have resulted from threading or flaring operations.

3.1.2 – Cylinders operating in an environment where air drying materials are present such as fast-drying chemicals, paint, or weld splatter, or other hazardous conditions such as excessive heat, should have shields installed to prevent damage to the piston rod and piston rod seals.

3.1.3 – Proper alignment of the cylinder piston rod and its mating component on the machine should be checked in both the extended and retracted positions. Improper alignment will result in excessive rod gland and/or cylinder bore wear. On fixed mounting cylinders attaching the piston rod while the rod is retracted will help in achieving proper alignment.

3.1.4 – Sometimes it may be necessary to rotate the piston rod in order to thread the piston rod into the machine member. This operation must always be done with zero pressure being applied to either side of the piston. Failure to follow this procedure may result in loosening the piston to rod-threaded connection. In some rare cases the turning of the piston rod may rotate a threaded piston rod gland and loosen it from the cylinder head. Confirm that this condition is not occurring. If it does, re-tighten the piston rod gland firmly against the cylinder head.

For double rod cylinders it is also important that when attaching or detaching the piston rod from the machine member that the torque be applied to the piston rod end of the cylinder that is directly attaching to the machine member with the opposite end unrestrained. If the design of the machine is such that only the rod end of the cylinder opposite to where the rod attaches to the machine member can be rotated, consult the factory for further instructions.

3.2 Mounting Recommendations

3.2.1 – Always mount cylinders using the largest possible high tensile alloy steel socket head screws that can fit in the cylinder mounting holes and torque them to the manufacturer's recommendations for their size.

3.2.2 – Side-Mounted Cylinders – In addition to the mounting bolts, cylinders of this type should be equipped with thrust keys or dowel pins located so as to resist the major load.

3.2.3 – Tie Rod Mounting – Cylinders with tie rod mountings are recommended for applications where mounting space is limited. The standard tie rod extension is shown as BB in dimension tables. Longer or shorter extensions can be supplied. Nuts used for this mounting style should be torqued to the same value as the tie rods for that bore size.

3.2.4 – Flange Mount Cylinders – The controlled diameter of the rod gland extension on head end flange mount cylinders can be used as a pilot to locate the cylinders in relation to the machine. After alignment has been obtained, the flanges may be drilled for pins or dowels to prevent shifting.

3.2.5 – Trunnion Mountings – Cylinders require lubricated bearing blocks with minimum bearing clearances. Bearing blocks should be carefully aligned and rigidly mounted so the trunnions will not be subjected to bending moments. The rod end should also be pivoted with the pivot pin in line and parallel to axis of the trunnion pins.

3.2.6 – Clevis Mountings – Cylinders should be pivoted at both ends with centerline of pins parallel to each other. After cylinder is mounted, be sure to check to assure that the cylinder is free to swing through its working arc without interference from other machine parts.

4.0 Cylinder and Accessories Maintenance, Troubleshooting and Replacement

4.1 Storage – At times cylinders are delivered before a customer is ready to install them and must be stored for a period of time. When storage is required the following procedures are recommended.

4.1.1 – Store the cylinders in an indoor area which has a dry, clean and noncorrosive atmosphere. Take care to protect the cylinder from both internal corrosion and external damage.

4.1.2 – Whenever possible cylinders should be stored in a vertical position (piston rod up). This will minimize corrosion due to possible condensation which could occur inside the cylinder. This will also minimize seal damage.

4.1.3 – Port protector plugs should be left in the cylinder until the time of installation.

4.1.4 – If a cylinder is stored full of hydraulic fluid, expansion of the fluid due to temperature changes must be considered. Installing a check valve with free flow out of the cylinder is one method.

4.1.5 – When cylinders are mounted on equipment that is stored outside for extended periods, exposed unpainted surfaces, e.g. piston rod, must be coated with a rust-inhibiting compound to prevent corrosion.

4.2 Cylinder Trouble Shooting

4.2.1 – External Leakage

4.2.1.1 – Rod seal leakage can generally be traced to worn or damaged seals. Examine the piston rod for dents, gouges or score marks, and replace piston rod if surface is rough.

Rod seal leakage could also be traced to gland wear. If clearance is excessive, replace rod bushing and seal. Rod seal leakage can also be traced to seal deterioration. If seals are soft or gummy or brittle, check compatibility of seal material with lubricant used if air cylinder, or operating fluid if hydraulic cylinder. Replace with seal material, which is compatible with these fluids. If the seals are hard or have lost elasticity, it is usually due to exposure to temperatures in excess of 165°F. (+74°C). Shield the cylinder from the heat source to limit temperature to 350°F. (+177°C.) and replace with fluorocarbon seals.

4.2.1.2 – Cylinder body seal leak can generally be traced to loose tie rods. Torque the tie rods to manufacturer's recommendation for that bore size.

Excessive pressure can also result in cylinder body seal leak. Determine maximum pressure to rated limits. Replace seals and retorque tie rods as in paragraph above. Excessive pressure can also result in cylinder body seal leak. Determine if the pressure rating of the cylinder has been exceeded. If so, bring the operating pressure down to the rating of the cylinder and have the tie rods replaced.

Pinched or extruded cylinder body seal will also result in a leak. Replace cylinder body seal and retorque as in paragraph above.

Cylinder body seal leakage due to loss of radial squeeze which shows up in the form of flat spots or due to wear on the O.D. or I.D. – Either of these are symptoms of normal wear due to high cycle rate or length of service. Replace seals as per paragraph above.

4.2.2 – Internal Leakage

4.2.2.1 – Piston seal leak (by-pass) 1 to 3 cubic inches per minute leakage is considered normal for piston ring construction. Virtually no static leak with lipseal type seals on piston should be expected. Piston seal wear is a usual cause of piston seal leakage. Replace seals as required.

4.2.2.2 – With lipseal type piston seals excessive back pressure due to over-adjustment of speed control valves could be a direct cause of rapid seal wear. Contamination in a hydraulic system can result in a scored cylinder bore, resulting in rapid seal wear. In either case, replace piston seals as required.

4.2.2.3 – What appears to be piston seal leak, evidenced by the fact that the cylinder drifts, is not always traceable to the piston. To make sure, it is suggested that one side of the cylinder piston be pressurized and the fluid line at the opposite port be disconnected. Observe leakage. If none is evident, seek the cause of cylinder drift in other component parts in the circuit.

4.2.3 – Cylinder Fails to Move the Load

4.2.3.1 – Pneumatic or hydraulic pressure is too low. Check the pressure at the cylinder to make sure it is to circuit requirements.

4.2.3.2 – Piston Seal Leak – Operate the valve to cycle the cylinder and observe fluid flow at valve exhaust ports at end of cylinder stroke. Replace piston seals if flow is excessive.

4.2.3.3 – Cylinder is undersized for the load – Replace cylinder with one of a larger bore size.

4.3 Erratic or Chatter Operation

4.3.1 – Excessive friction at rod gland or piston bearing due to load misalignment – Correct cylinder-to-load alignment.

4.3.2 – Cylinder sized too close to load requirements – Reduce load or install larger cylinder.

4.3.3 – Erratic operation could be traced to the difference between static and kinetic friction. Install speed control valves to provide a back pressure to control the stroke.

4.4 Cylinder Modifications, Repairs, or Failed Component – Cylinders as shipped from the factory are not to be disassembled and or modified. If cylinders require modifications, these modifications must be done at company locations or by The Company's certified facilities. The Industrial Cylinder Division Engineering Department must be notified in the event of a mechanical fracture or permanent deformation of any cylinder component (excluding seals). This includes a broken piston rod, tie rod, mounting accessory or any other cylinder component. The notification should include all operation and application details. This information will be used to provide an engineered repair that will prevent recurrence of the failure.

It is allowed to disassemble cylinders for the purpose of replacing seals or seal assemblies. However, this work must be done by strictly following all the instructions provided with the seal kits.

Notes

NOTES

Offer of Sale

The items described in this document and other documents and descriptions provided by Parker Hannifin Corporation, Hydraulics Group, and its authorized distributors ("Seller") are hereby offered for sale at prices to be established by Seller. This offer and its acceptance by any customer ("Buyer") shall be governed by all of the following Terms and Conditions. Buyer's order for any item described in its document, when communicated to Seller verbally, or in writing, shall constitute acceptance of this offer. All goods or work described will be referred to as "Products".

1. Terms and Conditions. Seller's willingness to offer Products, or accept an order for Products, to or from Buyer is expressly conditioned on Buyer's assent to these Terms and Conditions and to the terms and conditions found on-line at www.parker.com/saleterms/. Seller objects to any contrary or additional term or condition of Buyer's order or any other document issued by Buyer.

2. Price Adjustments; Payments. Prices stated on the reverse side or preceding pages of this document are valid for 30 days. After 30 days, Seller may change prices to reflect any increase in its costs resulting from state, federal or local legislation, price increases from its suppliers, or any change in the rate, charge, or classification of any carrier. The prices stated on the reverse or preceding pages of this document do not include any sales, use, or other taxes unless so stated specifically. Unless otherwise specified by Seller, all prices are F.O.B. Seller's facility, and payment is due 30 days from the date of invoice. After 30 days, Buyer shall pay interest on any unpaid invoices at the rate of 1.5% per month or the maximum allowable rate under applicable law.

3. Delivery Dates; Title and Risk; Shipment. All delivery dates are approximate and Seller shall not be responsible for any damages resulting from any delay. Regardless of the manner of shipment, title to any products and risk of loss or damage shall pass to Buyer upon tender to the carrier at Seller's facility (i.e., when it's on the truck, it's yours). Unless otherwise stated, Seller may exercise its judgment in choosing the carrier and means of delivery. No deferment of shipment at Buyers' request beyond the respective dates indicated will be made except on terms that will indemnify, defend and hold Seller harmless against all loss and additional expense. Buyer shall be responsible for any additional shipping charges incurred by Seller due to Buyer's changes in shipping, product specifications or in accordance with Section 13, herein.

4. Warranty. Seller warrants that the Products sold hereunder shall be free from defects in material or workmanship for a period of eighteen months from the date of delivery to Buyer. The prices charged for Seller's products are based upon the exclusive limited warranty stated above, and upon the following disclaimer: **DISCLAIMER OF WARRANTY: THIS WARRANTY COMPRISES THE SOLE AND ENTIRE WARRANTY PERTAINING TO PRODUCTS PROVIDED HEREUNDER. SELLER DISCLAIMS ALL OTHER WARRANTIES, EXPRESS AND IMPLIED, INCLUDING MERCHANTABILITY AND FITNESS FOR A PARTICULAR PURPOSE.**

5. Claims; Commencement of Actions. Buyer shall promptly inspect all Products upon delivery. No claims for shortages will be allowed unless reported to the Seller within 10 days of delivery. No other claims against Seller will be allowed unless asserted in writing within 60 days after delivery or, in the case of an alleged breach of warranty, within 30 days after the date within the warranty period on which the defect is or should have been discovered by Buyer. Any action based upon breach of this agreement or upon any other claim arising out of this sale (other than an action by Seller for any amount due to Seller from Buyer) must be commenced within thirteen months from the date of tender of delivery by Seller or, for a cause of action based upon an alleged breach of warranty, within thirteen months from the date within the warranty period on which the defect is or should have been discovered by Buyer.

6. LIMITATION OF LIABILITY. UPON NOTIFICATION, SELLER WILL, AT ITS OPTION, REPAIR OR REPLACE A DEFECTIVE PRODUCT, OR REFUND THE PURCHASE PRICE. IN NO EVENT SHALL SELLER BE LIABLE TO BUYER FOR ANY SPECIAL, INDIRECT, INCIDENTAL OR CONSEQUENTIAL DAMAGES ARISING OUT OF, OR AS THE RESULT OF, THE SALE, DELIVERY, NON-DELIVERY, SERVICING, USE OR LOSS OF USE OF THE PRODUCTS OR ANY PART THEREOF, OR FOR ANY CHARGES OR EXPENSES OF ANY NATURE INCURRED WITHOUT SELLER'S WRITTEN CONSENT, EVEN IF SELLER HAS BEEN NEGLIGENT, WHETHER IN CONTRACT, TORT OR OTHER LEGAL THEORY. IN NO EVENT SHALL SELLER'S LIABILITY UNDER ANY CLAIM MADE BY BUYER EXCEED THE PURCHASE PRICE OF THE PRODUCTS.

7. Contingencies. Seller shall not be liable for any default or delay in performance if caused by circumstances beyond the reasonable control of Seller.

8. User Responsibility. The user, through its own analysis and testing, is solely responsible for making the final selection of the system and Product and assuring that all performance, endurance, maintenance, safety and warning requirements of the application are met. The user must analyze all aspects of the application and follow applicable industry standards and Product information. If Seller provides Product or system options, the user is responsible for determining that such data and specifications are suitable and sufficient for all applications and reasonably foreseeable uses of the Products or systems.

9. Loss to Buyer's Property. Any designs, tools, patterns, materials, drawings, confidential information or equipment furnished by Buyer or any other items which become Buyer's property, may be considered obsolete and may be destroyed by Seller after two consecutive years have elapsed without Buyer placing an order for the items which are manufactured using such property. Seller shall not be responsible for any loss or damage to such property while it is in Seller's possession or control.

10. Special Tooling. A tooling charge may be imposed for any special tooling, including without limitation, dies, fixtures, molds and patterns, acquired to manufacture Products. Such special tooling shall be and remain Seller's property notwithstanding payment of any charges by Buyer. In no event will Buyer acquire any interest in apparatus belonging to Seller which is utilized in the manufacture of the Products, even if such apparatus has been specially converted or adapted for such manufacture and notwithstanding any charges paid by Buyer. Unless otherwise agreed, Seller shall have the right to alter, discard or otherwise dispose of any special tooling or other property in its sole discretion at any time.

11. Buyer's Obligation; Rights of Seller. To secure payment of all sums due or otherwise, Seller shall retain a security interest in the goods delivered and this agreement shall be deemed a Security Agreement under the Uniform Commercial Code. Buyer authorizes Seller as its attorney to execute and file on Buyer's behalf all documents Seller deems necessary to perfect its security interest. Seller shall have a security interest in, and lien upon, any property of Buyer in Seller's possession as security for the payment of any amounts owed to Seller by Buyer.

12. Improper Use and Indemnity. Buyer shall indemnify, defend, and hold Seller harmless from any claim, liability, damages, lawsuits, and costs (including attorney fees), whether for personal injury, property damage, patent, trademark or copyright infringement or any other claim, brought by or incurred by Buyer, Buyer's employees, or any other person, arising out of: (a) improper selection, improper application or other misuse of Products purchased by Buyer from Seller; (b) any act or omission, negligent or otherwise, of Buyer; (c) Seller's use of patterns, plans, drawings, or specifications furnished by Buyer to manufacture Product; or (d) Buyer's failure to comply with these terms and conditions. Seller shall not indemnify Buyer under any circumstance except as otherwise provided.

13. Cancellations and Changes. Orders shall not be subject to cancellation or change by Buyer for any reason, except with Seller's written consent and upon terms that will indemnify, defend and hold Seller harmless against all direct, incidental and consequential loss or damage. Seller may change product features, specifications, designs and availability with notice to Buyer.

14. Limitation on Assignment. Buyer may not assign its rights or obligations under this agreement without the prior written consent of Seller.

15. Entire Agreement. This agreement contains the entire agreement between the Buyer and Seller and constitutes the final, complete and exclusive expression of the terms of the agreement. All prior or contemporaneous written or oral agreements or negotiations with respect to the subject matter are herein merged.

16. Waiver and Severability. Failure to enforce any provision of this agreement will not waive that provision nor will any such failure prejudice Seller's right to enforce that provision in the future. Invalidation of any provision of this agreement by legislation or other rule of law shall not invalidate any other provision herein. The remaining provisions of this agreement will remain in full force and effect.

17. Termination. This agreement may be terminated by Seller for any reason and at any time by giving Buyer thirty (30) days written notice of termination. In addition, Seller may by written notice immediately terminate this agreement for the following: (a) Buyer commits a breach of any provision of this agreement (b) the appointment of a trustee, receiver or custodian for all or any part of Buyer's property (c) the filing of a petition for relief in bankruptcy of the other Party on its own behalf, or by a third party (d) an assignment for the benefit of creditors, or (e) the dissolution or liquidation of the Buyer.

18. Governing Law. This agreement and the sale and delivery of all Products hereunder shall be deemed to have taken place in and shall be governed and construed in accordance with the laws of the State of Ohio, as applicable to contracts executed and wholly performed therein and without regard to conflicts of laws principles. Buyer irrevocably agrees and consents to the exclusive jurisdiction and venue of the courts of Cuyahoga County, Ohio with respect to any dispute, controversy or claim arising out of or relating to this agreement. Disputes between the parties shall not be settled by arbitration unless, after a dispute has arisen, both parties expressly agree in writing to arbitrate the dispute.

19. Indemnity for Infringement of Intellectual Property Rights. Seller shall have no liability for infringement of any patents, trademarks, copyrights, trade dress, trade secrets or similar rights except as provided in this Section. Seller will defend and indemnify Buyer against allegations of infringement of U.S. patents, U.S. trademarks, copyrights, trade dress and trade secrets ("Intellectual Property Rights"). Seller will defend at its expense and will pay the cost of any settlement or damages awarded in an action brought against Buyer based on an allegation that a Product sold pursuant to this Agreement infringes the Intellectual Property Rights of a third party. Seller's obligation to defend and indemnify Buyer is contingent on Buyer notifying Seller within ten (10) days after Buyer becomes aware of such allegations of infringement, and Seller having sole control over the defense of any allegations or actions including all negotiations for settlement or compromise. If a Product is subject to a claim that it infringes the Intellectual Property Rights of a third party, Seller may, at its sole expense and option, procure for Buyer the right to continue using the Product, replace or modify the Product so as to make it noninfringing, or offer to accept return of the Product and return the purchase price less a reasonable allowance for depreciation. Notwithstanding the foregoing, Seller shall have no liability for claims of infringement based on information provided by Buyer, or directed to Products delivered hereunder for which the designs are specified in whole or part by Buyer, or infringements resulting from the modification, combination or use in a system of any Product sold hereunder. The foregoing provisions of this Section shall constitute Seller's sole and exclusive liability and Buyer's sole and exclusive remedy for infringement of Intellectual Property Rights.

20. Taxes. Unless otherwise indicated, all prices and charges are exclusive of excise, sales, use, property, occupational or like taxes which may be imposed by any taxing authority upon the manufacture, sale or delivery of Products.

21. Equal Opportunity Clause. For the performance of government contracts and where dollar value of the Products exceed \$10,000, the equal employment opportunity clauses in Executive Order 11246, VEVRRA, and 41 C.F.R. §§ 60-1.4(a), 60-741 5(a), and 60-250.4, are hereby incorporated.

Parker Hannifin Corporation
Schrader Bellows
Industrial Cylinder Division
500 South Wolf Road
Des Plaines, IL 60016 USA
phone (847) 298-2400
fax (800) 892-1008
www.schraderbellows.com

